

VARI***LITE**

VLZ WASH Luminaire



USER'S MANUAL

Version as of: 10 January 2017
Part number: 02.9708.0001

VLZ WASH Luminaire User's Manual
©2013 Vari-Lite. All Rights Reserved.

How To Obtain Warranty Service

A copy of the Vari-Lite Limited Warranty was included in the shipping package for this VARI***LITE** product.

To obtain warranty service, please contact customer service at 1-877-VARI-LITE (1-877-827-4548), +1-214-647-7880, or entertainment.service@philips.com and request a Return Material Authorization (RMA) for warranty service. You will need to provide the model and serial number of the item being returned, a description of the problem or failure and the name of the registered user or organization. If available, you should have your sales invoice to establish the date of sale as the beginning of the warranty period.

Once you obtain the RMA, pack the unit in a secure shipping container or in its original packing box. Be sure to clearly indicate the RMA number on all packing lists, correspondence, and shipping labels. If available, please include a copy of your invoice (as proof of purchase) in the shipping container. With the RMA number written legibly on or near the shipping address label, return the unit, freight prepaid, to:

Vari-Lite
 Attention: Warranty Service (RMA# _____)
 10911 Petal Street
 Dallas Dallas, Texas 75238 USA
 Attention: Warranty Service

As stated in the warranty, it is required that the shipment be insured and FOB our service center.



IMPORTANT! When returning products to Vari-Lite for repairs (warranty or out-of-warranty) from a country other than the USA, “**Philips Lighting Controls Division**”, must appear in the address block as the Importer of Record (IOR) on all shipping documentation, Commercial Invoices, etc. This must be done in order to clear customs in a timely manner and prevent returns.

Compliance Notices

FCC This equipment has been tested and found to comply with the limits for a Class A digital device pursuant to Part 15 of FCC Rules. These limits are designed to provide reasonable protection against harmful interference when this equipment is operated in a commercial environment. This equipment generates, uses, and can radiate radio frequency energy and, if not installed and used in accordance with Vari-Lite system, service, and safety guidelines, may cause harmful interference to radio communications. Operation of this equipment in a residential area is likely to cause harmful interference, in which case the user will be required to correct the interference at his/her own expense.

CE Declaration of Conformity

We declare, under our sole responsibility, that this product complies with the relevant clauses of the following standards and harmonized documents:

Safety

EN 60598-1:2015; EN 60598-2-17:1989+A2:1991;EN 62493:2015;EN 62031:2008+A1:2013+A2:2015;EN 62471:2008;Low Voltage Directive 2014/35/EU

EMC

EN 55015:2013
EN 61000-3-2:2014
EN 61000-3-3:2013
EN 61547:2009
EMC Directive 2014/30/EU
Same as Legal Entity

RoHS

EN 62321:2012

We certify that the product conforms to the protection requirements of council directives: Low Voltage Directive 2014/35/EU, 2014/30/EU (EMC), and Restriction of the use of certain Hazardous Substances in electrical and electronic equipment Directive (RoHS), 2015/863. Equipment referred to in this declaration of conformity was first manufactured in 2017 in compliance with these standards.

Safety Notices

It is extremely important to read ALL safety information and instructions provided in this manual and any accompanying documentation before installing and operating the products described herein. Heed all cautions and warnings during installation and use of this product.

Safety symbols used throughout this manual are as follows:



CAUTION advising of potential damage to product.



WARNING advising of potential injury or death to persons.

GENERAL INFORMATION PERTAINING TO PROTECTION AGAINST ELECTRICAL SHOCK, FIRE, EXPOSURE TO EXCESSIVE UV RADIATION, AND INJURY TO PERSONS CAN BE FOUND BELOW.

WARNING:

INSTRUCTIONS FOR CONTINUED PROTECTION AGAINST FIRE

- 1 Luminaires may be mounted on any type of surface as long as mounting instructions are followed. See instructions detailed in this manual.
- 2 Note distance requirement from combustible materials or illuminated objects for VARI*LITE luminaires.

WARNING:

INSTRUCTIONS FOR CONTINUED PROTECTION AGAINST ELECTRICAL SHOCK

- 1 VARI*LITE luminaires are designed for dry locations only. Exposure to rain or moisture may damage luminaire.
- 2 Disconnect power before servicing any VARI*LITE equipment.
- 3 Servicing to be performed by qualified personnel only.

WARNING:

INSTRUCTIONS FOR CONTINUED PROTECTION AGAINST EXCESSIVE EXPOSURE TO UV RADIATION

1. Many VARI***LITE** luminaires use LED that produces UV radiation. **DO NOT** look directly at LED.
2. It is hazardous to operate luminaires without lens or shield. Shields, lenses, or ultraviolet screens shall be changed if they have become visibly damaged to such an extent that their effectiveness is impaired. For example, by cracks or deep scratches.

WARNING: INSTRUCTIONS FOR PROTECTION AGAINST INJURY TO PERSONS

1. Exterior surfaces of the luminaire will be hot during operation. Use appropriate safety equipment (gloves, eye protection, etc.) when handling and adjusting hot equipment and components.
2. Luminaires will have a hot LED when operating. Disconnect power and allow LED to cool before replacing.
3. LED emit ultraviolet radiation which can cause serious skin burn and eye inflammation. Additionally, LED operate under high pressure at very high temperatures. Should the LED break, there can exist a danger of personal injury and/or fire from broken LED particles being discharged.
4. Wear eye protection when relamping.
5. Appropriate safety equipment (gloves, eye protection) should be used when handling damaged LED.
6. If LED is touched with bare hands, clean LED with denatured alcohol and wipe with lint-free cloth before installing or powering up the luminaire.
7. The LED shall be changed if it has become damaged or thermally deformed.

WARNING: RF INTERFERENCE

1. This is a Class A product. In a domestic environment this product may cause radio interference, in which case, the user may be required to take adequate measures.

LED CHARACTERISTIC CONSIDERATIONS

1. LED require a period of time to relight after a power interruption or a severe voltage dip. In some cases, LED will automatically relight after it has cooled depending on Power-Up State configuration setting.
2. Burning position is Universal.

Sicherheitshinweise

Es ist äußerst wichtig, ALLE Sicherheitsinformationen und -hinweise in diesem Handbuch und dem beiliegenden Informationsmaterial zu lesen, bevor Sie die hierin beschriebenen Produkte installieren bzw. bedienen. Halten Sie bei der Installation und dem Einsatz dieses Produkts alle Warnhinweise und Vorsichtsmaßnahmen ein.

Folgende Sicherheitssymbole werden in diesem Handbuch verwendet:



VORSICHT - weist auf möglichen Produktschaden hin.



WARNUNG - weist auf mögliche Körperverletzung und Lebensbedrohung hin.

NACHSTEHEND FINDEN SIE ALLGEMEINE HINWEISE ÜBER SICHERHEITSVORKEHRUNGEN GEGEN ELEKTROSCHOCK, FEUER, ÜBERHÖHTE UVSTRAHLUNG UND KÖRPERVERLETZUNGEN.

WARNUNG: HINWEISE ZUM FEUERSCHUTZ

1. VARI***LITE** -Scheinwerfer sind ausschließlich für den Einsatz mit bestimmten Lampentyps. Achten Sie auf den Lampentyp (620 Watt LED), bevor Sie die jeweiligen Lampen ersetzen. Die Installation eines anderen Lampentyps kann gefährlich sein.
2. Scheinwerfer können auf jeder beliebigen Oberfläche montiert werden, solange Sie die Montageanweisungen befolgen. Detaillierte Hinweise finden Sie in diesem Handbuch.
3. Beachten Sie die Einhaltung des erforderlichen Sicherheitsabstandes der VARI***LITE** -Scheinwerfer von brennbarem Material oder beleuchteten Objekten.

WARNUNG: HINWEISE ZUM SCHUTZ GEGEN ELEKTROSCHOCK

1. VARI***LITE** -Scheinwerfer eignen sich ausschließlich für trockene Standorte. Regen oder Feuchtigkeit können die Scheinwerfer beschädigen.
2. Unterbrechen Sie die Stromzufuhr, bevor Sie mit der Arbeit an VARI***LITE** -Geräten beginnen.
3. Die Geräte sollten nur von qualifiziertem Personal gewartet werden.

WARNING:

HINWEISE ZUM SCHUTZ GEGEN ÜBERHÖHTE UV-STRAHLUNG

1. Viele VARI*LITE -Scheinwerfer verwenden die Lampentyp, der UV-Strahlen abgibt. SCHAUEN SIE NICHT direkt in die Lampe.
2. Es ist gefährlich, Leuchten ohne Linsen oder Blenden zu bedienen. Blenden, Linsen oder Ultraviolettsschirme müssen ausgetauscht werden, sofern deren Schutzwirkung durch sichtbare Beschädigung (z. B. Sprünge oder Schrammen) eingeschränkt ist.

WARNING:

HINWEISE ZUM SCHUTZ GEGEN KÖRPERVERLETZUNGEN

1. Bei Betrieb sind die Außenflächen der Scheinwerfer heiß. Verwenden Sie bei der Bedienung von aufgeheizter Apparatur die jeweils geeignete Sicherheitsausrüstung (Handschuhe, Augenschutz etc.).
2. Bei Betrieb der Scheinwerfer ist die Lampe heiß. Unterbrechen Sie die Stromzufuhr und lassen Sie die Lampe abkühlen, wenn Sie diese austauschen.
3. Bogenlampen senden ultraviolette Strahlen aus, die Hautverbrennungen und Augenentzündungen verursachen können. Der Betrieb von Bogenlampen erfolgt unter Hochdruck und bei hohen Temperaturen. Sollte die Lampe zerbrechen, besteht die Gefahr von Körperverletzung bzw. von Feuer, das von Lampen eilen ausgelöst werden kann.
4. Tragen Sie beim Austausch der Lampen einen Augenschutz.
5. Die geeignete Sicherheitsausrüstung (Handschuhe, Augenschutz) sollte beim Umgang mit beschädigten Lampen verwendet werden.
6. Wenn die Lampe mit bloßen Händen berührt wird, reinigen Sie sie mit denaturiertem Alkohol und einem flusenfreien Tuch bevor Sie die Scheinwerfer installieren oder in Betrieb nehmen.
7. Wenn die Lampe beschädigt oder durch Hitze einwirkung deformiert ist, muß diese ausgetauscht werden.

WARNING:

HF-INTERFERENZ

1. Es handelt sich um ein Produkt der Klasse A. In einer Wohnumgebung kann das Produkt Hochfrequenzstörungen verursachen. In diesem Fall müssen eventuell geeignete Maßnahmen getroffen werden.

BESONDERHEITEN VON BOGENLAMPEN

1. Bogenlampen benötigen eine gewisse Zeitdauer, um nach einem Stromausfall oder einem Spannungsgefälle wieder aufzuleuchten. In einigen Fällen wird die Lampe nach Abkühlung automatisch wieder aufleuchten, je nach der Systemkonfigurationseinstellung des Lampeneinschaltungsstatus.
2. Die Brennposition ist Universal.

Notes de sécurité

Avant de procéder à l'installation des produits décrits dans ce guide et de les mettre en marche, il est extrêmement important de lire TOUS les renseignements et TOUTES les directives de sécurité contenues dans ce guide ainsi que toute documentation jointe. Tenir compte de tous les avertissements et suivre toutes les précautions pendant l'installation et l'utilisation de cet appareil.

Les symboles de sécurité utilisés dans ce guide sont les suivants :



ATTENTION Ce symbole annonce que l'appareil risque d'être endommagé.



AVERTISSEMENT Ce symbole annonce qu'il y a risque d'accident grave ou même fatal.

CETTE SECTION CONTIENT DES INFORMATIONS GÉNÉRALES POUR SE PROTÉGER CONTRE LES DÉCHARGES ÉLECTRIQUES, LES INCENDIES, L'EXPOSITION EXCESSIVE AUX RAYONS UV ET TOUT AUTRE ACCIDENT POUVANT ENTRAÎNER DES BLESSURES

AVERTISSEMENT:

DIRECTIVES POUR SE PROTÉGER CONTRE LES INCENDIES

1. Les luminaires VARI***LITE** ont été conçus pour être utilisés uniquement avec certains type de lampes. Vérifier le type de lampe (620 Watt LED) avant de remplacer les lampes. L'installation d'un autre type de lampe peut poser un danger.
2. Les luminaires peuvent être fixés sur tout type de surface tant que les directives de montage sont respectées. Voir les explications détaillées dans ce guide.
3. Vérifier l'écartance à respecter entre les matériaux combustibles ou les objets illuminés et les luminaires VARI***LITE**.

AVERTISSEMENT:

DIRECTIVES POUR SE PROTÉGER CONTRE LES DÉCHARGES ÉLECTRIQUES

1. Les luminaires VARI***LITE** sont conçus pour une utilisation au sec uniquement. Une exposition à la pluie et à l'humidité risque d'endommager le luminaire.
2. Débrancher l'appareil avant de procéder à la révision de tout matériel VARI***LITE**.
3. Les révisions doivent être effectuées uniquement par des personnes qualifiées.

AVERTISSEMENT:

DIRECTIVES POUR SE PROTÉGER CONTRE UNE EXPOSITION EXCESSIVE AUX RAYONS UV

1. Plusieurs luminaires VARI*LITE utilisent une lampe qui produit des rayons UV. NE PAS fixer son regard sur la lampe.
2. L'utilisation des luminaires sans lentille ou blindage pose des risques. Tous blindages, lentilles ou écrans ultraviolet visiblement endommagés au point que leur efficacité en est affectée doivent être remplacés, par exemple s'il y a des fissures ou de profondes rayures.

AVERTISSEMENT:

DIRECTIVES POUR SE PROTÉGER CONTRE LES ACCIDENTS POUVANT ENTRAÎNER DES BLESSURES

1. Les surfaces externes du luminaire deviennent brûlantes quand l'appareil est en marche. Pour manœuvrer ou ajuster des appareils brûlants et leurs composants, se protéger suffisamment (gants, protection pour les yeux, etc.).
2. La lampe du luminaire est brûlante lorsqu'il est en marche. Débrancher le courant et attendre que la lampe ait refroidi avant de la remplacer.
3. Les lampes à arc émettent des rayons ultraviolets pouvant causer de graves brûlures sur la peau et une inflammation des yeux. De plus, les lampes à arc fonctionnent sous haute tension à de très hautes températures. Si la lampe se casse, les particules de la lampe cassée peuvent causer blessures et/ou incendie en s'éparpillant.
4. Se protéger les yeux pour remplacer la lampe.
5. Utiliser des appareils de protection appropriés (gants, protection des yeux) pour manier des lampes endommagées.
6. Si la lampe a été touchée avec des mains nues, la nettoyer avec de l'alcool dénaturé et l'essuyer avec un chiffon non-pelucheux avant d'installer ou de brancher le luminaire.
7. Si la lampe a été endommagée ou a reçu une déformation thermique, elle doit être remplacée.

AVERTISSEMENT

INTERFÉRENCE

RF

1. Cet appareil est de Classe A. Dans un environnement domestique, cet appareil peut causer des interférences radio, et si c'est le cas, l'utilisateur peut avoir à prendre des mesures adéquates.

CONSIDÉRATIONS DES CARACTÉRISTIQUES DE LAMPES À ARC

1. Après une interruption de courant ou une baisse importante de voltage, les lampes à arc mettent du temps avant de se rallumer. Dans certains cas, la lampe se rallumera automatiquement après s'être refroidie. Cela dépend de la manière dont le système est réglé pour le statut de mise en marche de la lampe.
2. La position Brûler est Universelle.

Aviso sobre Seguridad

Es muy importante leer TODA la información e instrucciones sobre seguridad que se indica en este manual así como en los documentos adjuntos antes de instalar y operar los productos descritos. Se debe prestar atención a todos los avisos y advertencias durante la instalación y uso de este producto.

Los símbolos de seguridad usados en este manual son los siguientes:



CUIDADO, indica posibles daños al producto.



ADVERTENCIA, indica posibles lesiones o muerte a las personas

LA INFORMACIÓN GENERAL RELACIONADA A LA PROTECCIÓN CONTRAGOLPES DE CORRIENTE ELÉCTRICA, INCENDIO EXPOSICIÓN EXCESIVA A RADIACIÓN ULTRA VIOLETA Y LESIONES A LAS PERSONAS SE PUEDE ENCONTRAR SEGUIDAMENTE:

ADVERTENCIA:

INSTRUCCIONES PARA PROTECCIÓN CONTINUA CONTRA INCENDIO

1. Las luminarias VARI *LITE han sido diseñadas para ser usadas solamente con algunas lámparas. Tome nota del tipo de lámpara (620 Watt LED) antes de reemplazarla. Instalación de otro tipo de lámpara puede ser peligroso.
2. Las luminarias se pueden instalar en cualquier tipo de superficie siempre que se sigan las instrucciones de instalación. Vea las instrucciones detalladas en este manual.
3. Tome nota de los requerimientos de distancia de materiales combustibles u objetos iluminados para las luminarias VARI *LITE .

ADVERTENCIA:

INSTRUCCIONES PARA PROTECCIÓN CONTINUA CONTRA CHOQUE ELÉCTRICO

1. Las luminarias VARI *LITE están diseñadas solamente para lugares secos. La exposición a la lluvia o humedad pueden dañar la luminaria.
2. Desconecte la energía antes de dar servicio a cualquier equipo de VARI *LITE .
3. El servicio debe ser realizado solamente por personal calificado.

ADVERTENCIA:

INSTRUCCIONES PARA PROTECCIÓN CONTINUA CONTRA LA EXPOSICIÓN EXCESIVA DE RADIACIÓN ULTRA VIOLETA

1. Muchas luminarias VARI*LITE usan un tipo de lámpara que produce radiación UV. NO mire directamente a la lámpara.
2. Es peligroso operar luminarias sin lentes o protectores. Debe cambiar los protectores, lentes o pantallas ultravioletas si se aprecia que han sido dañadas, y que su efectividad pudieran estar deteriorada. Por ejemplo, si tuvieran rajaduras o raspaduras profundas.

ADVERTENCIA:

INSTRUCCIONES PARA PROTECCIÓN CONTRA LESIONES DE PERSONAS

1. Las superficies exteriores de las luminarias están calientes durante su operación. Use un equipo de seguridad apropiado (guantes, protección para los ojos, etc.) cuando haga ajustes en el equipo y componentes que están calientes.
2. Cuando las luminarias están en operación la lámpara estará muy caliente. Desconecte la energía y deje que la lámpara se enfríe antes de reemplazarla.
3. Las lámparas de arco emiten radiaciones ultravioletas que pueden ocasionar serias quemaduras a la piel e inflamación a los ojos. Además, las lámparas de arco operan a alta presión y muy alta temperatura. Si la lámpara se rompe puede existir el peligro de lesiones al personal o un incendio ocasionado por las partículas de la lámpara rota que se caen.
4. Use protección para los ojos cuando vuelva a colocar una lámpara nueva.
5. Use un equipo de seguridad apropiado (guantes, protección para los ojos, etc.) cuando trabaje con lámparas dañadas.
6. Si toca la lámpara con las manos limpie la lámpara con alcohol desnaturalizado y con tela sin pelusas antes de instalar o volver a conectar la luminaria.
7. Cambie la lámpara si está dañada o deformada térmicamente.

ADVERTENCIA:

INTERFERENCIA

RF

1. Este es un producto de Clase A. En el ambiente de la casa este producto puede ocasionar radiointerferencia, en cuyo caso, el usuario debe tomar las medidas adecuadas.

CONSIDERACIONES SOBRE LAS CARACTERÍSTICAS DE LA LÁMPARA DE ARCO

1. Las lámparas de arco requieren un período de tiempo para volver a iluminarse después de una interrupción de energía o de una severa caída de voltaje. En algunos casos, la lámpara se volverá a iluminar en forma automática después que se ha enfriado dependiendo de la configuración del sistema de energía de la lámpara.
2. La posición de encendido es universal.

Introduction

About This Manual.....1
 Additional Documentation.....1
 Text Conventions2
 Customer Service.....2

Chapter 1. Description

Features

VLZ WASH Standard Features.....4

Components

Included Items 5
 Items/Accessories 6
 Overview 7

Chapter 2. Installation

Special Warnings

Exceptional Safety Information for the VLZ WASH Luminaire 10

Power and Data Cabling Requirement

Power.....11
 DMX Termination Connector13

Installation Procedures

Hanging the Luminaire 14
 Floor Mounting the Luminaire 16

Powering Up

Power Up and Configuration Procedure17

Addressing

Program Starting Address18
 Program Starting Address Without Calibrating Luminaire18

Chapter 3. Operation

VLZ WASH DMX Channels

VLZ WASH Channel Mapping20
 VLZ WASH Control Channel Functions.....26

VLZ SPOT DMX Mapping

VLZ WASH Color Control28
 Color Mixing.....28
 Fixed Color Wheel 128
 Fixed Color Wheel 229
 Fixed Color Wheels DMX Map30
 VLZ WASH Beam Control.....30
 Strobe.....30

VLZ WASH Luminaire Timing

VLZ WASH Timing Channel Information.....31

Updating Software

Software From Luminaire to Luminaire 33

Chapter 4. Menu System

Menu Operation	
What Is the Menu System?	37
Controls Operation	37
Default State.....	38
Menu Functions	
VLZ WASH Menu System Function Chart.....	39
Menu Function Definitions	42
Self-Tests	
Running Parameter Tests.....	43
Appendix A. Luminaire Care and Routine Maintenance	
Equipment Handling	
Locations/Use	46
LED	46
Servicing	46
Heat.....	46
LED Features/Benefits.....	46
Solid State Electronics	47
Electrostatic Discharge (ESD)	47
Printed Circuit Boards (PCBs).....	47
Troubleshooting	
Error Messages	48
Troubleshooting Guide	49
Routine Maintenance	
LED Replacement	50
Cleaning Optics and Filters.....	51
Followspot Handle Accessory Installation (Optional)	52
Appendix B. Technical Specifications	
VLZ WASH Luminaire.....	55

Introduction

About This Manual

This manual provides necessary information regarding safety, installation, operation and routine maintenance for VARI*LITE VLZ WASH Luminaires. Familiarizing yourself with this information will help you to get the most out of your luminaire.



WARNING: It is important to read ALL accompanying safety and installation instructions to avoid damage to the product and potential injury to yourself or others.

This manual covers the following models:

Model	Part Number	Source
VLZ WASH Luminaire	6.06.02.01.2916-0	620Watt Atria TM SUL620-80-R70-000 LED

Additional Documentation

A service manual, only for Authorized VARI*LITE Service Centers and technicians, of the VLZ WASH Luminaire is available in electronic (PDF) format:

- Luminaire Service Manual
- Testing, Troubleshooting, Component Replacement and Illustrated Parts Breakdown.













Note: Performing maintenance procedures may void the product warranty. Refer to the Vari-Lite Limited Warranty card included in the product shipping package for more information.

For more information on installing DMX512 control systems, the following publication is available for purchase from the United States Institute for Theatre Technology (USITT), "Recommended Practice for DMX512: A Guide for Users and Installers, 2nd edition" (ISBN: 9780955703522). USITT Contact Information:

USITT Inc.
 315 South Crouse Avenue Suite 200
 Syracuse, NY 13210
 Tel: 800-938-7488 or +1-315-463-6463
 Fax: 866-398-7488 or +1-315-463-6525
www.usitt.org

Text Conventions

The following styles and meanings are used throughout this manual:

Style	Meaning
[Button]	Front panel button. Example: Press [MODE/ESC]/ 
   	Press either     arrow button at Menu Display.
MENU	LCD Menu Display read-out. Example: Press     arrows until DMX appears.

Customer Service

Our Goal

At Vari-Lite, we are committed to providing you the highest quality in customer service. Our comprehensive resources are available to help your business succeed and ensure you get the full benefit of being a Vari-Lite customer. Whether your needs are telephone troubleshooting assistance, product training or technical service, our full-time staff of experienced professionals is on-hand to provide support.

How to Reach Us

For assistance in your area, call the dealer from which your product was purchased.

or

Contact an Authorized VARI*LITE Service Center.

or

Contact the Vari-Lite Customer Service Department, 9am -6pm CST Monday through Friday, at the following:

phone: 1-877-VAR LITE (1-877-827-4548) or +1-214-647-7880

email: entertainment.service@philips.com

Additional Resources

For additional resources and documentation, please visit our website at <http://www.philips.com/entertainmentlighting> and follow the Support link.

CHAPTER 1.

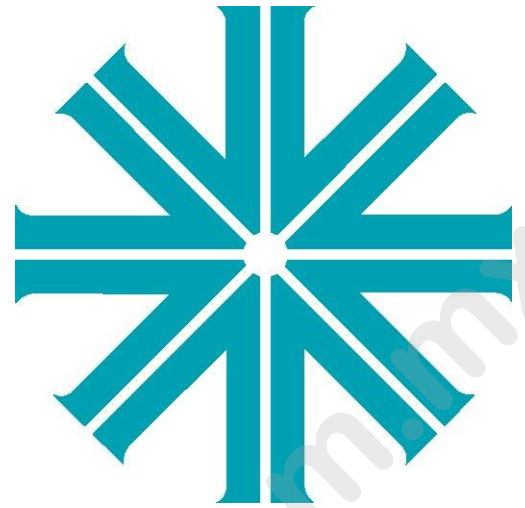

Description

This chapter contains descriptions of luminaire features and components, along with a list of accessories which are available.

- [Features](#)
- [Components](#)

Features



VLZ WASH Standard Features

The VLZ WASH Luminaire has the following standard features:

- Zoom optics system with 8.5° to 52° range in Beam, 12.6° to 54° range in Wash.
- CMY color mixing system.
- Two fixed color wheels.
- Variable CTO color temperature correction wheel.
- Independent, drop-in armature that contains variable frost.
- Full-field dimming system.
- Dual blade strobe system.
- Repositional pan/tilt system.
- Control by DMX512 protocol.
- Fan cooled.
- 620W Atria TM SUL620-80-R70-000 LED.



Note: For more information and product specifications, refer to “Technical Specifications” on page 55.

SPOT Features

Included Items

The following illustration shows all items included with the luminaire:

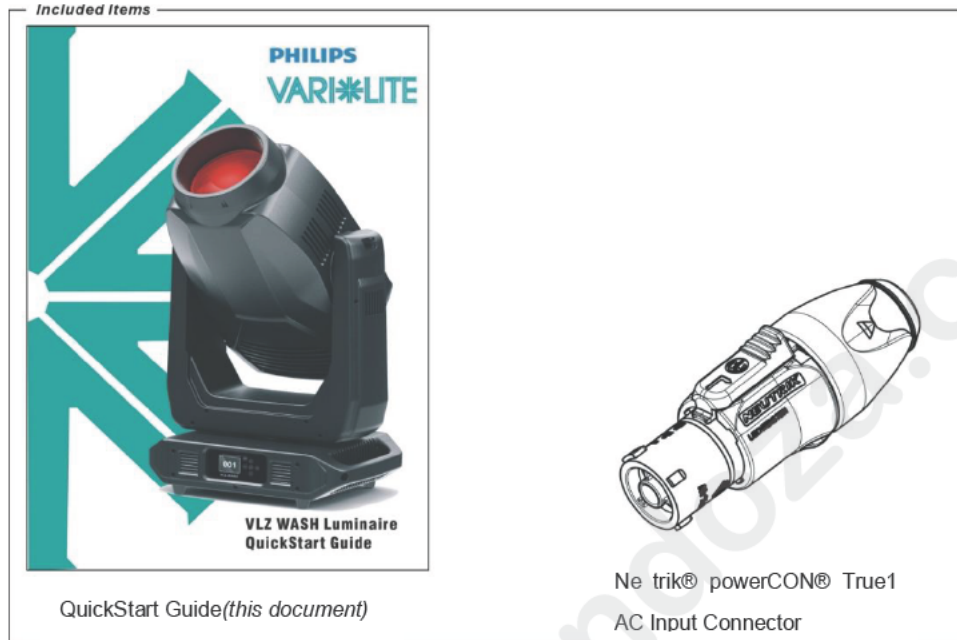

Figure 1-1: VLZ WASH Luminaire Included Items

Note: * Please Check with the local Vari-Lite Office or Authorized Vari-Lite dealer for availability on accessories.

Replacement Items/Accessories

The following optional and/or replacement items can be ordered directly from your Authorized Vari-Lite Dealer. (Please order by Vari-Lite part number.)

Vari-Lite Part Number	Accessory Description
6.04.05.03.0337	Atria TM SUL620-80-R70-000
5.05.01.99.0110-0	Safety Cable Assembly

DESCRIPTION:COMPONENTS

1

Luminaire Overview

The following illustration shows the external luminaire components and controls.

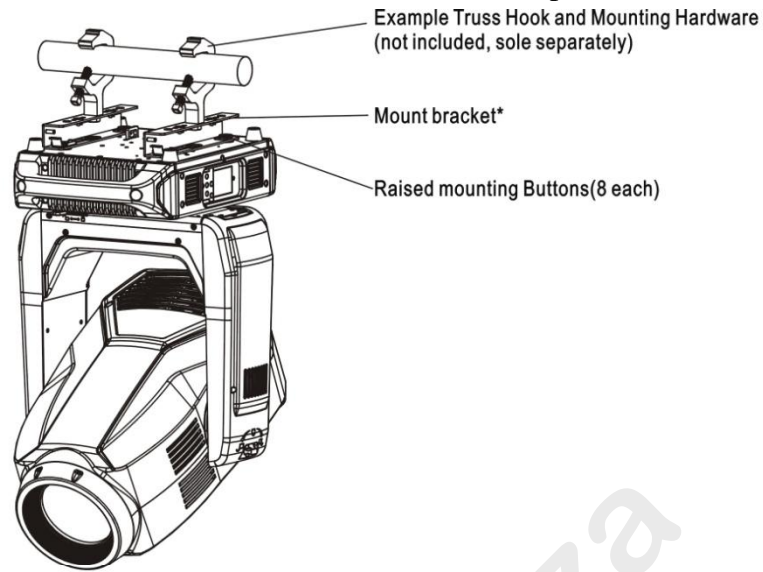

Fit bracket's keyed hole and locking mechanism over raised mounting buttons and slide forward.

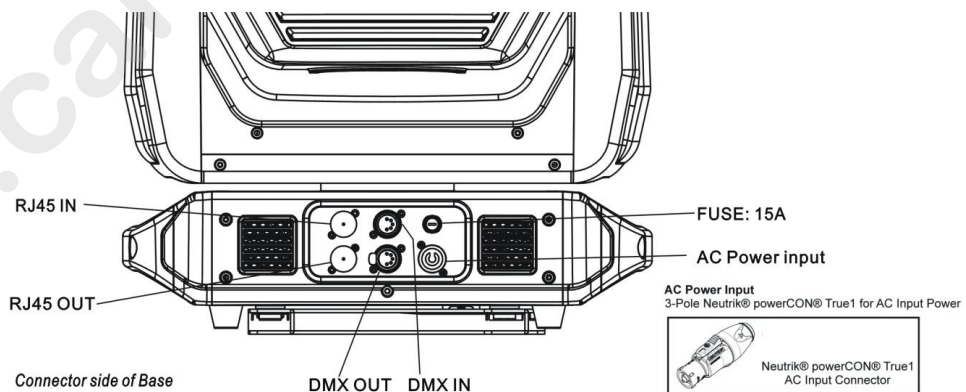
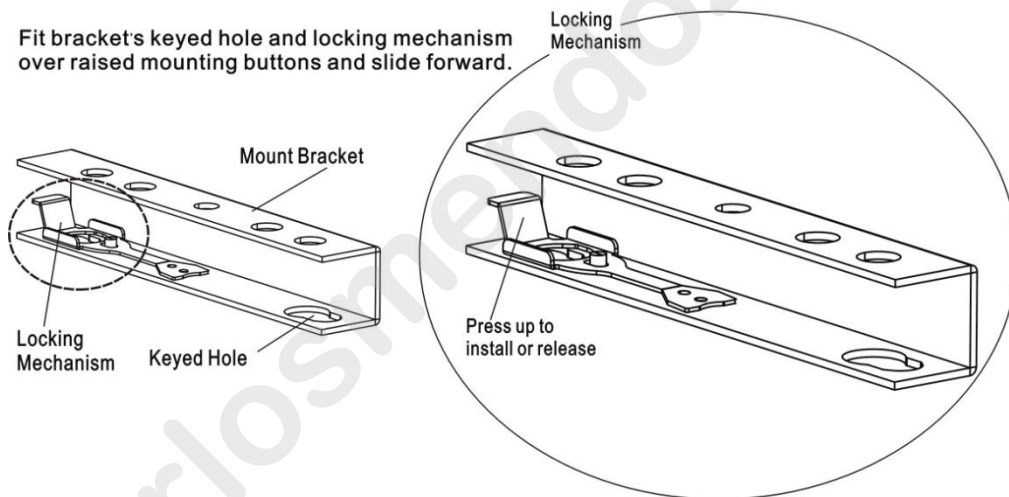

VARI*LITE VLZ WASH Luminaire User's Manual

Notes



www.carlosmendoza.com.mx

CHAPTER 2.

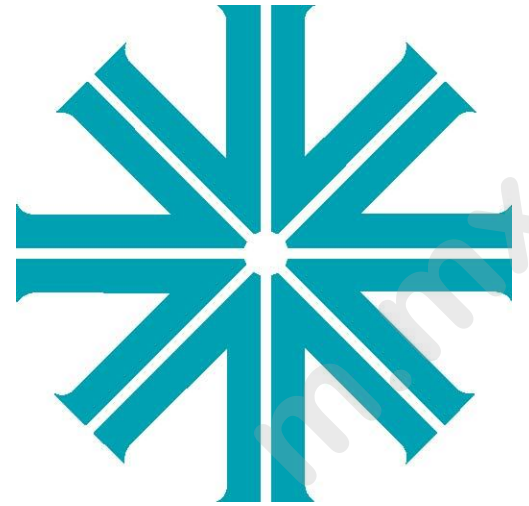

Installation

This chapter contains instructions for installation of the luminaire. It includes connecting power and data, along with instructions for powering up the luminaire for the first time and addressing it within your system.

- **Special Warnings**
- **Power and Data Cabling Requirements**
- **Installation Procedures**
- **Powering Up**
- **Addressing**

Special Warnings

Exceptional Safety Information for the VLZ WASH Luminaire

The light intensity and power density of the VLZ WASH Luminaire exceeds that of other fixtures typically used in this application. The warnings and cautions that follow are critically important to the safe operation of this fixture. This product is for commercial use only by trained professionals only.

If you have any questions about the safe installation and operation of the VLZ WASH Luminaire, please contact Vari-Lite customer service at 1-877-VARI-LITE (1-877-827-4548), +1-214-647-7880, or entertainment.service@philips.com



WARNING: Light Beam Projects Intense Heat. Do not illuminate objects within 2.0 m (6.6 feet) of the VLZ WASH Luminaire. Objects within this range can scorch, melt, or ignite from the heat projected by the light beam.



WARNING: High Intensity Light Output. Do not look directly into the light beam. Avoid looking at nearby surfaces illuminated by the beam. It is hazardous to operate luminaires without lens or shield. Shields, lenses, or ultraviolet screens must be changed if they have become visibly damaged to such an extent that their effectiveness is impaired. For example, by cracks, deep scratches, or coating breakdown.



WARNING: Hot Exterior Surfaces. The exterior surfaces of the luminaire can get very hot - up to 85°C (185°F). Do not touch any surface of the luminaire while it is operating. Keep all combustible materials a minimum of 200 mm (8 inches) away from the luminaire. To maintain cooling fan operation after the LED is doused, keep the luminaire powered on for 5 minutes. Wait an additional 5 minutes before touching the luminaire.



WARNING: Operating Environment. Do not operate the luminaire when the ambient temperature exceeds 45°C (113°F).



WARNING: Approved LED Type. Use only approved LED types in VLZ WASH Luminaire. Users can check the latest version of Vari-Lite Technical Notice TN-248, on the Vari-Lite web site, for all approved LED.

Power and Data Cabling Requirements

Power

The luminaire requires standard AC power distribution from AC100-240V~, 50/60Hz. Current required depends on the AC supply voltage and product model.



Note: The mating Neutrik PowerCon connector is supplied, however, you will need to purchase or construct a cable appropriate for your application.

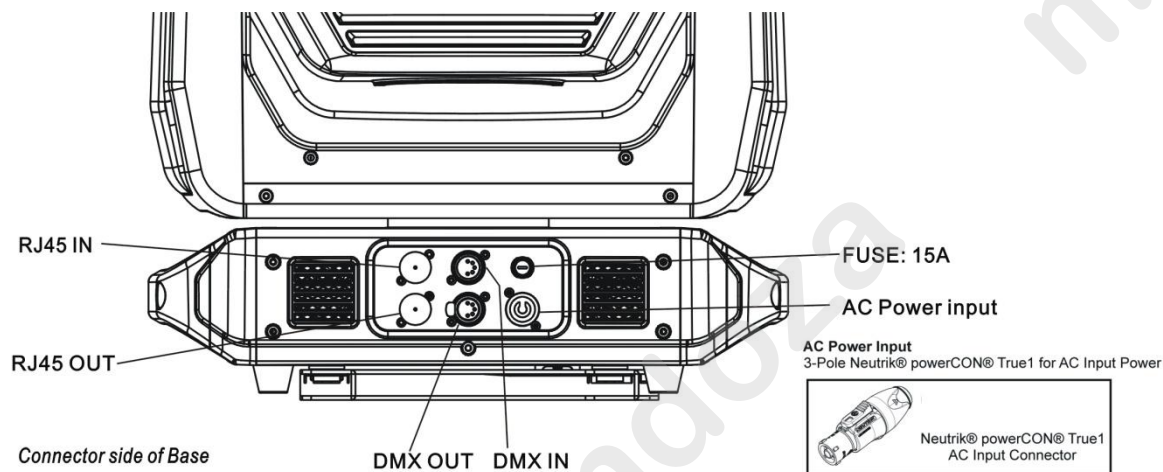

Figure 2-1: Power Connector

Depending on the application, the luminaire's AC input cable may require a different connector. If required, install a new connector meeting your requirements using the following wire color code reference:

Wire*	Connection
Green	AC Ground
White	AC Neutral
Black	AC Line
* International (Harmonized) Standard	



WARNING: DO NOT connect to three-phase service in countries with 240 volt power.

AVERTISSEMENT: NE PAS se connecter au service en trois phases dans les pays avec puissance de 240 volts.

For single-phase power at 240 volts RMS:

Connection	Pin
AC Neutral	X
AC Line	Y
Ground(Earth)	G



For three-phase power at 208 volts RMS:

Connection	Pin
Phase 1	X
Phase 2	Y
Ground (Earth)	G



WARNING: It is not recommended to power any VARI*LITE luminaire from a dimmer - even in 'NONDIM' mode. Dimmer and non-dim modules are not suitable sources of power because their output modifies the AC wave form. This may work for a short time, but will eventually result in power problems, luminaire mis-operation and/or failure and may void the luminaire's warranty.

DMX Termination Connector

A DMX termination connector is required at the last luminaire (or "far end of the line") to prevent signal reflections. Signal reflections may cancel out the signal at certain line lengths, resulting in errors. The terminator is also necessary for software downloads and running tests on multiple luminaires. To construct your own connector, you will need the following components:

- 5-pin, male XLR connector.
- Two 1/4W 5% 120 ohm resistors.

Note: A DMX termination connector assembly is available as an accessory from Vari-Lite. See "Replacement Items/Accessories" on page 6.

Installation Procedures

Hanging the Luminaire

The VLZ WASH Luminaire can be hung horizontally or vertically from any structure designed to work with the type of load created by this moving luminaire. Two mounting truss hooks or other mounting hardware are required. Many compatible truss hooks are available from different manufacturers for your particular needs. A minimum of two hooks per luminaire is required. If mounting method does not use truss hooks, two attachment points, per luminaire, are required.

Install mounting hardware and brackets:

Step 1. Install truss hooks on two provided truss hook brackets as required as shown in **Figure 2-2**.

Step 2. Determine required configuration of bracket installation. Brackets may be installed in many different orientations as shown in **Figure 2-3**.

Step 3. While pulling up on locking mechanism release fit keyed holes onto raised mounting buttons at bottom of enclosure. Slide forward and release locking mechanism to lock in place. Ensure brackets are locked securely.

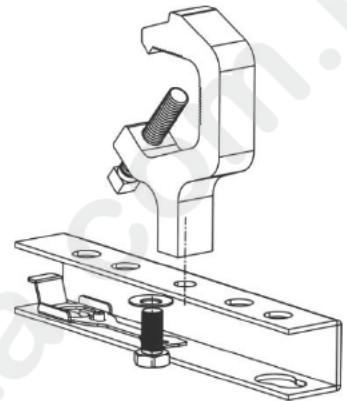
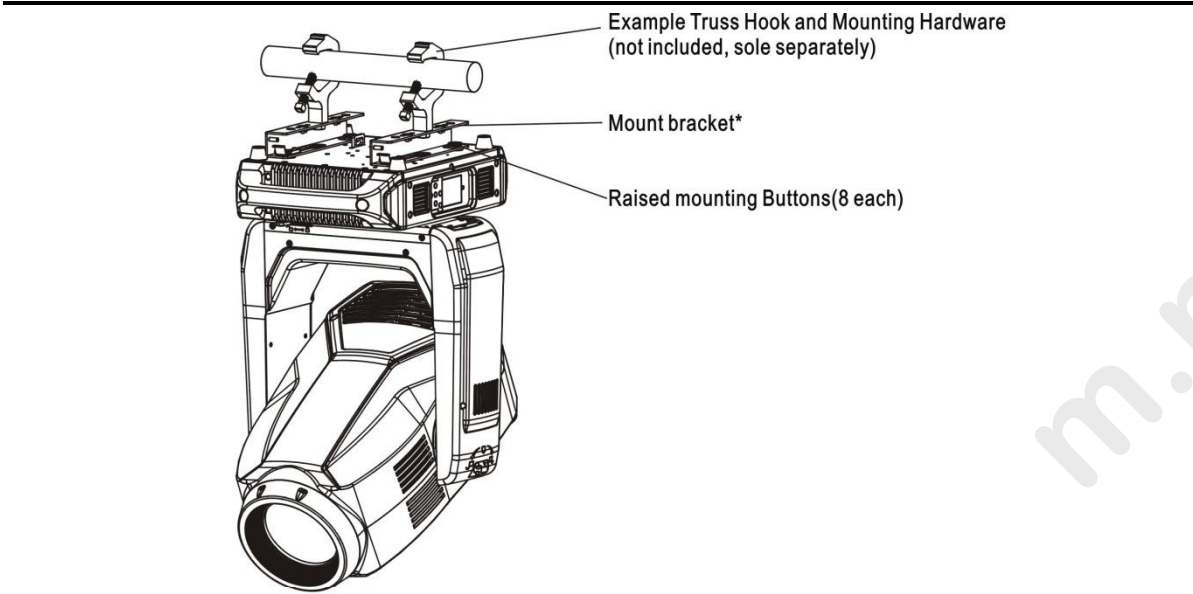

Figure2-2:Truss Hook Installation



WARNING: Ensure that the bracket locking mechanism is fully seated after the bracket is installed on the luminaire.

AVERTISSEMENT: Assurez-vous que le mécanisme de support de verrouillage est complètement inséré après le support est installé sur l'appareil.



Fit bracket's keyed hole and locking mechanism over raised mounting buttons and slide forward.

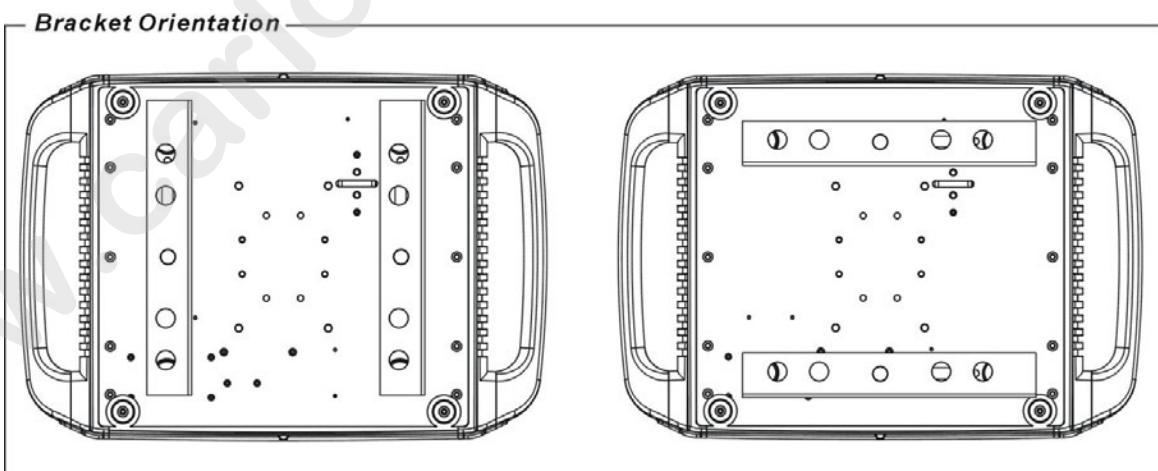
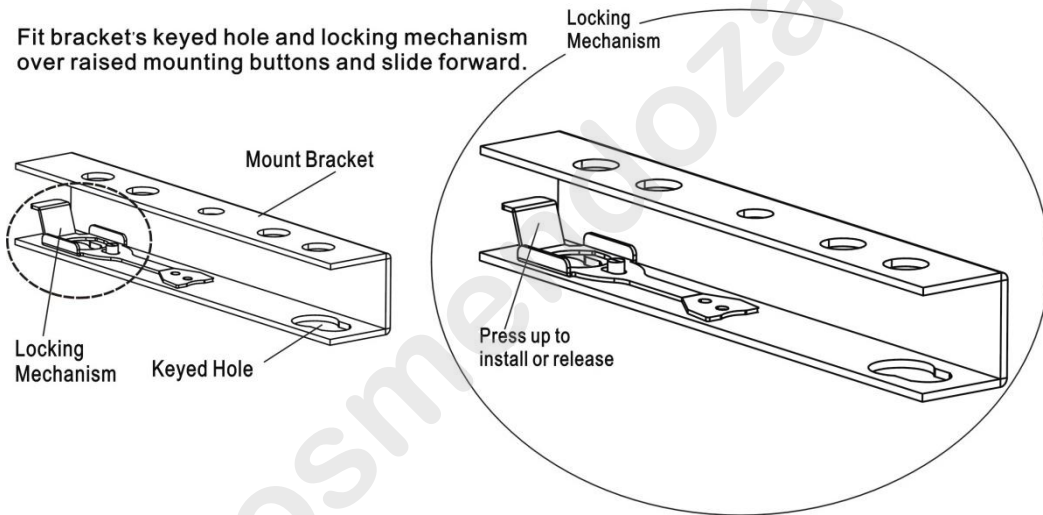

Figure 2-3: Installing Brackets on Luminaire Enclosure

Floor Mounting the Luminaire

All luminaires included in this manual are designed to sit directly on its base in a floor installation application. When used in this type of application, be sure to leave enough space around the luminaire to allow proper, uninterrupted airflow for cooling and movement.



WARNING: Light Beam Projects Intense Heat. Do not illuminate objects within 2.0 m (6.6 feet) of the VLZ WASH Luminaire. Objects within this range can scorch, melt, or ignite from the heat projected by the light beam.

Connecting Data and Power

A maximum of 32 luminaires may be connected in any one DMX data link.

Note: This maximum limit applies to the luminaire "daisy chain" only. Your system or console may require fewer luminaires on a single data link path. Consult your console documentation for more information.

To connect power and data:

- Step 1. Connect data cable from console to first luminaire in chain at DATA IN connector.
- Step 2. If required, connect additional data cables from DATA THRU connectors to DATA IN connectors of remaining luminaires in link.
- Step 3. At last luminaire in link, install male termination connector at DATA THRU connector. (Luminaires and other devices on the same DMX chain may not function properly without termination)

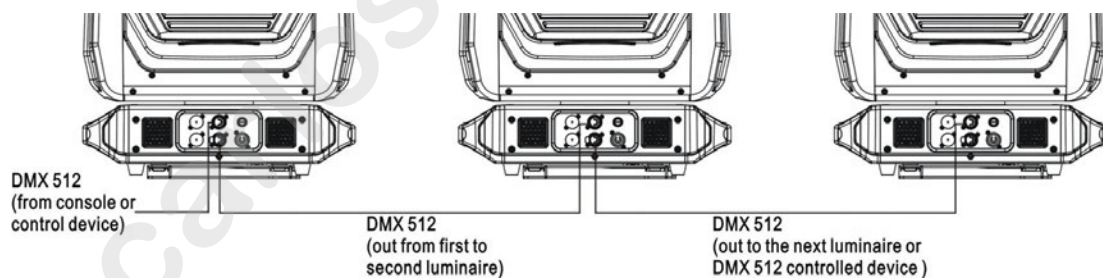

Figure 2-4: Data Link

- Step 4. Connect AC Input Cable connector to power input source.
- Step 5. Dress AC input and data cables and secure them so that they will not interfere with luminaire head and yoke movement.

Powering Up

Power Up and Configuration Procedure

The internal color, gobo, and beam mechanisms will also move through a full range of motion. After calibration, the luminaire head will either stop at its "home" position (which positions the pan axis at mid-rotation and the head parallel to the yoke with the lens pointing away from the luminaire upper enclosure) or move to its current DMX-defined position if DMX data is present. All internal mechanisms also move to their "home" or DMX-defined positions.

Subsequently, depending on the luminaire's setting for Power-Up State (refer to ["VLZ WASH Menu System Function Chart" on page 39](#)).



CAUTION: Before applying power, be sure the luminaire is hung or positioned so that the head and yoke can move freely without restriction. Make sure service tilt and pan locks are disengaged so luminaire moves freely.

To power up:

At each luminaire, apply power by connecting luminaire to input power source (100 to 240VAC). Luminaire will automatically step through following procedure:

- a. Luminaire will cycle through calibration and stop at "home" position.

Addressing

Program Starting Address

The address setting for DMX console controlled systems is entered using the Menu Display (refer to “[Menu Operation](#)” on page 37). The luminaire retains the DMX address even if power is removed.

Note: Refer to your console operating instructions for specific information regarding its addressing requirements.

Program a DMX starting address:

Step 1. Make sure unit is powered and turned on.

Step 2. Press [MODE/ESC] to access menu categories.

Step 3. Use four Arrow (⬆️ ⬇️ ⬅️ ➡️) buttons to navigate through the various options and settings.

Step 4. Once menu item is reached, press OK (⏹️) to access the menu item parameters.

Step 5. Make changes to parameters as desired.

Step 6. Press (⬅️) button to accept changes.

Program Starting Address Without Calibrating Luminaire

It is possible to bypass the calibration sequence and go directly to the Menu Display programming in order to pre-program an address setting.

Program starting address without calibrating luminaire:

- While powering up luminaire, press and hold [MODE/ESC]. Program address as in Program Starting Address above.
 - Press and hold [MODE/ESC] until display changes to the DMX address.
-

Note: The luminaire will require a reset to restore control. See “[VLZ WASH Control Channel Functions](#)” [chapter on page 26](#) for control channel information on luminaire reset.

CHAPTER 3.

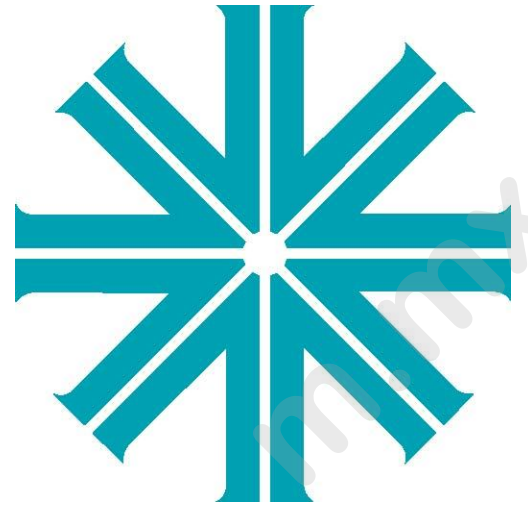

Operation

This chapter contains instructions for operating the luminaire using DMX control and for updating the internal software.

[VLZ WASH DMX Channels](#)

[VLZ WASH DMX Mapping](#)

[VLZ WASH Luminaire Timing](#)

[Updating Software](#)

www.carlosmendoza.com

VLZ WASH DMX Channels

VLZ WASH Channel Mapping

These tables assume a DMX start address of 1. When a different starting address is used, this address becomes channel 1 function and other functions follow in sequence.

Table 3-1: VLZ WASH DMX Channel Mapping

16-Bit Enhanced DMX channel's functions and their values (52 DMX channels):

DMX Channel	Parameter	Range DMX	Defaults	Description
1 2	Intensity High Byte Low Byte	0-65535	0	16-bit control of Fixture Intensity from 0 –100%
3 4	Pan High Byte Low Byte	0 - 65535	32767	16-bit linear control of pan from 0°-540°. With Expanded Movement turned on, 630° of pan is possible
5 6	Tilt High Byte Low Byte	0 - 65535	32767	16-bit linear control of tilt from 0°-270°.
7 8	Edge High Byte Low Byte	0 - 65535	32767	16-bit linear control of edge functions
9 10	Zoom High Byte Low Byte	0 - 65535	32767	16-bit linear control of fixture zoom range between 0 (narrow) to 65535 (wide).
11	Programming Control	0 - 255	0	Used as a control channel for different programmable settings. Set value of desired effect, wait >3 seconds, then set a desired value to 0 (Idle). 0 - 2 → Idle 3 - 5 → Linear Dimming Curve 6 - 10 → Square Law Dimming Curve 11 - 15 → TV Dimming Curve

		16 - 20 51 - 55 56 - 60	→ → →	Architectural Dimming Curve Edge Track ON Edge Track OFF
12 13	Cyan High Byte Low Byte	0 - 65535	0	16 Bit control of cyan color mechanism.
14 15	Yellow High Byte Low Byte	0 - 65535	0	16 Bit control of yellow color mechanism.
16 17	Magenta High Byte Low Byte	0 - 65535	0	16 Bit control of Magenta color mechanism.
18 19	CTO High Byte Low Byte	0 - 65535	0	16 Bit control of CTO mechanism.
20	Color Wheel 1	0 - 255 0 - 17 18 - 43 44 - 83 84 - 118 119 - 155 156 - 192 193 - 228 229 - 255	0 → → → → → → → →	8-bit linear control of Color Wheel 1. See Channel 16 for options. OPEN COLOR 1 - RED (Center at DMX 37) COLOR 2 - YELLOW (Center at DMX 73) COLOR 3 - KELLY GREEN (Center at DMX 109) COLOR 4 - MAGENTA (Center at DMX 145) COLOR 5 - AMBER (Center at DMX 181) COLOR 6 - CONGO BLUE (Center at DMX 217) OPEN END - NO COLOR

DMX Channel	Parameter	Range DMX	Defaults	Description
-------------	-----------	-----------	----------	-------------

21	Color Wheel 1 Control	0 - 255 0 - 5	0 →	Used as a control channel for different movement options of Color Wheel 1. Linear Movement using shortest (quickest) path.
----	---	----------------------	------------	---

		6 - 10 11 - 15 16 - 20 21 - 25 26 - 56 57 - 87 88 - 255	→ → → → → → →	Linear Movement using normal (longest) path. Wheel Spin Forward (Slow to Fast) Wheel Spin STOP Wheel Spin Reverse (Slow to Fast) Color Shake Quickest Path (Slow to Fast) Color Shake Normal Path (Slow to Fast) Reserved Values
22	Color Wheel 2	0 - 255 0 - 17 18 - 43 44 - 83 84 - 118 119 - 155 156 - 192 193 - 228 229 - 255	0 → → → → → → → →	8-bit linear control of Color Wheel 1. See Channel 16 for options. OPEN COLOR 1 - TBC (Center at DMX 37) COLOR 2 - TBC (Center at DMX 73) COLOR 3 - TBC (Center at DMX 109) COLOR 4 - TBC (Center at DMX 145) COLOR 5 - TBC (Center at DMX 181) COLOR 6 - TBC (Center at DMX 217) OPEN END - NO COLOR
23	Color Wheel 2 Control	0 - 255 0 - 5 6 - 10 11 - 5 16 - 20 21 - 25 26 - 56 57 - 87 88 - 255	0 → → → → → → → →	Used as a control channel for different movement options of Color Wheel 1. Linear Movement using shortest (quickest) path. Linear Movement using normal (longest) path. Wheel Spin Forward (Slow to Fast) Wheel Spin STOP Wheel Spin Reverse (Slow to Fast) Color Shake Quickest Path (Slow to Fast) Color Shake Normal Path (Slow to Fast) Reserved Values
24	Beam Shaper	0 - 5 6 - 10 11 - 15 16 - 20 21 - 255	→ → → → →	Open Index (Beam Shape) Rotate Normal (Beam Shaper) Rotate with Mega Stepping (Beam Shaper) Reserved Values
25	Beam Shaper Rotate/ Index High Byte	0 - 65535 0~126 127~128 129- 255	32767 → → →	16-bit control of prism rotation and index. Rotate Fast to Slow <<< Rotation STOP Rotate Slow to Fast >>>
26	Low Byte			

27 28	Frame 1A High Byte Low Byte	0 - 65535	0	16 Bit Control of Framing Shutter 1A from open (DMX 0) to Full (DMX 65535).
29 30	Frame 1B High Byte Low Byte	0 - 65535	0	Controls Framing Shutter 1B from Open (DMX 0) to Full (DMX 255).
31 32	Frame 2A High Byte Low Byte	0 - 65535	0	Controls Framing Shutter 2A from Open (DMX 0) to Full (DMX 255).
33 34	Frame 2B High Byte Low Byte	0 - 65535	0	Controls Framing Shutter 2B from Open (DMX 0) to Full (DMX 255).
35 36	Frame 3A High Byte Low Byte	0 - 65535	0	Controls Framing Shutter 3A from Open (DMX 0) to Full (DMX 255).
37 38	Frame 3B High Byte Low Byte	0 - 65535	0	Controls Framing Shutter 3B from Open (DMX 0) to Full (DMX 255).
39 40	Frame 4A High Byte Low Byte	0 - 65535	0	Controls Framing Shutter 4A from Open (DMX 0) to Full (DMX 255).
41 42	Frame 4B High Byte Low Byte	0 - 65535	0	Controls Framing Shutter 4B from Open (DMX 0) to Full (DMX 255).
43 44	Frame Rotate High Byte Low Byte	0 - 65535	32767	Controls Framing Shutter mechanism from +/- 90°

DMX Channel	Parameter	Range DMX	Defaults	Description
-------------	-----------	-----------	----------	-------------

45	Frost	0 - 255	0	Insert control of frost mechanism with the following values.
		0 - 50	→	Open - No Frost or Diffusion
		51 - 100	→	Insert Light Diffusion
		101 - 150	→	Insert Heavy Frost

		151 - 200	→	Insert both Light Diffusion and Heavy Frost
46	Strobe	0 - 255 0 - 3 4 - 6 7 - 32 33 -58 59 -84 85 -110 111 -136 137 -162 163 -188 189 -214 215 -240	0 → → → → → → → → → → →	Controls Strobe functionality. Open Closed Normal Strobe - Slow to Fast Random Strobe - Slow to Fast Random Sync - Slow to Fast Pulse > - Slow to Fast Pulse > Random - Slow to Fast Pulse > Random Sync - Slow to Fast Pulse < - Slow to Fast Pulse < Random - Slow to Fast Pulse < Random Sync - Slow to Fast
47	Focus Timing	0 - 255	255	Adjustment of fixture timing to control Pan/Tilt mechanisms. - See Timing Channel Chart in User Manual
48	Optics Timing	0 - 255	255	Adjustment of fixture timing to control lensing mechanisms. See Timing Channel Chart in User Manual
49	Color Timing	0 - 255	255	Adjustment of fixture timing to control color mechanisms. - See Timing Channel Chart in User Manual
50	Beam Timing	0 - 255	255	Adjustment of fixture timing to control beam shaping mechanisms. - See Timing Channel Chart in User Manual
51	Gobo Timing	0 - 255	255	Adjustment of fixture timing to control gobo mechanisms. - See Timing Channel Chart in User Manual
52	Luminaire Control	0 - 255 0 - 5 6 - 10 11 - 15 16 - 20 21 - 25	0	Control Channel used for full fixture settings, lamp controls, and miscellaneous modes. Set desired value of desired effect, wait >3 seconds, then set value to 0 (Idle). Idle (Default) Full Luminaire ReCal - Also Used to Wake fixture up from shutdown Reserved Values Reserved Values Fixture Shutdown

	26 - 30	Display - Menu ON
	31 - 35	Display - Menu OFF
	36 - 40	ReCal Position
	41 - 45	ReCal Color
	46 - 50	Reserved Values
	51 - 55	ReCal Beam
	56 - 60	ReCal Optics
	61 - 65	Reserved Values
	66 - 70	Reset Fixture to Defaults - See Manual for a list of factory defaults.
	71 - 75	Full Luminaire Reboot. This command will reset all processors in fixture, then ReC l all parameters.
	76 - 80	Fixture Status On/Off. This command will enable the display to show fixture status for 5 min. After this time, displ ys will return to default configuration. Repeating this command in less than 5 minute will behave as a toggle.
	81 - 85	Stand rd Mode Fixture operates at maximum output (D fault)
	86 - 90	Studio Mode - Reduced output with lower fan ettings
	91 - 255	Reserved Values

Notes:

- Default Values: Denotes recommended console default settings.
- Use of Timing Channels The default value setting in the profile should be 255 (proportional control) to allow smooth movement when using console timing. The Timing channel data hould change as a snap. A zero value will give the fastest move but without any smoothing, this can look steppy in console-timed moves.
- To use a timing hannel instead of console timing it is necessary to set the timing channel to the desired value and set cue and/or parameter time to zero. A combination of time controls can produce unexpected results. Refer to [“VLZ WASH Timing Channel Information” on page 31](#) for more information.
- Timing Channel Control: The luminaire uses the timing channel value to calculate a smooth continuous movement for a given time and transition.

VLZ WASH Control Channel Functions

Control channel functions allow special actions such as reset and partial recalibration. These must be executed with zero time transition or with timing disabled. Discrete values must be used; not manual controls such as faders or encoders (see chart below for values).

Reset - resets all luminaire mechanisms.

Partial Recalibration - resets only the target mechanism (color, frost, zoom, etc.) without affecting others.

Table 3-2: VLZ WASH Control Channel

DMX Channel	Parameter	Range DMX	Defaults	Description
52	Luminaire Control	0 - 255		Control Channel used for full fixture settings, lamp controls, and miscellaneous modes. Set discrete value of desired effect, wait >3 seconds, then set value to 0 (Idle).
		0 - 5	→	Idle (Default)
		6 - 10	→	Full Luminaire ReCal Also Used to Wake fixture up from shutdown
		11 - 15	→	Reserved Value
		16 - 20	→	Reserved Value
		21 - 25	→	Fixture shutdown
		26 - 30	→	Display - Menu ON
		31 - 35	→	Display Menu OFF
		36 - 40	→	ReCal Position
		41 - 45	→	ReCal Color
		46 - 50	→	Reserved Values
		51 - 55	→	ReCal Beam
		56 - 60	→	ReCal Optics
		61 - 65	→	Reserved Values
		66 - 70	→	Reset Fixture to Defaults - See Manual for a list of factory defaults.
		71 - 75	→	Full Luminaire Reboot. This command will reset all processors in fixture, then ReCal all parameters.
		76 - 80	→	Fixture Status On/Off. This command will enable the display to show fixture status for 5 min. After this time, displays will return to default configuration. Repeating this command in less than 5 minutes will behave as a toggle.
81 - 85	→	Standard Mode - Fixture operates at maximum output (Default)		
86 - 90	→	Studio Mode - Reduced output with lower fan settings		
91 - 255	→	Reserved Values		

To use control channel functions:

Step 1. Select an action to be sent.

Step 2. Set control channel value for desired action (for example, 36 for ReCal). Hold value for 3 seconds.

Step 3. Set control channel value to zero. (This must occur without any scaling values. Action will be voided if other values are detected between action value and zero.)

Note: A numerical keypad is suggested for sending values. An encoder or fader does not allow for a quick value change, which is required to effect the control functions.

VLZ WASH DMX Mapping

VLZ WASH Color Control

The luminaire's color system is composed of a CMY color mixing mechanism and two fixed color wheels. The follow sections describe these components.

Color Mixing

The color mixing mechanism is made up of four graduated color disks: cyan, magenta, yellow and CTO (color temperature orange). These disks provide full-spectrum color crossfades from pastel to saturated color.

Table 3-3: DMX Map for Cyan, Magenta, Yellow and CTO Colors

DMX Channel	Parameter	Range DMX	Defaults	Description
12 13	Cyan High Byte Low Byte	0 - 65535	0	16 Bit control of cyan color mechanism.
14 15	Yellow High Byte Low Byte	0 - 65535	0	16 Bit control of yellow color mechanism.
16 17	Magenta High Byte Low Byte	0 - 65535	0	16 Bit control of Magenta color mechanism.
18 19	CTO High Byte Low Byte	0 - 65535	0	16 Bit control of CTO mechanism.

Fixed Color Wheel 1

Fixed color wheel 1 offers timed changes, half and full frame positions, and various spin rates in either direction. The wheel contains six positions, one being open. The following illustration (Figure 3-1) shows the standard positions and color configuration for fixed color wheel 1:

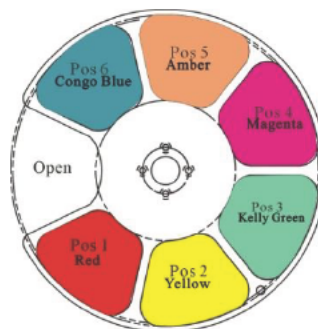

Note: Color are simulated and are for position reference only.

Figure 3-1: Fixed Color Wheel 1 Standard Filters / Positions

Table 3-4: VLZ WASH Fixed Color Wheel 1 Standard Configuration Chart

Position	Color Filter	Part Number
1	Red	6.03.05.03.2519
2	Yellow	6.03.05.03.2520
3	Kelly Green	6.03.05.03.2521
4	Magenta	6.03.05.03.2522
5	Amber	6.03.05.03.2523
6	Congo Blue	6.03.05.03.2524

Fixed Color Wheel 2

Fixed color wheel 2, like fixed color wheel 1, offers timed changes half and full frame positions, and various spin rates in either direction. The wheel contains six positions, one being open. The following illustration (Figure 3-2) shows the standard positions and color configuration for fixed color wheel 2:

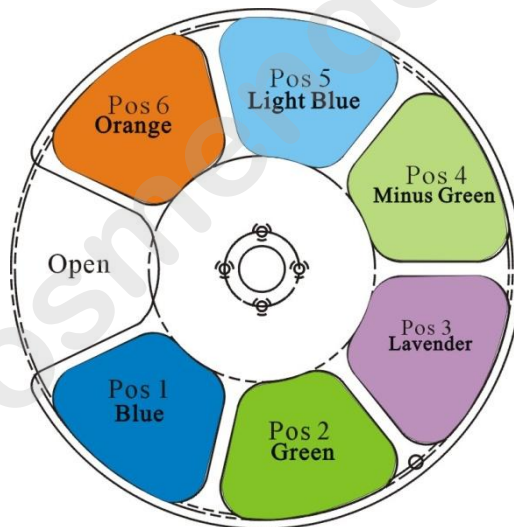

Note:Color are simulated and are for position reference only.

Figure 3-2: Fixed Color Wheel 2 Standard Filters / Positions

Table 3-5: VLZ WASH Fixed Color Wheel 2 Standard Configuration Chart

Position	Color Filter	Part Number
1	Blue	6.03.05.03.2525
2	Green	6.03.05.03.2526
3	Lavender	6.03.05.03.2527
4	Minus Green	6.03.05.03.2528
5	Light Blue	6.03.05.03.2529
6	Orange	6.03.05.03.2530

Fixed Color Wheels DMX Map

Table 3-6: VLZ WASH DMX Map for Fixed Color Wheels 1 and 2

DMX Channel	Parameter	Range DMX	Defaults	Description
20	Color Wheel 1	0 - 255	0	8-bit linear control of Color Wheel 1. See Channel 16 for options
		0 - 17	→	OPEN
		18 - 43	→	COLOR 1 - RED (Center at DMX 37)
		44 - 83	→	COLOR 2 - YELLOW (Center at DMX 73)
		84 - 118	→	COLOR 3 - KELLY GREEN (Center at DMX 109)
		119 - 155	→	COLOR 4 - MAGENTA (Center at DMX 145)
		156 - 192	→	COLOR 5 - AMBER (Center at DMX 181)
		193 - 228	→	COLOR 6 - CONGO BLUE (Center at DMX 217)
		229 - 255	→	OPEN END - NO COLOR
		22	Color Wheel 2	0 - 255
0 - 17	→			OPEN
18 - 43	→			COLOR 1 - TBC (Center a DMX 37)
44 - 83	→			COLOR 2 - TBC (Center a DMX 73)
84 - 118	→			COLOR 3 - TBC (Cen r a DMX 109)
119 - 155	→			COLOR 4 - TBC (Cente at DMX 145)
156 - 192	→			COLOR 5 - TBC (Center at DMX 181)
193 - 228	→			COLOR 6 - BC (Center at DMX 217)
229 - 255	→			OPEN END - NO COLOR

VLZ WASH Beam Control

Strobe

Table 3-7: VLZ WASH DMX Map for Strobe

DMX Channel	Parameter	Range DMX	Defaults	Description
46	Strobe	0 - 255	0	Controls Strobe functionality.
		0 - 3	→	Open
		4 - 6	→	Closed
		7 - 32	→	Normal Strobe - Slow to Fast
		33 - 58	→	Random Strobe - Slow to Fast
		59 - 84	→	Random Sync - Slow to Fast
		85 - 110	→	Pulse > - Slow to Fast
		111 - 136	→	Pulse > Random - Slow to Fast
		137 - 162	→	Pulse > Random Sync - Slow to Fast
		163 - 188	→	Pulse < - Slow to Fast
		189 - 214	→	Pulse < Random - Slow to Fast
		215 - 240	→	Pulse < Random Sync - Slow to Fast

VLZ WASH Luminaire Timing

VLZ WASH Timing Channel Information

Timing channel control improves the timed moves of certain groups of parameters. We provide up to five timing channels - Focus (pan and tilt), Optics Time (lens), Color Time (color parameters), Beam Time (beam parameters), and Gobo Time (gobo parameters).

Types of timing control:

- **Timing Control Channel:** the luminaire uses its timing channel value to calculate a smooth continuous movement for a given time and transition.
- **Console Timing:** the console calculates the time duration between the DMX increments to be sent for a given time and transition.

Guidelines:

- Timing channels support time values of up to six minutes.
- To use a timing channel instead of console timing, it is necessary to set the timing channel to the desired value and set cue and/or parameter time to zero. A combination of time controls can produce unexpected results.
- The default value setting in the profile should be 255 (proportional control) to allow smooth movement when using console timing.
- The timing channel data should change as a snap. A zero value will give the fastest move, however, without any smoothing this can appear "steppy" in console timed moves.

Note: Some parameters have been excluded from the timing channels. Wheel spin and gobo rotation rate changes are not affected by timing channels.

Table 3-8: VLZ WASH Luminaire Channel Function / Timing Channel Relationship

DMX Channel	Parameter	Rang DMX	Defaults	Description
47	Focus Timing	0 - 255	255	Adjustment of fixture timing to control Pan/Tilt mechanisms. - See Timing Channel Chart in User Manual
48	Optics Timing	0 - 255	255	Adjustment of fixture timing to control lensing mechanisms. - See Timing Channel Chart in User Manual
49	Color Timing	0 - 255	255	Adjustment of fixture timing to control color mechanisms. - See Timing Channel Chart in User Manual
50	Beam Timing	0 - 255	255	Adjustment of fixture timing to control beam shaping mechanisms. - See Timing Chan
51	Gobo Timing	0 - 255	255	Adjustment of fixture timing to control gobo mechanisms. - See Timing Channel Chart in User Manual

A timing value of zero is full speed. A time value of 100% (or DMX 255) enables the associated parameter(s) to follow cue fade time (console time) rather than the timing channel.

Note: The particular storing syntax for your console, as well as instructions on how to write part cues, can be found in the operation manual for that console.

To use these channels, you must:

Step 1. Create the cue, including color, gobo, edge and frost as required.

Step 2. Decide which fixtures and which parameter groups will use timing channels.

Step 3. Assign a value to the particular timing channel(s) you wish to use (for timing information, see chart on next page).

Step 4. Set console timing (or cue fade time) for parameters and timing channels to zero seconds.

Step 5. Store cue.

Note: Avoid changing timing channel values in a fading cue. This can cause unexpected behavior in the luminaire as the timing channel value is updated over time. Timing channel values and the final destination of the parameters affected by the timing channel should always be sent in a zero count.

Updating Software

Transferring Software From Luminaire to Luminaire

It is possible to transfer specific software versions between luminaires. As in the case of installing new software versions, multiple luminaires can be programmed at the same time if they are data linked together (refer to [“Connecting Data and Power”](#) on page 11), however a maximum of 32 luminaires can be updated at once.

Hardware Requirements

A DMX termination connector is used in this process. Refer to page 11 for more information regarding the construction of this connector.

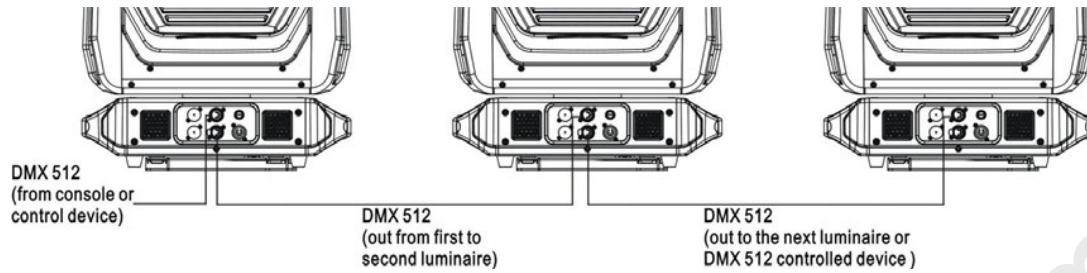

Figure 3-3: Software Transfer Setup

Transfer Procedure

This procedure is used to transfer software versions between luminaires.

- Step 1. At last luminaire, install DMX termination connector into DATA THRU XLR connector.
- Step 2. At master luminaire (first in chain) Menu Display, press [MODE/ESC].
- Step 3. Press arrows until Fixture appears
- Step 4. Press arrows until Cross load appears. Press .
- Step 5. Unplug DMX From Console? will be displayed. Press to accept.
- Step 6. Once download is complete, luminaire will automatically recalibrate. Once recalibration is complete, recalibrate luminaire one additional time.

Verify software version at luminaire:

- Step 1. At Menu Display press [MODE/ESC].
- Step 2. Press arrows until Fixture appears. Press .
- Step 3. Press arrows until Version appears. Press .

Part 1 of the version will be displayed as VXXX.

Press [Enter] to display part 2 of version. This will be displayed as a date (MM/DD/YY). For example, 03/18/17 (March 18, 2017).

Press [Enter] to display part 3 of version. This will be displayed as a time (HH:MM). For example, 16.36 = 4:36 pm)

Notes

www.carlosmendoza.com.mx

CHAPTER 4.

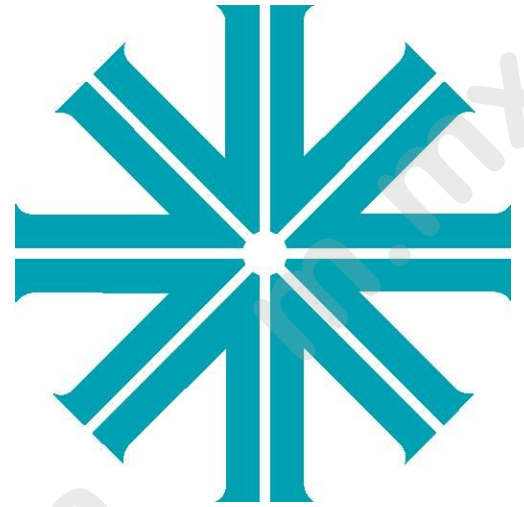

Menu System

This chapter contains instructions for operating the luminaire using the Menu Display feature.

- [Menu Operation](#)
- [Menu Functions](#)
- [Self-Tests](#)

www.carlosmendoza.com

Menu Operation

What Is the Menu System?

The menu system is a programmable set of commands used to configure, address, operate, and test the luminaire. The menu system is controlled at the Menu Display available at the enclosure input panel.



Figure 4-1: Menu Display Location

Controls Operation

The menu system is controlled by an MODE/ESC, , and four Arrow (   ) buttons. These buttons function are shown in Figure 4-2.

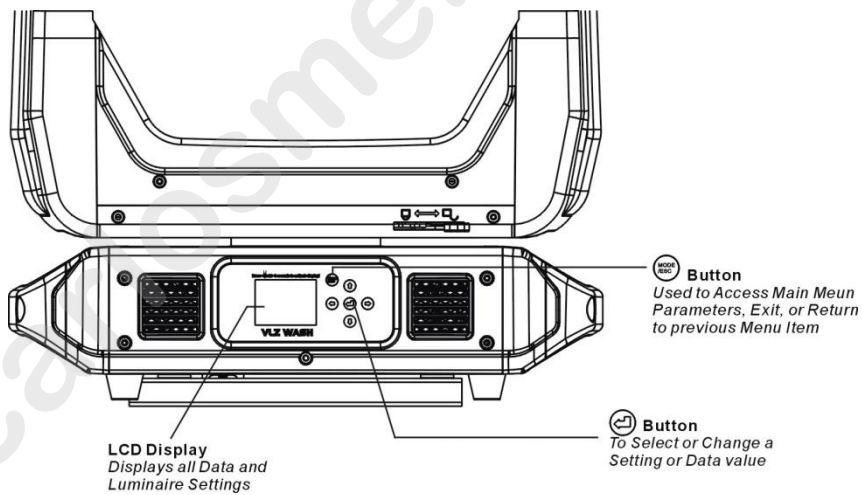

Figure 4-2: Menu Display Location

* The arrows will have opposite functions if the luminaire is hung upside down in a hanging orientation due to the automatic orientation feature. In other words, the arrow pointing downward always functions as down/decrease and the arrow pointing upward always functions as up/increase regardless of the luminaire orientation.

Default State

The menu display's default state during normal operation is to display the DMX address. After 40 seconds of inactivity at the display, it will change to the default state.





After longer periods of inactivity, the menu display will switch to its off state. The default state for this feature is 30 seconds, however, different time lengths can also be programmed





To program a different time length for menu off feature:





Step 1. Press [MODE/ESC] access the main menu.

Step 2. Once enabled, the menu will function as normal with only the following sub-menu sections active:

- Address
- Configure
- DMX
- Fixture
- Manual Control
- Test

Step 3. Press     choose the "Configure", and press .

Step 4. Press     choose the "Display", and press .

Step 5. Press     choose the "On Time", and press .

Step 6. Press     choose "3 Sec", "5 Min", "10 Min", "On" when you need.

Menu Functions

VLZ WASH Menu System Function Chart

Table 4-1: VLZ WASH Menu System Chart

Address	001~512			(Default 001)
Configure	LED	Power Level	Standard	(Default)
			Studio	
		Curve	Idle	
			Linear Dimming	
			Square Law Dim.	(Default)
			TV Dimming	
	Architectural			
	Refresh Freq	900~25000Hz	(Default 1200Hz)	
	Gamma	2.0~2.8	(Default 2.0)	
	Pan/Tilt	Movement	Enable	(Default)
			Disable	
		Speed	Normal	(Default)
			VLZ Match	
	Head Motors	Movement	Enable	(Default)
			Disable	
	Display	Orientation	Auto	(Default)
			Up	
			Down	
		On Time	30 Sec	(Default)
			5 Min	
	10 Min			
	On			
	Reset Defaults	Are you sure?		
	Select Signal	DMX Only		
Art Net On IP2				
Art-Net On IP10				
Set Artnet	Start Universe	000~255	(Default 000)	
	Ethernet IP	XXX. XXX. XXX. XXX		
	Ether Mask IP	XXX. XXX. XXX. XXX		
DMX	D	Ch 1 - Intensity XXX (Value)		
		Ch 2 - Intensity Fine XXX (Value)		
			
	Pan/Tilt	Swap Pan/Tilt	Off	(Default)
			On	
		Invert Pan	Off	(Default)
			On	
		Invert Tilt	Off	(Default)
			On	
	DMX Mode	16-bit Enh		
16-bit				

Table 4-1: VLZ SPOT Menu System Chart

Fixture	Status	(No Errors... or displays a list of errors)			
	Recalibrate (Fixture)	Are you sure?			
	Reboot Fixture	Are you sure?			
	Version	VXXX	MM/DD/YY	HH:MM	
	Fixture Hours	XXXXXX h			
	Crossload (Software)	Unplug DMX From Console?			
	Service	Set Position Cal	Pan		
			Tilt		
			Re. Pos. Off e		
			ReCal Positi n		
		Color Offse	Cyan		
			Magenta		
			Yellow		
			CTO		
			Color Wheel1		
			Color Wheel2		
			Re. Col. Offset		
			ReCal Color		
		Beam Offset	Frame 1A		
			Frame 1B		
			Frame 2A		
Frame 2B					
Frame 3A					
Frame 3B					
Frame 4A					
Frame 4B					
Frame Rot					
Re. Beam Offset					
ReCal Beam					
Optics Offset	Edge				
	Zoom				
	BeamShaper				
	BeamShaper_R				
	Frost				
	Frost 2				
	Re. Opt. Offset				
ReCal Optics					
Diagnostics	Fan Check				
	Board Check				
	Sensor Check				
	Debug				

Table 4-1: VLZ WASH Menu System Chart

Manual Control	Intensity	Value 0 - 255	(Default 0)	
	Intensity fine	Value 0 - 255	(Default 0)	
	(Default 0)	
Test	All Test	(Run 'ALL TEST')		
	Pan/Tilt Test	(Run 'PAN/TILT TEST')		
	Test Channel	Intensity		(Run Intensity test)
		Pan		(runPan test)
	
	Encoder Pan	XXXXXXXX - Displays Pan Encoder		
Encoder Tilt	XXXXXXXX - Displays Tilt Encoder			

Menu Function Definitions

For easy reference, each possible menu item is listed alphabetically in the first column by its display abbreviation. The second column follows with a definition of the abbreviation and then a third column provides an explanation of its purpose and function.

www.carlosmendoza

m.mx

Self-Tests

Running Parameter Tests

The luminaire is capable of running self-tests by using the Testmenu functions.

When running tests on multiple luminaires, a DMX termination connector is required at the last luminaire in the link. Refer to [“Connecting Data and Power” on page 11](#) for more information regarding the construction of this connector.

Note: After 10 seconds of inactivity, the menu display will change to the default state showing the address.

Notes

www.carlosmendoza.m.mx

APPENDIX A

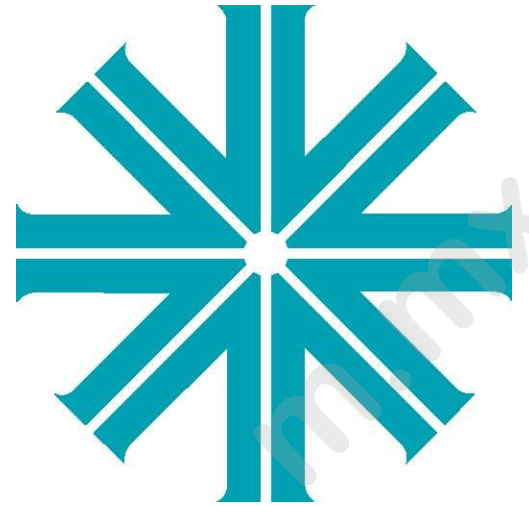

Luminaire Care and Routine Maintenance

This appendix provides instructions for troubleshooting and routine maintenance which may be necessary during the life of the luminaire.

- [Equipment Handling](#)
- [Troubleshooting](#)
- [Routine Maintenance](#)



WARNING: All maintenance procedures are to be performed with power removed from the luminaire. Never remove cover or backcap while LED is in operation.

Equipment Handling

Below are some basic tips and information on handling luminaires and their associated components.



Locations/Use

VARI*LITE luminaires are designed for dry locations only. Exposure to rain or moisture (including, but not limited to, fog machines, misters, etc.) may damage luminaire.

LED

The Atria SUL series bring the more cost-effective high power LED engines to entertainment lighting with high brightness, compact size and excellent thermal management. Proprietary technology in secondary optics delivery high directional lighting with concentrate emitting angle, which makes maximum lighting efficiency available in lighting fixture.

Servicing

- When handling LED, hold it by the ceramic base while wearing cotton gloves or finger cots. Do not touch the glass envelope. If you touch the glass with bare fingers, immediately wipe off any fingerprints with isopropyl alcohol.
- Use care when opening and closing the rear castings (or covers) of luminaires and cleaning reflectors.

Heat

When LED are lit, the interior of the luminaires becomes very hot. To aid in the airflow circulation within the luminaires, after dousing the LED, wait ten minutes before removing power to the luminaires. This will provide enough time for the equipment fan to cool off the unit. Users should wait until the unit is cool to the touch before servicing or handling.

LED Feature /Benefits

- Extremely high lm/mm²
- Small aperture size and ultra-narrow lighting emitting angle
- Compact LED-engine solution with unique secondary optics mounted
- High Color rendering index is available
- Reliable packaging with advanced thermal management
- Lumen maintenance of greater than 70% after 20,000 hours
- Most cost-effective solution in the same level performance of LED engine

Note:Based on CW driver current. Sustained operation beyond recommended drive current values may result in reduced life time. Normal operating thermistor resistance should stay within recommended limits. Lifetime depends on thermal management. Input power and thermal system must be properly managed to ensure life time.

Solid State Electronics



Electrostatic Discharge (ESD)

Electrostatic discharge (ESD) presents a significant danger to solid state electronic components (semiconductor devices and PC board assemblies). Static electricity can build on a variety of common objects (including people) simply by handling or moving. ESD rarely results in immediate failure of a component, but shows up later as an intermittent problem or severely reduces the life of the component. All VARI***LITE** equipment uses solid state electronics and appropriate precautions to protect them should be observed when servicing.

Printed Circuit Boards (PCBs)

All PC boards should be shipped in electrostatic shielding bags. When handling PC boards or components, devices such as conductive mats and conductive wrist straps should be used whenever possible. If these precautionary devices are not available, handling of PC boards and components should be avoided.



CAUTION: Black foam (used to package solid state electronics) should never be used for packing batteries or put in contact with PC boards which contain batteries.

Troubleshooting

Error Messages

If a problem occurs during luminaire calibration, at the end of the calibration sequence the Menu Display will cycle through any applicable error message(s) until the end of the list is reached. To review the error messages again, it will be necessary to access them using the Status function.

To access error messages:

Step 1. Press [MODE/ESC].

Step 2. Press     arrows until Fixture appears. Press .





Step 3. Press     arrows to access Status. Press . (Display will now scroll through any error messages or display OK if no errors.)

Table A-1: Error Messages

Display	Message
No Errors	No Errors Found
NO Sensor On Pan	Pan sensor not found,P n ReCalibrate fail.
NO Sensor On Tilt	Tilt sensor not found,Til ReCalibrate fail.
NO Sensor On Cyan	Cyan sensor not fo nd,Cyan ReCalibrate fail.
NO Sensor On Magenta	Magenta senso not found,Magenta ReCalibrate fail.
NO Sensor On Yellow	Yellow sensor not found,Yellow ReCalibrate fail.
NO Sensor On CTO	CTO sens r not found,CTO ReCalibrate fail.
NO Sensor On Color Wheel1	Color Wheel1 sensor not found,Color Wheel1 ReCalibrate fail.
NO Sensor On Color Wheel2	Colo Wheel2 sensor not found,Color Wheel2 ReCalibrate fail.
NO Sensor On Edge	Edge sensor not found,Edge ReCalibrate fail.
NO Sensor On Zoom	Zoom sensor not found,Zoom ReCalibrate fail.
NO Sensor On BeamShaper	BeamShaper sensor not found,BeamShaper ReCalibrate fail.
NO Sensor On Beam Shaper R	BeamShaper Rotate sensor not found,BeamShaper Rotate ReCalibrate fail.
NO Sensor On Frost	Frost1 sensor not found,Frost1 ReCalibrate fail.
NO Sensor On Frost2	Frost2 sensor not found,Frost2 ReCalibrate fail.
NO Sensor On Frame 1A	Frame 1A sensor not found,Frame 1A ReCalibrate fail.
NO Sensor On Frame 2A	Frame 2A sensor not found,Frame 2A ReCalibrate fail.
NO Sensor On Frame 3A	Frame 3A sensor not found,Frame 3A ReCalibrate fail.
NO Sensor On Frame 4A	Frame 4A sensor not found,Frame 4A ReCalibrate fail.
NO Sensor On Frame 1B	Frame 1B sensor not found,Frame 1B ReCalibrate fail.
NO Sensor On Frame 2B	Frame 2B sensor not found,Frame 2B ReCalibrate fail.
NO Sensor On Frame 3B	Frame 3B sensor not found,Frame 3B ReCalibrate fail.
NO Sensor On Frame 4B	Frame 4B sensor not found,Frame 4B ReCalibrate fail.
NO Sensor On Frame Rot	Frame Rotate sensor not found,Frame Rotate ReCalibrate fail.
Temp Error	Temperature sensor error
7U_FanFault1	Head Fan1 error
7U_FanFault2	Head Fan2 error

Troubleshooting Guide

If a problem is suspected, first try recalibrating the luminaire to prompt an error message. The chart below provides possible causes and remedies for various error messages and/or symptoms.

www.carlosmendoza
m.mx

Routine Maintenance

LED Replacement



WARNING: Ensure that power is removed from luminaire when installing LED.



CAUTION: Wear cotton gloves or other covering while installing LED. Touching LED glass with bare fingers will leave oil and may cause the LED to explode or reduce LED life. If touched, use alcohol and cotton cloth to thoroughly clean glass portion of LED.

To replace LED:

Step1: Ensure power is removed from luminaire.

Step2: At rear of luminaire head, loosen four Crossed Slot screws.

Step3: take out the LED.

Step4: Position new LED with dimple side down.

Step5: Re-tighten four Crossed Slot screws.



Allow LED to cool
CAUTION: before servicing.



Do not touch LED or
CAUTION: reflector with bare fingers.

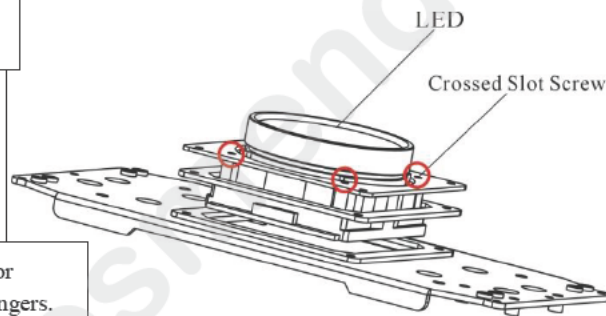

Figure A-1: Installing LED

Cleaning Optics and Filters



WARNING: Remove power from luminaire before performing maintenance.



WARNING: Acetone is a harsh cleaning agent and solvent. Acetone is very flammable. Please handle acetone according to manufacturer's safety instructions and precautions.

The front lens, optics filters, and reflector may require cleaning after extended use.

- **FRONT LENS:** Use a isopropyl alcohol with a soft, lint-free cloth to clean the front lens.
- **OPTICS/COLOR FILTERS:** Use Acetone or Isopropyl Alcohol along with a soft, lint-free cloth to clean the optics filters.
- **REFLECTOR:** Use Acetone or Isopropyl Alcohol along with a soft, lint-free cloth to clean the reflector.



CAUTION: Do not continuously rub color filters or reflector - it may damage or remove the optical coating.

Followspot Handle Accessory Installation (Optional)

The VLZ WASH Luminaire can be hung horizontally or vertically from any structure designed to work with the type of load created by this moving luminaire. Two mounting truss hooks or other mounting hardware are required. Many compatible truss hooks are available from different manufacturers for your particular needs. A minimum of two hooks per luminaire is required. If mounting method does not use truss hooks, two attachment points, per luminaire, are required.

Install mounting hardware and brackets:

Step 1. Install truss hooks on two provided truss hook brackets as required as shown in Figure A-5.

Step 2. Determine required configuration of bracket installation. Brackets may be installed in many different orientations as shown in Figure A-6.

Step 3. While pulling up on locking mechanism release, fit keyed holes onto raised mounting buttons at bottom of enclosure. Slide forward and release locking mechanism to lock in place. Ensure brackets are locked securely

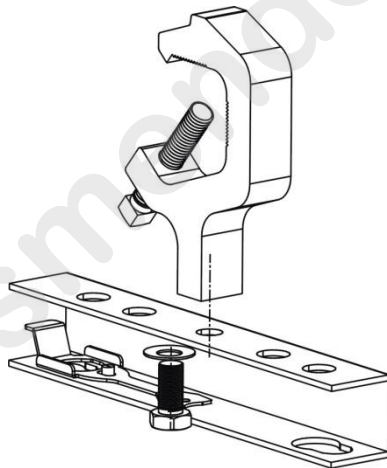
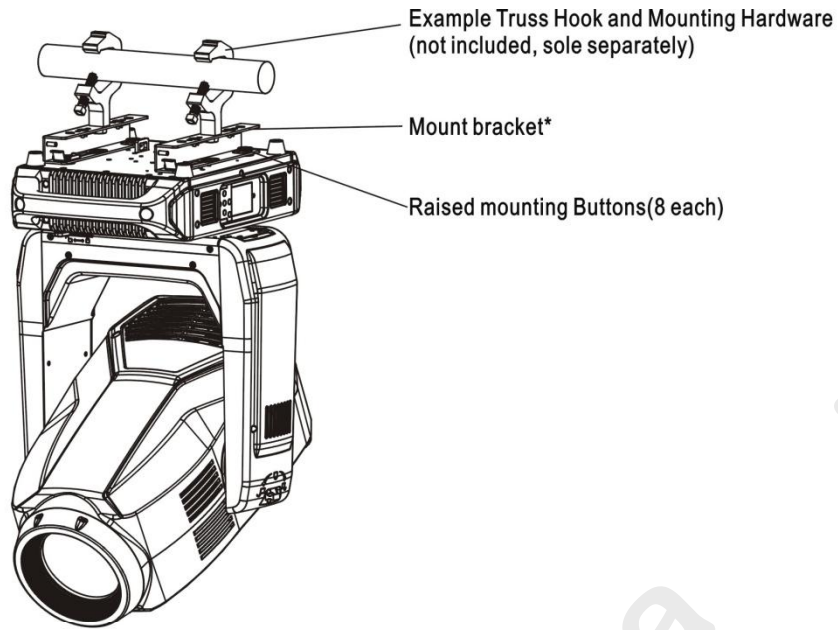

Figure A-5: Truss Hook Installation



WARNING Ensure that the bracket locking mechanism is fully seated after the bracket is installed on the luminaire.

AVERTISSEMENT: Assurez-vous que le mécanisme de support de verrouillage est complètement inséré après le support est installé sur l'appareil.



Fit bracket's keyed hole and locking mechanism over raised mounting buttons and slide forward.

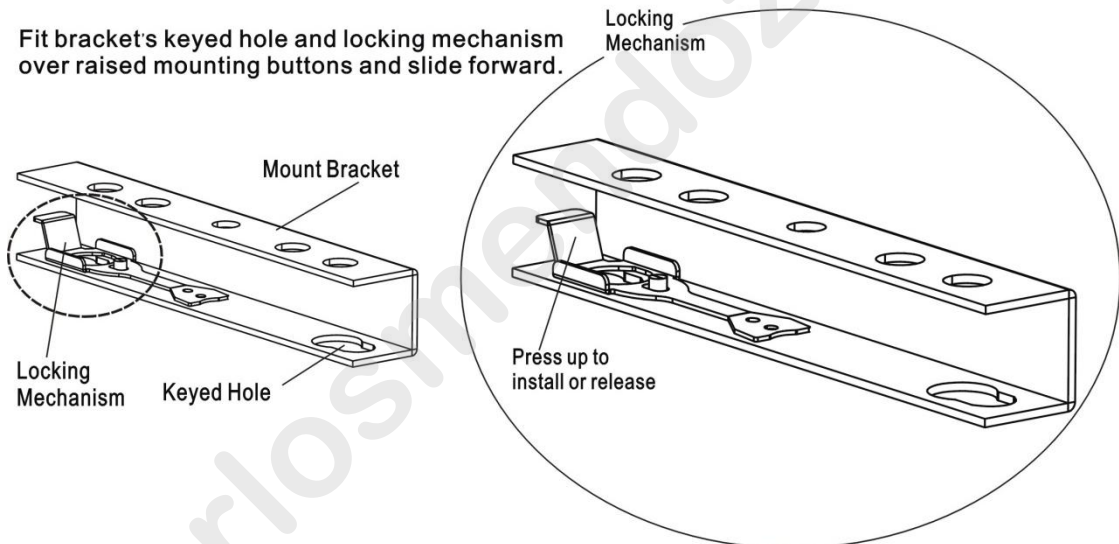
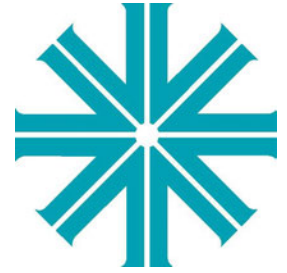

Figure A-6: Installing Brackets on Luminaire Enclosure

Notes

APPENDIX B



Technical Specifications



VLZ WASH Luminaire

PROGRAMMABLE FUNCTIONS

Color System

Six color control wheels total. A three filter CMY cross fading system, two fixed color wheels, and a variable CTO color temperature correction wheel.

Zoom Optics

Covering a range from 8.5° to 52° in Beam, 12.6° to 54° in Wash.

Strobe

High-performance dual blade strobe system capable of ultra-fast operation.

Edge and Pattern Focus

Variable beam focus to soften edges of gobo or spots. Remarkable depth of field capability allow morphing effects between all pattern and effects wheels.

Variable Frost

Independent, drop-in armature that holds variable frost glass.

Pan and Tilt

Movement and Speed.

Pan and Tilt Range

Pan - 540°, Tilt - 270°





OPTICAL

Source

Color Temperature

7400K

Output

Standard Mode:20319 lumens

Studio Mode:13941lumens



OPERATIONAL

Power Requirements

Standard AC power distribution from 100-240 VAC, 50/60 Hz. The unit requires up to 15 A depending on the AC supply voltage.

Control

Compatible with a wide variety of DMX512 consoles.

DMX Channels

52

Mounting Position:

The VLZ WASH luminaire can be mounted and operated in any orientation.

Weight

39kg

Dimensions

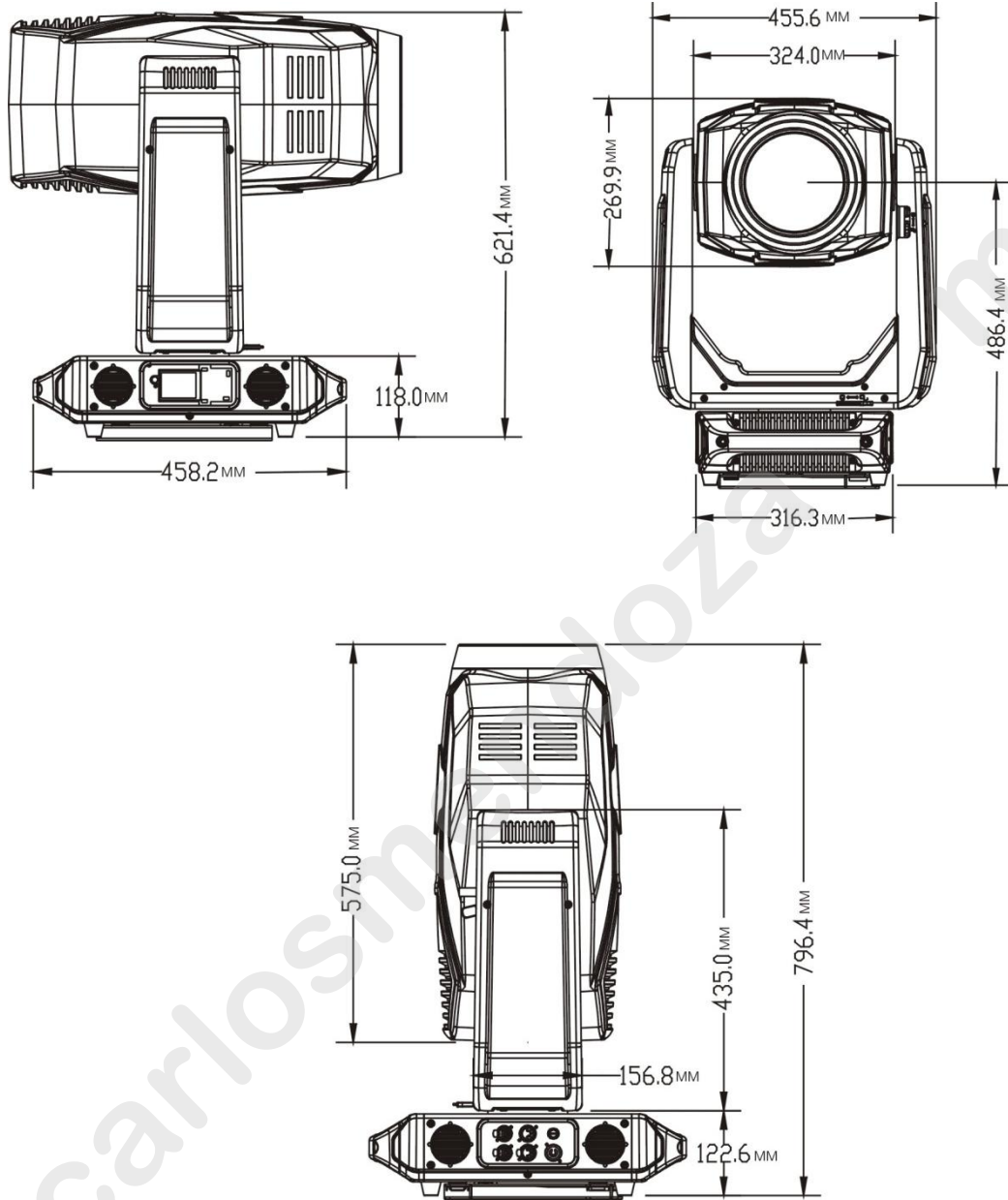

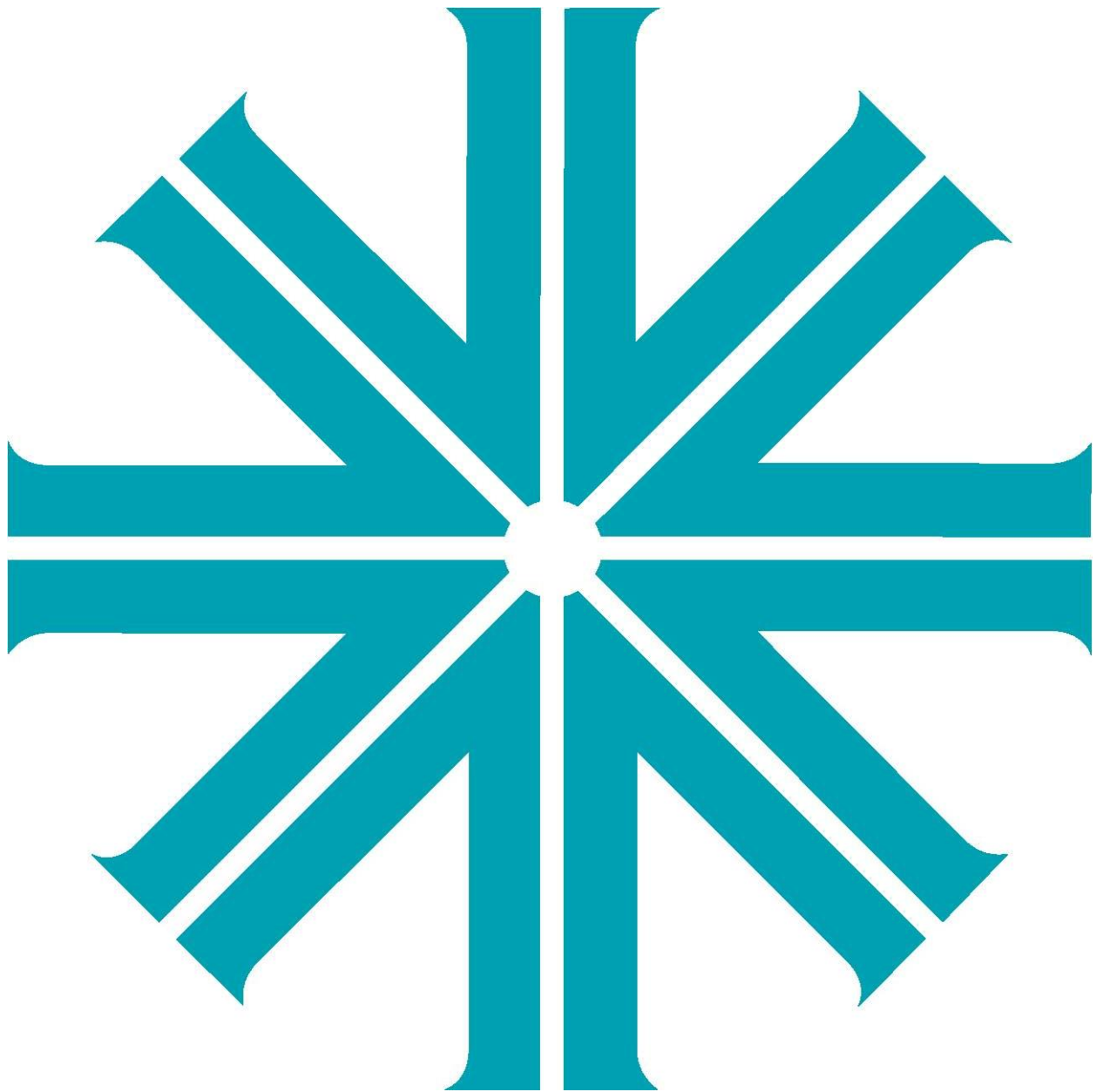

VARI*LITE
Express yourself.