

**PHILIPS**

**VARI\*LITE®**

***VL3500™ Wash &  
VL3500™ Wash FX Luminaires***



***USER'S MANUAL***

**VARI\*LITE**<sup>®</sup> is a trademark owned by Genlyte Thomas Group LLC and is registered in the United States and other countries.

**VL500**<sup>™</sup>, **VL1000**<sup>™</sup>, **VL2000**<sup>™</sup>, **VL2201**<sup>™</sup>, **VL2202**<sup>™</sup>, **VL2400**<sup>™</sup> (and the individual product designations), **VL3000**<sup>™</sup>, **VL3500**<sup>™</sup>, **Series 500**<sup>™</sup>, **Series 1000**<sup>™</sup>, **Series 2000**<sup>™</sup>, **Series 3000**<sup>™</sup>, **DICHR0\*TUNE**<sup>™</sup>, **VARI\*IMAGE**<sup>™</sup>, **VARI\*BRITE**<sup>™</sup>, and the Vari-Lite Asterisk are also trademarks owned by Genlyte Thomas Group LLC.

**VARI\*LITE**<sup>®</sup> products are protected by one or more of the following patents, and other pending patent applications worldwide:

U. S. Patents No. 6,809,869; 6,796,682; 6,769,792; 6,578,987; 6,550,939; 6,282,027; 6,123,436; 6,113,252; 6,046,861; 6,031,749; 6,011,640; 5,969,868; 5,959,768; 5,934,794; 5,882,107; 5,829,868; 5,825,548; 5,798,619; 5,774,273; 5,769,527; 5,758,956; 5,728,994; 5,640,061; 5,590,954; 5,454,477; 5,432,691; 5,367,444; 5,329,431; 5,307,295; 5,282,121; 5,278,742; 5,209,560; 5,186,536; 5,073,847; 5,010,459; 4,980,806; 4,972,306; 4,800,474; 4,771,176; 4,701,833; 4,602,321;

U. S. Design Patents No. 524,245; 457,678; 452,339; 451,890; 442,944; 439,356; 420,332; 417,300; 415,301; 414,888; 413,995; 377,338; 366,712; 359,574; 350,408; 347,113;

Australia Patents No. 693,691; 683,695; 667,109; 649,264; 646,588; 586,095; 576,400;

Australia Design Patents No. 128,796; 128,795;

Canada Patents No. 2,070,670; 2,050,375; 1,270,675; 1,259,058;

Canada Design Patents No. 81,234; 81,233; 76,046;

European (UK) Patents No. 0 652 400; 0 586 049; 0 565 218; 0 547 732; 0 534 710; 0 495 305; 0 474 202; 0 379 970; 0 253 082; 0 253 081; 0 248 974; 0 192 882;

Germany Patents No. 694 25 943.8; 693 14 122.0; 692 08 615.3; 692 07 692.1; 691 31 478.0; 691 21 029; 6 0 33 385.4; 37 89 166.9; 37 68 727.1; 37 51 804.6; 37 50 201.8; 35 87 270.5;

Germany Design Patents No. M 98 01 745.4; M 96 04 515.9; M 96 04 514.0; M 94 07 689; M 9 02 9 1.2; M 499 03 583.6; M 498 11 203.9; G 93 12 884.3;

Spain Patents No. 2 090 191; 2 084 289; 2 020 960; 0 548 328;

Spain Utility Model Patent No. 2.031.748;

Spain Design Patents No. 0.137.502; 0.137.501; 0.133.573;

Greece Patent No. 910.400.544;

Japan Patents No. 2,843,696; 2,059,669; 2,055,324; 2,002,168; 1,966,525; 1,889,81; 1,792,721; 1,770,241;

Japan Design Patents No. 985,985-1; 985,985; 947,552; 945,436-1; 9 5 436; 1,106,089; 1,077,598; 1,072,598; 1,060,414; 1,002,123;

Korea Patents No. 76,310; 42,639; 283,770; 181,180;

Korea Design Patents No. 209,896; 209,895;

Mexico Patent No. 180,148;

Taiwan Patents No. 78,726; 66,975; 65,380; 28,275;

United Kingdom Design Registrations No. 2082 26; 20 2562; 2056387; 2056386; 2042174; 2038212; 2033108; 2029499.

All other brand or product names which may be mentioned in this manual are trademarks or registered trademarks of their respective companies or organizations.

The information furnished in this manual is for informational use only and is subject to change without notice. Please check [www.vari-lite.com](http://www.vari-lite.com) for latest version. Vari-Lite assumes no responsibility or liability for any errors or inaccuracies that may appear in this manual. All information and graphics are property of Vari-Lite, a Philips group company, 10911 Petal Street Dallas, Texas 75238 USA.

Version as of: **June 2009**

Part number **02 9686.0001 B**

## How To Obtain Warranty Service

A copy of the Vari-Lite Limited Warranty was included in the shipping package for this VARI\*LITE® product.

To obtain warranty service, please contact customer service at 1-877-VARI-LITE (1-877-827-4548), +1-214-647-7880, or [customerservice@genlytecontrols.com](mailto:customerservice@genlytecontrols.com) and request a Return Material Authorization (RMA) for warranty service. You will need to provide the model and serial number of the item being returned, a description of the problem or failure and the name of the registered user or organization. If available, you should have your sales invoice to establish the date of sale at the beginning of the warranty period.

Once you obtain the RMA, pack the unit in a secure shipping container or in its original packing box. Go to the Vari-Lite web site [www.vari-lite.com](http://www.vari-lite.com), click on the Support link, and download the RMA form. Put the completed RMA form in shipping container along with a copy of your invoice (if available). Write the RMA number legibly on or near the shipping address label and return the unit, freight prepaid to:

**Vari-Lite**  
**Attention: Warranty Service (RMA# \_\_\_\_\_)**  
**10911 Petal Street**  
**Dallas, Texas 75238 USA**

As stated in the warranty, it is required that the shipment be insured and FOB our service center.

## Compliance Notice

**FCC** This equipment has been tested and found to comply with the limits for a Class A digital device pursuant to Part 15 of FCC Rules. These limits are designed to provide reasonable protection against harmful interference when this equipment is operated in a commercial environment. This equipment generates, uses, and can radiate radio frequency energy and, if not installed and used in accordance with Vari-Lite system, service, and safety guidelines, may cause harmful interference to radio communications. Operation of this equipment in a residential area is likely to cause harmful interference, in which case the user will be required to correct the interference at his/her own expense.

### **CE Declaration of Conformity**

We declare, under our sole responsibility, that this product complies with the relevant clauses of the following standards and harmonized documents:

#### **Safety**

EN 60598-1:2000 Luminaire Safety Standard, General Requirements

EN 60598-2-17:1989/A2: 1991 Specification for Luminaire for Stage and Studio Lighting

#### **EMC**

EN 61000-6-4:2001 Emission Standard for industrial environments

EN 61000-6-2:2001 Immunity for industrial environments

We certify that the product conforms to the protection requirements of council directives: 73/23/EEC (LVD) and 89/336/EEC (EMC)

## Safety Notice

It is extremely important to read ALL safety information and instructions provided in this manual and any accompanying documentation before installing and operating the products described herein. Heed all cautions and warnings during installation and use of this product.

Safety symbols used throughout this manual are as follows:



**CAUTION** advising of potential damage to product.



**WARNING** advising of potential injury or death to persons.

GENERAL INFORMATION PERTAINING TO PROTECTION AGAINST ELECTRICAL SHOCK, FIRE, EXPOSURE TO EXCESSIVE UV RADIATION, AND INJURY TO PERSONS CAN BE FOUND BELOW.

### **WARNING:**

#### **INSTRUCTIONS FOR CONTINUED PROTECTION AGAINST FIRE**

1. The VARI\*LITE® VL3500™ Wash and VL3500™ Wash FX Luminaires have been designed for use with specific lamp types. The following lamps are approved for use: Osram SharXS® HTI® 1500 W/D7/60 metal halide lamp (included with luminaires), Philips / MSR 1510 Gold™ SA/DE Lamp, or GE CSR 1500/S/DE/60 96800 Lamp. Installing any other lamp types can be hazardous. Dispose of used lamps properly.



**Note:** Users can check the latest version of Vari-Lite Technical Notice TN-248, on the Vari-Lite web site, for all approved lamps. Installing another type of lamp, other than as specified herein, may be hazardous.

2. Luminaires may be mounted on any type of surface as long as mounting instructions are followed. See instructions detailed in this manual.
3. Note distance requirement from combustible materials or illuminated objects for VARI\*LITE® luminaire.

### **WARNING:**

#### **INSTRUCTIONS FOR CONTINUED PROTECTION AGAINST ELECTRICAL SHOCK**

1. VARI\*LITE® luminaires are designed for dry locations only. Exposure to rain or moisture may damage luminaire.
2. Disconnect power before servicing any VARI\*LITE® equipment.
3. Servicing to be performed by qualified personnel only.

**WARNING:**

**INSTRUCTIONS FOR CONTINUED PROTECTION AGAINST EXCESSIVE EXPOSURE TO UV RADIATION**

1. Many VARI\*LITE® luminaires use a lamp that produces UV radiation. DO NOT look directly at lamp.
2. It is hazardous to operate luminaires without lens or shield. Shields, lenses, or ultraviolet sensors shall be changed if they have become visibly damaged to such an extent that their effectiveness is impaired. For example, by cracks or deep scratches.

**WARNING:**

**INSTRUCTIONS FOR PROTECTION AGAINST INJURY TO PERSONS**

1. Exterior surfaces of the luminaire will be hot during operation. Use appropriate safety equipment (gloves, eye protection, etc.) when handling and adjusting hot equipment and components.
2. Luminaires will have a hot lamp when operating. Disconnect power and allow lamp to cool before replacing.
3. Arc lamps emit ultraviolet radiation which can cause serious skin burn and eye inflammation. Additionally, arc lamps operate under high pressure at very high temperatures. Should the lamp break, there can exist a danger of personal injury and/or fire from broken lamp particles being discharged.
4. Wear eye protection when relamping.
5. Appropriate safety equipment (gloves, eye protection) should be used when handling damaged lamps.
6. If lamp is touched with bare hands, clean lamp with denatured alcohol and wipe with lint-free cloth before installing or powering up the luminaire.
7. The lamp shall be changed if it has become damaged or thermally deformed.

**WARNING:**

**RF INTERFERENCE**

1. This is a Class A product. In domestic environment this product may cause radio interference, in which case, the user may be required to take adequate measures.

**ARC LAMP CHARACTERISTIC CONSIDERATIONS**

1. Arc lamps require a period of time to relight after a power interruption or a severe voltage dip. In some cases lamp will automatically relight after it has cooled depending on Lamp Power-Up State configuration setting.
2. Burning position is Universal.

## Sicherheitshinweise

Es ist äußerst wichtig, ALLE Sicherheitsinformationen und -hinweise in diesem Handbuch und dem beiliegenden Informationsmaterial zu lesen, bevor Sie die hierin beschriebenen Produkte installieren bzw. bedienen. Halten Sie bei der Installation und dem Einsatz dieses Produkts alle Warnhinweise und Vorsichtsmaßnahmen ein.

Folgende Sicherheitssymbole werden in diesem Handbuch verwendet:



**VORSICHT** - weist auf möglichen Produktschaden hin.



**WARNUNG** - weist auf mögliche Körperverletzung und Lebensbedrohung hin.

NACHSTEHEND FINDEN SIE ALLGEMEINE HINWEISE ÜBER SICHERHEITSVORKEHRUNGEN GEGEN ELEKTROSCHOCK, FEUER, ÜBERHÖHTE UV-STRAHLUNG UND KÖRPERVERLETZUNGEN.

### **WARNUNG:**

#### **HINWEISE ZUM FEUERSCHUTZ**

1. VARI\*LITE®-Scheinwerfer sind ausschließlich für den Einsatz mit bestimmten Lampentyps. Achten Sie auf den Lampentyp (Osram SharXS® HTI® 1500 W/D7/60 metal halide lamp), bevor Sie die jeweiligen Lampen ersetzen. Die Installation eines anderen Lampentyps kann gefährlich sein.
2. Scheinwerfer können auf jeder beliebigen Oberfläche montiert werden, solange Sie die Montageanweisungen befolgen. Detaillierte Hinweise finden Sie in diesem Handbuch.
3. Beachten Sie die Einhaltung des erforderlichen Sicherheitsabstandes der VARI\*LITE®-Scheinwerfer von brennbarem Material oder beleuchteten Objekten.

### **WARNUNG:**

#### **HINWEISE ZUM SCHUTZ GEGEN ELEKTROSCHOCK**

1. VARI\*LITE®-Scheinwerfer eignen sich ausschließlich für trockene Standorte. Regen oder Feuchtigkeit können die Scheinwerfer beschädigen.
2. Unterbrechen Sie die Stromzufuhr, bevor Sie mit der Arbeit an VARI\*LITE®-Geräten beginnen.
3. Die Geräte sollten nur von qualifiziertem Personal gewartet werden.

**WARNUNG:**

**HINWEISE ZUM SCHUTZ GEGEN ÜBERHÖHTE UV-STRAHLUNG**

1. Viele VARI\*LITE®-Scheinwerfer verwenden die Lampentyp, der UV-Strahlen abgibt. SCHAUEN SIE NICHT direkt in die Lampe.
2. Es ist gefährlich, Leuchten ohne Linsen oder Blenden zu bedienen. Blenden, Linsen oder Ultraviolettscirme müssen ausgetauscht werden, sofern deren Schutzwirkung durch sichtbare Beschädigung (z. B. Sprünge oder Schrammen) eingeschränkt ist.

**WARNUNG:**

**HINWEISE ZUM SCHUTZ GEGEN KÖRPERVERLETZUNGEN**

1. Bei Betrieb sind die Außenflächen der Scheinwerfer heiß. Verwenden Sie bei der Bedienung von aufgeheizter Apparatur die jeweils geeignete Sicherheitsausrüstung (Handschuhe Augenschutz etc.).
2. Bei Betrieb der Scheinwerfer ist die Lampe heiß. Unterbrechen Sie die Stromzufuhr und lassen Sie die Lampe abkühlen, wenn Sie diese austauschen.
3. Bogenlampen senden ultraviolette Strahlen aus, die Hautverbrennungen und Augenentzündungen verursachen können. Der Betrieb von Bogenlampen erfolgt unter Hochdruck und bei hohen Temperaturen. Sollte die Lampe zerbrechen, besteht die Gefahr von Körperverletzung bzw. von Feuer, das von Lampenteilen ausgelöst werden kann.
4. Tragen Sie beim Austausch der Lampen einen Augenschutz.
5. Die geeignete Sicherheitsausrüstung (Handschuhe, Augenschutz) sollte beim Umgang mit beschädigten Lampen verwendet werden.
6. Wenn die Lampe mit bloßen Händen berührt wird, reinigen Sie sie mit denaturiertem Alkohol und einem fusenfreien Tuch, bevor Sie die Scheinwerfer installieren oder in Betrieb nehmen.
7. Wenn die Lampe beschädigt oder durch Hitzeeinwirkung deformiert ist, muß diese ausgetauscht werden.

**WARNUNG:**

**HF-INTERFERENZ**

1. Es handelt sich um ein Produkt der Klasse A. In einer Wohnumgebung kann das Produkt Hochfrequenzstörungen verursachen. In diesem Fall müssen eventuell geeignete Maßnahmen getroffen werden.

**BESONDERHEITEN VON BOGENLAMPEN**

1. Bogenlampen benötigen eine gewisse Zeitdauer, um nach einem Stromausfall oder einem Spannungsfälle wieder aufzuleuchten. In einigen Fällen wird die Lampe nach Abkühlung automatisch wieder aufleuchten, je nach der Systemkonfigurationseinstellung des Lampeneinschaltungsstatus.
2. Die Brennposition ist Universal.



## Notes de sécurité

Avant de procéder à l'installation des produits décrits dans ce guide et de les mettre en marche, il est extrêmement important de lire TOUS les renseignements et TOUTES les directives de sécurité contenues dans ce guide ainsi que toute documentation jointe. Tenir compte de tous les avertissements et suivre toutes les précautions pendant l'installation et l'utilisation de cet appareil.

Les symboles de sécurité utilisés dans ce guide sont les suivants :



**ATTENTION** Ce symbole annonce que l'appareil risque d'être endommagé.



**AVERTISSEMENT** Ce symbole annonce qu'il y a risque d'accident grave ou même fatal.

CETTE SECTION CONTIENT DES INFORMATIONS GÉNÉRALES POUR SE PROTÉGER CONTRE LES DÉCHARGES ÉLECTRIQUES, LES INCENDIES, L'EXPOSITION EXCESSIVE AUX RAYONS UV ET TOUT AUTRE ACCIDENT POUVANT ENTRAÎNER DES BLESSURES.

### AVERTISSEMENT:

#### DIRECTIVES POUR SE PROTÉGER CONTRE LES INCENDIES

1. Les luminaires VARI\*LITE® ont été conçus pour être utilisés uniquement avec certaines type de lampes. Vérifier le type de lampe (Osram SharXS® HTI® 1500 W/D7/60 metal halide lamp) avant de remplacer les lampes. L'installation d'un autre type de lampe peut poser un danger.
2. Les luminaires peuvent être fixés sur tout type de surface tant que les directives de montage sont respectées. Voir les explications détaillées dans ce guide.
3. Vérifier la distance à respecter entre les matériaux combustibles ou les objets illuminés et les luminaires VARI\*LITE®

### AVERTISSEMENT:

#### DIRECTIVES POUR SE PROTÉGER CONTRE LES DÉCHARGES ÉLECTRIQUES

1. Les luminaires VARI\*LITE® sont conçus pour une utilisation au sec uniquement. Une exposition à la pluie et à l'humidité risque d'endommager le luminaire.
2. Débrancher l'appareil avant de procéder à la révision de tout matériel VARI\*LITE®.
3. Les révisions doivent être effectuées uniquement par des personnes qualifiées.

**AVERTISSEMENT:**

**DIRECTIVES POUR SE PROTÉGER CONTRE UNE EXPOSITION EXCESSIVE AUX RAYONS UV**

1. Plusieurs luminaires VARI\*LITE® utilisent une lampe qui produit des rayons UV. NE PAS fixer son regard sur la lampe.
2. L'utilisation des luminaires sans lentille ou blindage pose des risques. Tous blindages, lentilles ou écrans ultraviolet visiblement endommagés au point que leur efficacité en est affectée doivent être remplacés, par exemple s'il y a des fissures ou de profondes rayures.

**AVERTISSEMENT:**

**DIRECTIVES POUR SE PROTÉGER CONTRE LES ACCIDENTS POUVANT ENTRAÎNER DES BLESSURES**

1. Les surfaces externes du luminaire deviennent brûlantes quand l'appareil est en marche. Pour manœuvrer ou ajuster des appareils brûlants et leurs composants, se protéger suffisamment (gants, protection pour les yeux, etc.).
2. La lampe du luminaire est brûlante lorsqu'il est en marche. Débrancher le courant et attendre que la lampe ait refroidi avant de la remplacer.
3. Les lampes à arc émettent des rayons ultraviolets pouvant causer de graves brûlures sur la peau et une inflammation des yeux. De plus, les lampes à arc fonctionnent sous haute tension à de très hautes températures. Si la lampe se casse, les fragments de la lampe cassée peuvent causer blessures et/ou incendie en s'éparpillant.
4. Se protéger les yeux pour remplacer la lampe.
5. Utiliser des appareils de protection appropriés (gants, protection des yeux) pour manier des lampes endommagées.
6. Si la lampe a été touchée avec des mains nues, la nettoyer avec de l'alcool dénaturé et l'essuyer avec un chiffon non-pelucheux avant d'installer ou de brancher le luminaire.
7. Si la lampe a été endommagée ou a reçu une déformation thermique, elle doit être remplacée.

**AVERTISSEMENT:**

**INTERFÉRENCE RF**

1. Cet appareil est de Classe A. Dans un environnement domestique, cet appareil peut causer des interférences radio et si c'est le cas, l'utilisateur peut avoir à prendre des mesures adéquates.

**CONSIDÉRATIONS DES CARACTÉRISTIQUES DE LAMPES À ARC**

1. Après une interruption de courant ou une baisse importante de voltage, les lampes à arc mettent du temps avant de se rallumer. Dans certains cas, la lampe se rallumera automatiquement après s'être refroidie. Cela dépend de la manière dont le système est réglé pour le statut de mise en marche de la lampe.
2. La position Brûler est Universelle.

## Aviso sobre Seguridad

Es muy importante leer TODA la información e instrucciones sobre seguridad que se indica en este manual así como en los documentos adjuntos antes de instalar y operar los productos descritos. Se debe prestar atención a todos los avisos y advertencias durante la instalación y uso de este producto.

Los símbolos de seguridad usados en este manual son los siguientes:



**CUIDADO**, indica posibles daños al producto.



**ADVERTENCIA**, indica posibles lesiones o muerte a las personas.

LA INFORMACIÓN GENERAL RELACIONADA A LA PROTECCIÓN CONTRAGOLPES DE CORRIENTE ELÉCTRICA, INCENDIO, EXPOSICIÓN EXCELSIVA A RADIACIÓN ULTRAVIOLETA Y LESIONES A LAS PERSONAS SE PUEDE ENCONTRAR SEGUIDAMENTE:

### **ADVERTENCIA:**

#### **INSTRUCCIONES PARA PROTECCIÓN CONTINUA CONTRA INCENDIO**

1. Las luminarias VARI\*LITE® han sido diseñadas para ser usadas solamente con algunas lámparas. Tome nota del tipo de lámpara (Osram SharXS® HTI® 1500 W/D7/60 metal halide lamp) antes de reemplazarla. Instalación de otro tipo de lámpara puede ser peligroso.
2. Las luminarias se pueden instalar en cualquier tipo de superficie siempre que se sigan las instrucciones de instalación. Vea las instrucciones detalladas en este manual.
3. Tome nota de los requerimientos de distancia de materiales combustibles u objetos iluminados para las luminarias VARI\*LITE®.

### **ADVERTENCIA:**

#### **INSTRUCCIONES PARA PROTECCIÓN CONTINUA CONTRA CHOQUE ELÉCTRICO**

1. Las luminarias VARI\*LITE® están diseñadas solamente para lugares secos. La exposición a la lluvia o humedad pueden dañar la luminaria.
2. Desconecte la energía antes de dar servicio a cualquier equipo de VARI\*LITE®.
3. El servicio debe ser realizado solamente por personal calificado.

**ADVERTENCIA:**

**INSTRUCCIONES PARA PROTECCIÓN CONTINUA CONTRA LA EXPOSICIÓN EXCESIVA DE RADIACIÓN ULTRA VIOLETA**

1. Muchas luminarias VARI\*LITE® usan un tipo de lámpara que produce radiación UV. NO mire directamente a la lámpara.
2. Es peligroso operar luminarias sin lentes o protectores. Debe cambiar los protectores, lentes o pantallas ultravioletas si se aprecia que han sido dañadas, y que su efectividad pudiera estar deteriorada. Por ejemplo, si tuvieran rajaduras o raspaduras profundas.

**ADVERTENCIA:**

**INSTRUCCIONES PARA PROTECCIÓN CONTRA LESIONES DE PERSONAS**

1. Las superficies exteriores de las luminarias están calientes durante su operación. Use un equipo de seguridad apropiado (guantes, protección para los ojos, etc.) cuando haga ajustes en el equipo y componentes que están calientes.
2. Cuando las luminarias están en operación la lámpara estará muy caliente. Desconecte la energía y deje que la lámpara se enfríe antes de reemplazarla.
3. Las lámparas de arco emiten radiaciones ultravioletas que pueden ocasionar serias quemaduras a la piel e inflamación a los ojos. Además, las lámparas de arco operan a alta presión y muy alta temperatura. Si la lámpara se rompe, puede existir el peligro de lesiones al personal o un incendio ocasionado por las partículas de la lámpara rota que se caen.
4. Use protección para los ojos cuando vuelve a colocar una lámpara nueva.
5. Use un equipo de seguridad apropiado (guantes, protección para los ojos, etc.) cuando trabaje con lámparas dañadas.
6. Si toca la lámpara con las manos, limpie la lámpara con alcohol desnaturalizado y con tela sin pelusas antes de instalar o volver a conectar la luminaria.
7. Cambie la lámpara si está dañada o deformada térmicamente.

**ADVERTENCIA:**

**INTERFERENCIA RF**

1. Este es un producto de Clase A. En el ambiente de la casa este producto puede ocasionar radiointerferencia, en cuyo caso, el usuario debe tomar las medidas adecuadas.

**CONSIDERACIONES SOBRE LAS CARACTERÍSTICAS DE LA LÁMPARA DE ARCO**

1. Las lámparas de arco requieren un período de tiempo para volver a iluminarse después de una interrupción de energía o de una severa caída de voltaje. En algunos casos, la lámpara se volverá a iluminar de forma automática después que se ha enfriado dependiendo de la configuración del sistema de energía de la lámpara.
2. La posición de encendido es universal.

## 安全性に関する注意事項

ここに記載されている製品を取り扱う場合は、まず本マニュアルおよび付属のマニュアルの安全性に関する情報と説明をすべてお読みください。また、実際に本製品を取り付けたり使用する際には、すべての注意事項および警告に留意して作業してください。

本マニュアルでは、以下の安全マークを使用しています。



注意：製品に損傷を与える危険性があります。



警告：人身事故につながる危険性があります。

感電、火災、UV放射に対する過度の露出、および人身事故を防ぐための一般的な情報については、以下の説明をお読みください。

警告：

火災の発生を防ぐためのヒント

1. VARI\*LITE® 照明器具は、ランプを使用するように設計されています。ランプを交換する際は、ランプの種類（など）を確認するようにしてください。他の種類のランプを取り付けると危険です。
2. 照明器具は、本マニュアルの指示に従って操作するかぎり、どのようなタイプの表面にでも取り付けることができます。詳細については、本マニュアルを参照してください。
3. ヒューズを交換する場合は、同じヒューズ（同じ種類、同じクラス）を使用してください。
4. VARI\*LITE® 照明器具は、可燃性物質または他の光源から必要な距離だけ離して配置してください。

警告：

感電を防ぐためのヒント

1. VARI\*LITE® 照明器具は、乾燥した環境で使用するように設計されています。雨で濡れる場所や湿気の多い場所に取り付けると、照明器具が傷むことがあります。
2. VARI\*LITE® 照明器具を修理点検する場合は、必ず先に電源を切ってください。
3. 照明器具の修理点検は、資格を持つ技師のみが行うようにしてください。

**警告：**

過度の UV 放射にさらされないためのヒント

1. VARI\*LITE® 照明器具の多くは、UV 放射を生ずる HID タイプのランプを使用しています。ランプを直視することは避けてください。
2. レンズまたはシールドを使わずに照明器具を点灯すると危険です。レンズ、シールド、紫外線画面は、ひび割れや深い引っかき傷などにより、その効力が損なわれるようになったら取り替えるようにします。

**警告：**

人身事故を防ぐためのヒント

1. 照明器具が点灯しているときは、その外側が熱くなります。熱くなった器具やコンポーネントを取り扱う際には、適切な防具（手袋や保護用眼鏡）を使用してください。
2. 照明器具が点灯しているときは、そのランプが熱くなります。ランプを交換する場合は、照明器具の電源を切り、ランプの温度が下がるまで待ってください。ランプの裏ぶたをあけると、遮断スイッチが働いて、ランプの電源が切れる場合があります。
3. アーク灯は紫外線を放射します。この紫外線によって、ひどい火傷を負ったり、目の炎症を起こすことがあります。さらに、アーク灯は、高圧高温の状態で光を発します。そのため、万一アーク灯が破損すると、飛び散った破片で人身事故や火災が発生する危険性があります。
4. 再点灯するときには、保護用眼鏡を着用してください。
5. 損傷したランプを取り扱う場合は、適切な防具（手袋や保護用眼鏡）を着用してください。
6. 手袋を着用せずに直接手でランプを触った場合は、変性アルコールを使ってランプをきれいにし、糸くずの出ない布で拭いてから照明器具を取り付け、電源を入れるようにします。
7. 傷がついたランプや熱によって変形したランプは取り替えてください。

**警告：**

**RF 干渉**

1. 本製品は Class A に分類されます。本製品は、家庭環境において無線干渉を起こす可能性があります。その場合、使用者は適切な処置を取らなければならないことがあります。

**アーク灯の特性**

1. 停電後または大きな電圧ディップ後にアーク灯を再点灯する場合は、しばらく時間をおくようにしてください。Lamp Power-Up State) システム設定によっては、温度が下がったときに自動的に再点灯される場合もあります。
2. アーク灯は点光源です。

# Table of Contents

## Introduction

About This Manual .....	1
Additional Documentation .....	1
Text Conventions .....	2
Customer Service .....	2

## Chapter 1. Description

### Features

Features List .....	4
---------------------	---

### Components

Included Items: VL3500 Wash Luminaire .....	5
Included Items: VL3500 Wash FX Luminaire .....	6
Replacement Items/Accessories .....	7
Luminaire Overview .....	8

## Chapter 2. Installation

### Power and Data Cabling Requirements

Power .....	10
Data Cables .....	11
Recommended Cable Types/Manufacturers .....	12
Male Termination Connector .....	12

### Warnings and Cautions

Exceptional Safety Information for the VL3500 Wash .....	13
--	----

### Installation Procedures

Hanging the Luminaire .....	14
Floor Mounting the Luminaire .....	18
Connecting Data and Power .....	18

### Powering Up

Power Up and Configuration Procedure .....	19
--	----

### Addressing

Program Starting Address .....	20
Program Starting Address Without Calibrating Luminaire .....	20

### Powering Down and Packing Up

Pack-Up Cues for Shipping: VL3500™ Wash Luminaire .....	21
Pack-Up Cues for Shipping: VL3500™ Wash FX Luminaire .....	22
Packing for Transportation and Shipment .....	23

## Chapter 3. Operation

### DMX Operation

Channel Mapping: VL3500™ Wash Luminaire .....	26
Channel Mapping: VL3500™ Wash FX Luminaire .....	28
Control Channel Functions .....	31

### DMX Mapping

Color Control .....	33
Color Mixing .....	33
Fixed Color Wheel 1 .....	33
Fixed Color Wheel 2 .....	34
Beam Control .....	35
Strobe .....	35
Aperture .....	35
FX Pattern Wheel (VL3500 Wash FX Only) .....	36
Index/Rotation .....	37

### Luminaire Timing

Timing Channel Information .....	38
----------------------------------	----

### Updating Software

USB Download .....	46
Transferring Software From Luminaire to Luminaire .....	47

## Chapter 4. Menu System

### Menu Operation

What Is the Menu System? .....	50
Controls Operation .....	50
Default State .....	51
Shortcuts .....	51

### Menu Functions

Menu System Overview .....	52
Menu System Function Chart .....	53
Menu Function Definitions .....	56

### Self-Tests

Running Parameter Tests .....	59
-------------------------------	----

## Appendix A. Troubleshooting and Maintenance

### Troubleshooting

Error Messages .....	62
----------------------	----

### Routine Maintenance

Lamp Replacement .....	63
Align Lamp .....	64
Internal Lens Replacement .....	65
Front Lens Assembly Removal .....	67



Color Filter Replacement ..... 69  
FX Pattern Replacement (VL3500 Wash FX Only) ..... 71  
Cleaning Front Lens ..... 74

**Appendix B. Technical Specifications**

**Specifications**

VL3500 Wash and VL3500 Wash FX Luminaires ..... 76  
Photometric Data: VL3500 Wash Luminaire ..... 78  
Photometric Data: VL3500 Wash FX Luminaire ..... 79

www.carlosmendoza.com.mx

## Notes

[www.carlosmendoza.com.mx](http://www.carlosmendoza.com.mx)

# Introduction

---

## About This Manual

This manual provides necessary information regarding safety, installation, operation and routine maintenance for the VARI\*LITE® VL3500™ Wash Luminaire and the VL3500™ Wash FX Luminaire. Familiarizing yourself with this information will help you to get the most out of your luminaire.



**WARNING:** It is important to read ALL accompanying safety and installation instructions to avoid damage to the product and potential injury to yourself or others.

---

This manual covers the following models:

Model	Part Number	Source
VL3500™ Wash Luminaire	20.9686.001	Arc
VL3500™ Wash FX Luminaire	0 9686.0011	Arc

---

## Additional Documentation

A service manual for extended maintenance of the VL3500™ Wash and VL3500™ Wash FX luminaires is available in electronic (PDF) format for Authorized VARI\*LITE® Service Centers and Technicians. Please check the Vari Lite website for the most current manuals.

- VL3500™ Wash and VL3500™ Wash FX Luminaire Service Manual (02.9686.0010)



**CAUTION:** Performing maintenance procedures may void the product warranty. Refer to the Vari-Lite Limited Warranty card included in the product shipping package for more information.

---

For more information regarding DMX512 systems, refer to the following document available from United States Institute for Theatre Technology, Inc. (USITT):

- Digital Data Transmission Standard for Dimmers & Controllers plus AMX 192 Analog Multiplex Data Transmission Standard for Dimmers & Controllers. (A copy of Recommended Practice for DMX512 is included).

USITT Inc.  
 6443 Ridings Road  
 Syracuse, New York 13206-1111 USA  
 Tel: (800) 938-7488 Fax: (866) 398-7488 / [www.usitt.org](http://www.usitt.org)

---

## Text Conventions

The following styles and meanings are used throughout this manual:

Style	Meaning
[Button]	Front panel button. Example: Press [Menu].
[Up] / [Down] arrows	Press either [Up] or [Down] arrow button at Menu Display.
MENU	LCD Menu Display read-out. Example: Press [Up] / [Down] arrows until LAMP appears.

---

## Customer Service

### Our Goal

At Vari-Lite, we are committed to providing you the highest quality in customer service. Our comprehensive resources are available to help your business succeed and ensure you get the full benefit of being a Vari-Lite customer. Whether your needs are telephone troubleshooting assistance, product training or technical service, our full-time staff of experienced professionals are on-hand to provide support.

### How to Reach Us

For assistance in your area, call the dealer from which your product was purchased. *or* Contact an Authorized Service Center *or* Contact the Vari-Lite Customer Service Department, 9am -6pm CST Monday through Friday, at the following:

phone: 1 877 -VARI-LITE (1-877-827-4548) or +1-214-647-7880

email: [customerservice@genlytecontrols.com](mailto:customerservice@genlytecontrols.com)

### Additional Resources

For additional resources and documentation, please visit our website at [www.vari-lite.com](http://www.vari-lite.com) and follow the Support link



## ***CHAPTER 1.***

### **Description**

This chapter contains descriptions of luminaire features and components, along with a list of accessories that are available.

- **Features**
- **Components**

## Features

---

### Features List

#### VL3500™ Wash & VL3500™ Wash FX Luminaires

- Three-filter CYM color mixing system.
- Variable CTO color correction wheel.
- Full field dimming system.
- Dual blade strobe system.
- Fan cooled.
- UV/IR glass.
- Dual wattage, double-ended lamp capable of operation at 900W (Standby Mode), 1200W or 1500W – mode selectable from fixture or console.
- VARI\*BRITE™ mode - produces a tight, intense column of light.
- Zoomable beam optics mechanism for continuous beam size control with 10° to 50° range - dependent on the lens configuration.
- Dual, five-position (plus open) fixed color wheels.
- Five-position aperture wheel: 52, 40, 35, 30, and 25 mm (VL3500™ Wash only).
- One rotating FX pattern wheel with four rotatable and indexable positions and one open position (VL3500™ Wash FX only).
- Interchangeable front lenses: Fresnel and Plano Convex Stipple (standard on both models).
- Additional Plano Convex Clear front lens (VL3500™ Wash only).
- Additional ULTRA Clear front lens (VL3500™ Wash FX only).
- Repositional pan/tilt system.
- Control by DMX512 protocol.

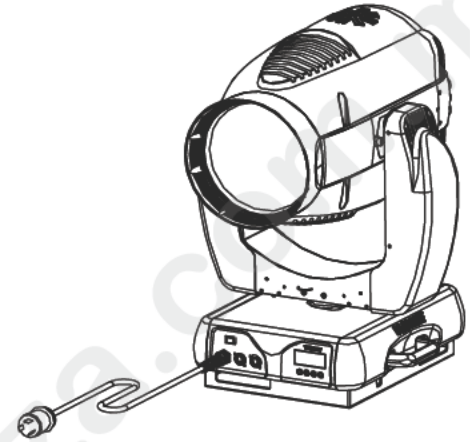

**WARNING:** Some exceptional conditions apply to the safe operation of the VL3500™ Wash Luminaire and the VL3500™ Wash FX Luminaire. See “Warnings and Cautions” on page 13.

---

---

# Components

## Included Items: VL3500 Wash Luminaire

The following illustration shows all the items included with the luminaire.

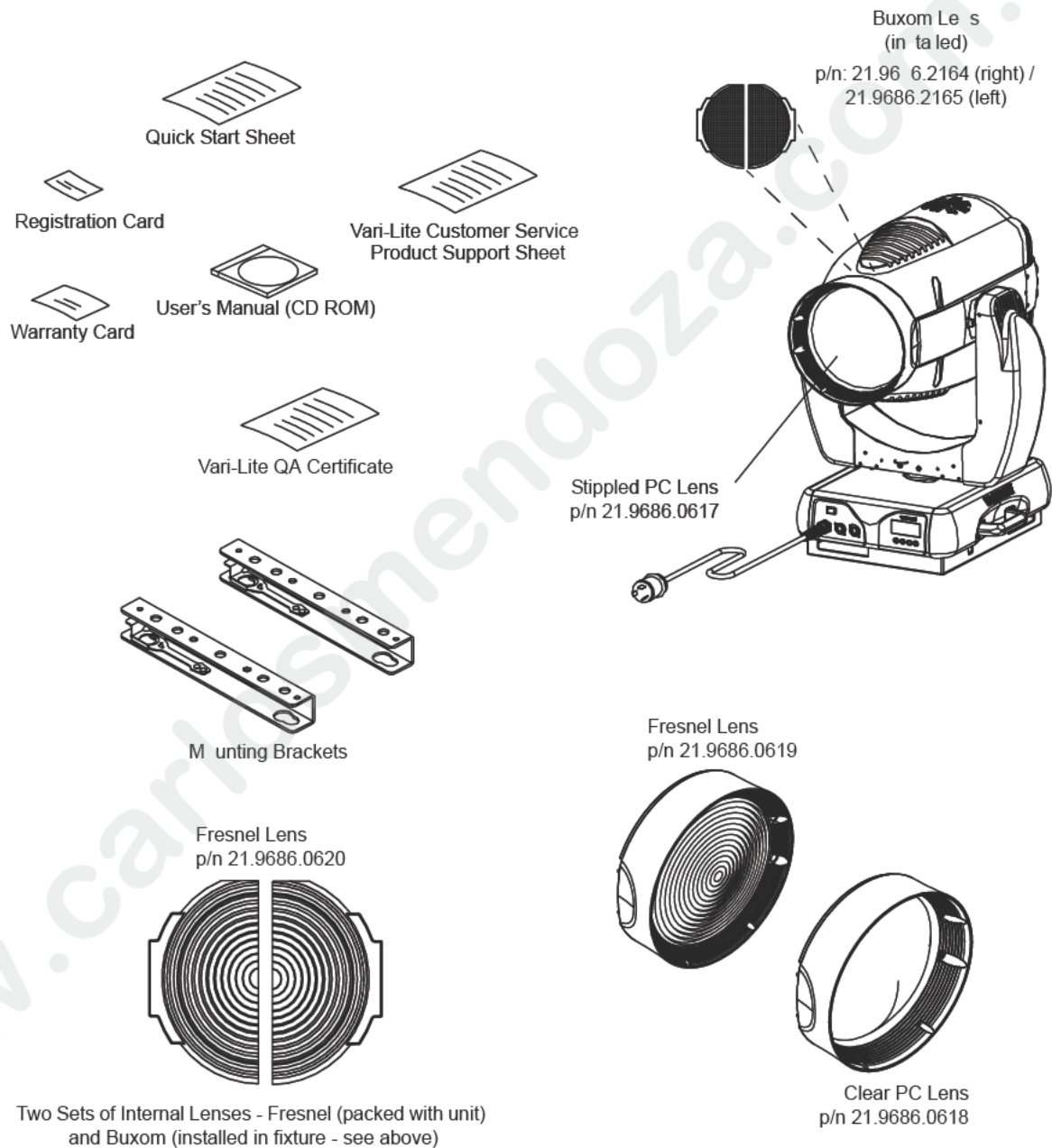

Figure 1-1: VL3500™ Wash Luminaire Packing List

## Included Items: VL3500 Wash FX Luminaire

The following illustration shows all the items included with the luminaire.

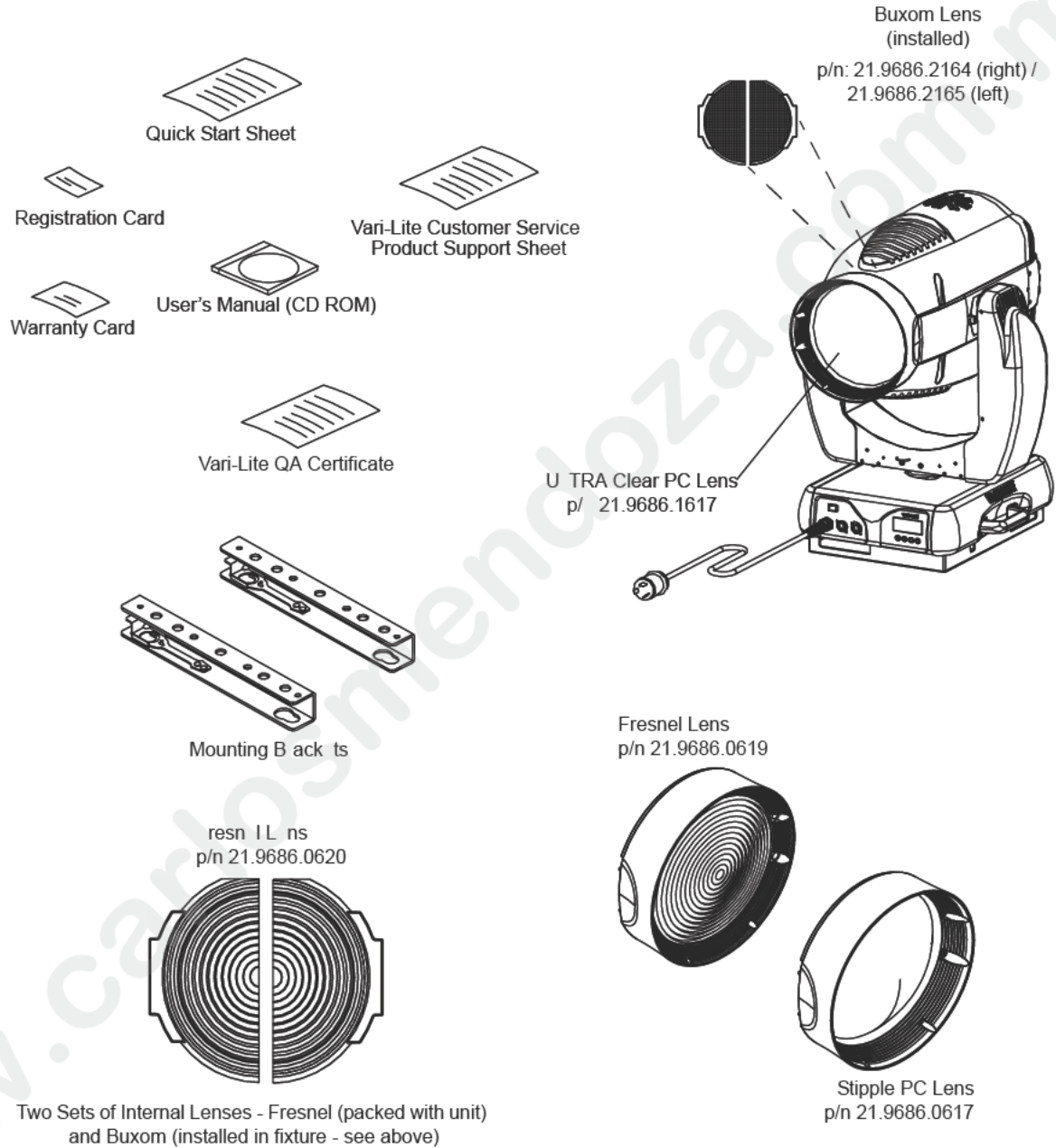

Figure 1-2: VL3500™ Wash FX Luminaire Packing List



---

## Replacement Items/Accessories

The following optional and/or replacement items can be ordered directly from Vari-Lite. (Please order by Vari-Lite part number.)

Vari-Lite P/N	Accessory
21.9686.0617	Front Lens, Stipple
21.9686.0618	Front Lens, Clear PC
21.9686.0619	Front Lens, Fresnel
21.9686.1617	Front Lens, ULTRA Clear PC
21.9686.0620	Internal Lens, Fresnel
21.9686.2164	Internal Lens, Buxom (Right)
21.9686.2165	Internal Lens, Buxom (Left)
22.9620.0194	Safety Cable Assembly
23.9623.0177	DMX Termination Connector Assembly
55.6840.0001	Truss Hook, Mega-Clamp, Round and Square
55.6841.0001	Truss Hook, Mega-Claw for 2" Round Tube
71.9686.1502	Lamp, Osram SharXS® HTI® 500 W/D7/60 Metal Halide

## Luminaire Overview

The following illustration shows the external luminaire components and controls.

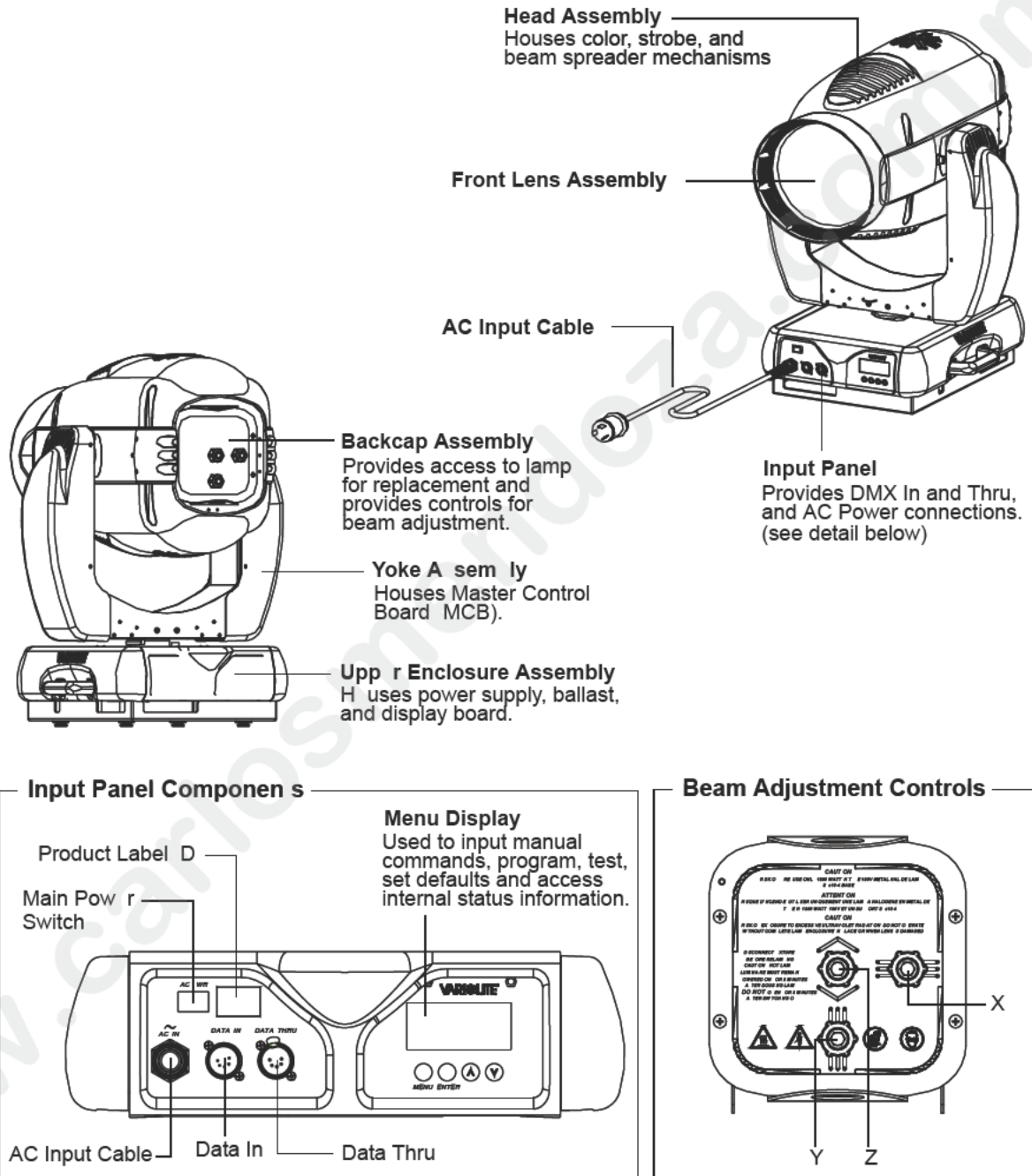

Figure 1-3: VL3500™ Wash & VL3500™ Wash FX Luminaires External Components and Controls



## **CHAPTER 2.**

# **Installation**

This chapter contains instructions for installation of the luminaire. It includes connecting power and data, along with instructions for powering up the luminaire for the first time and addressing it within your system.

- **Power and Data Cabling Requirements**
- **Warnings and Cautions**
- **Installation Procedures**
- **Powering Up**
- **Addressing**
- **Powering Down and Packing Up**

# Power and Data Cabling Requirements

## Power

The luminaire requires standard AC power distribution from 200-240 VAC, 50/60 Hz. 10 amps is required.

Depending on the application, the luminaire's AC input cable may require a different connector. If required, install a new connector meeting your requirements using the following wire color code:

Wire *	Connection
Green/Yellow	AC Ground
Blue	AC Neutral
Brown	AC Line

\* International (Harmonized) Standard



**WARNING:** DO NOT connect to three-phase Delta service in countries with 240 volt power.

**Note:** The lamp will not strike below 180 volts RMS. The following socket configurations are typical; other countries can use different socket configurations.

For single-phase power at 200-240 volts RMS:

Connection	Pin
AC Neutral	X
AC Line	Y
Ground (Earth)	G



For three-phase power at 208 volts RMS:

Connection	Pin
Phase 1	X
Phase 2	Y
Ground (Earth)	G



## Data Cables

The VL3500™ Wash Luminaire are equipped with two, 5-pin XLR connectors for DATA IN and DATA THRU (out) applications. DATA IN requires a 5-pin, female XLR connector and DATA THRU requires a 5-pin, male XLR connector. When purchasing or constructing data cables, it is important that not only the correct cable type be used, but also quality cable to ensure a reliable DMX512 system. Your cabling should meet the following USITT DMX specification requirements:

- Suitable for use with EIA485 (RS485) operation at 250k baud.
- Characteristic impedance 85-150 ohms, nominally 120 ohms.
- Low capacitance.
- Two twisted pairs.
- Foil and braid shielded.
- 24 AWG minimum gauge for runs up to 1000 feet (300m).
- 22 AWG minimum gauge for runs up to 1640 feet (500m).

**Note:** Microphone type cables and other general purpose, two-core audio or signal cables are not suitable for use with DMX512.

The XLR 5-pin connectors should be wired as follows:

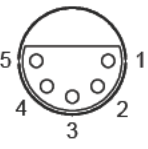
Pin Wire Code to XLR Connectors						
<b>Data Thru Cable Pinout</b>  Male Conn	<b>Pin 1</b> Foil & Braid Shield	<b>Pin 2</b> 1st conductor of 1st twisted pair  Data (-)	<b>Pin 3</b> 2nd conductor of 1st twisted pair  Data (+)	<b>Pin 4</b> 1st conductor of 2nd twisted pair  Data (-)	<b>Pin 5</b> 2nd conductor of 2nd twisted pair  Data (+)	<b>Data In Cable Pinout</b>  Female Conn

**Note:** Refer to the USITT Recommended Practice for DMX512 guide for additional information regarding DMX512 systems. How to obtain a copy is detailed in [“Additional Documentation”](#) on page 1.

## Recommended Cable Types/Manufacturers

These are only a few of the suitable cable types. Any quality EIA485, twisted pair, 120 ohm, shielded cable will also work.

Table 2-1: Recommended Cable Types

Type	Pairs	ZΩ*	Jacket	AWG	Use	Temp (F)
Belden Cables						
1215A	2	150	PVC	26	IBM Type 6 Office cable	75
1269A	2	100	PTFE	22 (Solid)	High Temp, Plenum cabl	200
8102	2	100	PVC	24	UL2919	80
8132	2	120	PVC	28	UL2919	80
8162	2	100	PVC	24	UL2493	60
82729	2	100	PTFE	24	High Tem Plenum cable	200
88102	2	100	PTFE	24	High Temp, Plenum cable	200
89696	2	100	PTFE	22	High Temp, Plenum cable	200
89729	2	100	PTFE	24	High Temp, Plenum cable	200
89855	2	100	PTFE	22	High Temp, Plenum cable	200
9729	2	100	PVC	24	UL2493	60
9804	2	100	PVC	28	UL2960	60
9829	2	100	PVC	24	UL2919	80
9842	2	120	PVC	24	UL2919	80
Proplex Cables						
PC224P	2	110	Polyurethane	22	Heavy Duty and Portable	105
PC224T	2	110	PVC	22	UL2464	105
PC226T	3	110	PVC	22	UL2464	

\* Characteristic Impedance

## Male Termination Connector

A male XLR termination connector is required at the last luminaire (or "far end of the line") to prevent signal reflections. Signal reflections may cancel out the signal at certain line lengths, resulting in errors. The terminator is also necessary for software downloads and running tests on multiple luminaires. To construct your own connector, you will need the following components:

- 5-pin, male XLR connector.
- Two 1/4W 5% 120 ohm resistors.

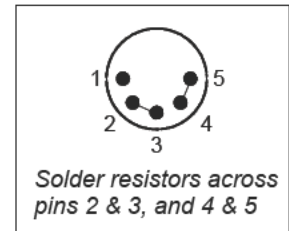

**Note:** A male termination connector is also available as an accessory from Vari-Lite. See "Replacement Items/Accessories" on page 7.

## Warnings and Cautions

---

### Exceptional Safety Information for the VL3500 Wash

---

The light intensity and power density of the VL3500™ Wash Luminaire exceeds that of other fixtures typically used in this application. The warnings and cautions that follow are critically important to the safe operation of the VL3500™ Wash. This product is for commercial use only. If you have any questions about the safe installation and operation of the VL3500™ Wash Luminaire, please contact Vari-Lite customer service at 1-877-VARI-LITE (1-877-827-4548), +1-214-647-7880, or [customerservice@genlytecontrols.com](mailto:customerservice@genlytecontrols.com).

---

---

**WARNING: Light Beam Projects Intense Heat**

Do not illuminate objects within 3.5 m (11.5 feet) of the VL3500™ Wash Luminaire. Objects within this range can scorch, melt, or ignite from the heat projected by the light beam.

---

---

**WARNING: High Intensity Light Output**

Do not look directly into the light beam. Avoid looking at nearby surfaces illuminated by the beam. It is hazardous to operate luminaires without lens or shield. Shields, lenses, or ultraviolet screens must be changed if they have become visibly damaged to such an extent that their effectiveness is impaired. For example, by cracks, deep scratches, or coating breakdown.

---

---

**WARNING: Hot Exterior Surfaces**

The exterior surfaces of the luminaire can get very hot - up to 170°C (338°F). Do not touch any surface of the luminaire while it is operating. Keep all combustible materials a minimum of 200 mm (8 inches) away from the luminaire. To maintain cooling fan operation after the lamp is doused, keep the luminaire powered on for 5 minutes. Wait an additional 5 minutes before touching the luminaire.

---

---

**CAUTION: Operating Environment**

Do not operate the luminaire when the ambient temperature exceeds 40°C (104°F). Do not attempt to bypass the mostatic switches.

---

---

**WARNING: Approved Lamp Type**

Use *only* approved lamp types in VL3500™ Wash Luminaire. The following lamps are approved for use: Osram SharXS® HTI® 1500 W/D7/60 metal halide lamp (shipped with units), Philips / MSR 1510 Gold™ SA/DE Lamp, or GE CSR 1500/S/DE/60 96800 Lamp. Installing any other lamp types can be hazardous. Dispose of used lamps properly. Users can check the latest version of Vari-Lite Technical Notice TN-248, on the Vari-Lite web site, for all approved lamps.

---

---

## Installation Procedures

### Hanging the Luminaire

The VL3500™ Wash Luminaire can be hung horizontally or vertically from any structure designed to work with the type of load created by this moving luminaire. Two mounting bracket assemblies (provided) are used to attach truss hooks or other mounting hardware as required. Many compatible truss hooks are available from different manufacturers for your particular needs.

A minimum of one hook per truss hook bracket is required. If mounting method does not use truss hooks, two attachment points per truss hook bracket are required. When attaching more than one point on a single bracket, the attach points must be spaced as far apart as possible using the supplied mounting holes.

#### Install mounting hardware and brackets:

Step 1. Install truss hooks on two provided truss hook brackets as required.

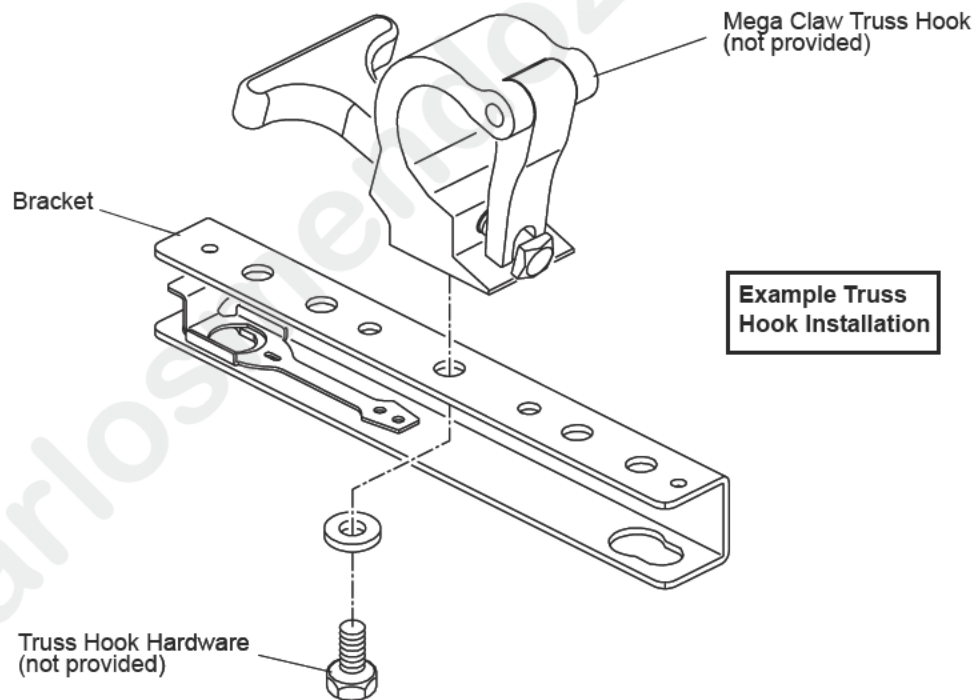

Figure 2-1: Installing Truss Hooks



**Note:** Various types of truss hooks can be used. The Mega Claw truss hook (as shown in the example above) as well as many other standard hooks, can be ordered separately.



- Step 2. Determine required configuration of bracket installation. Brackets may be installed in either orientation as shown.

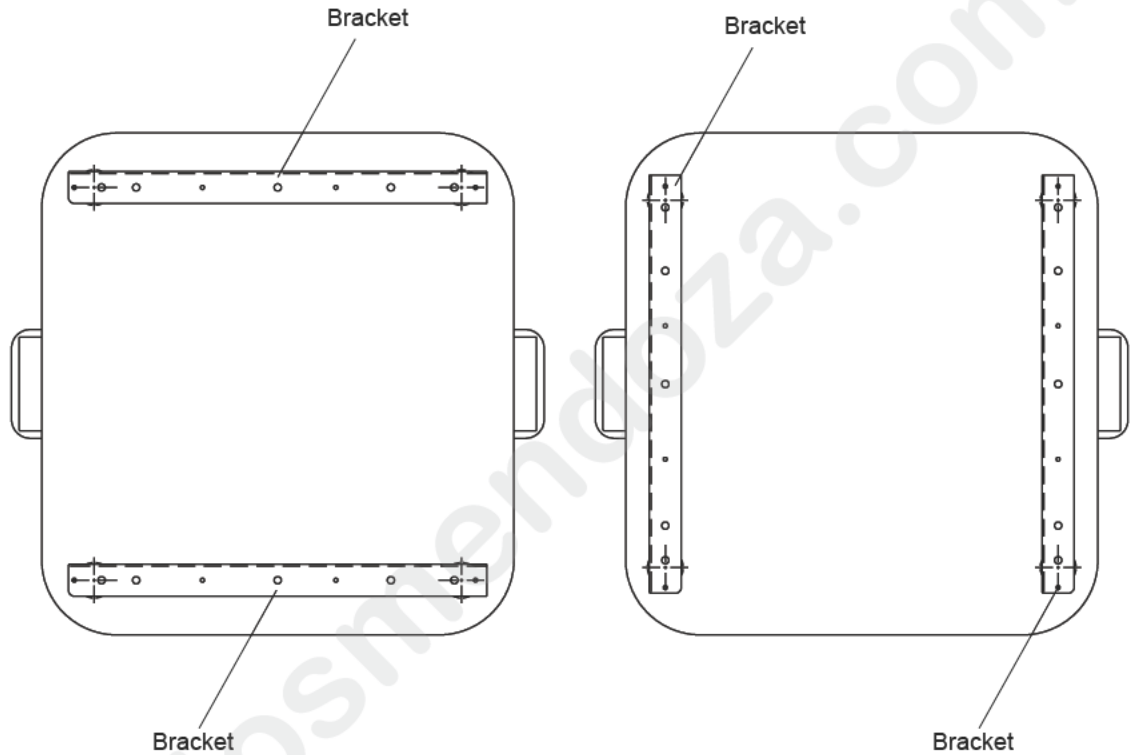

**Figure 2-2: Bracket Orientation Options**

- Step 3. While pulling up on locking mechanism release, fit keyed holes onto raised mounting buttons at bottom of enclosure. Slide forward and release locking mechanism to lock in place. Ensure brackets are locked securely. (Always face brackets in same direction as shown.)



**WARNING:** Ensure that the bracket locking mechanism is fully seated after the bracket is installed on the luminaire.

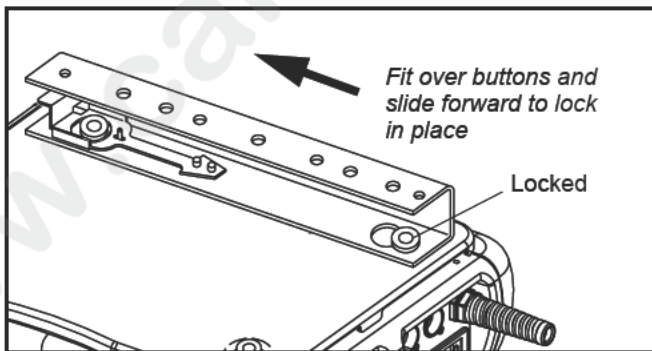
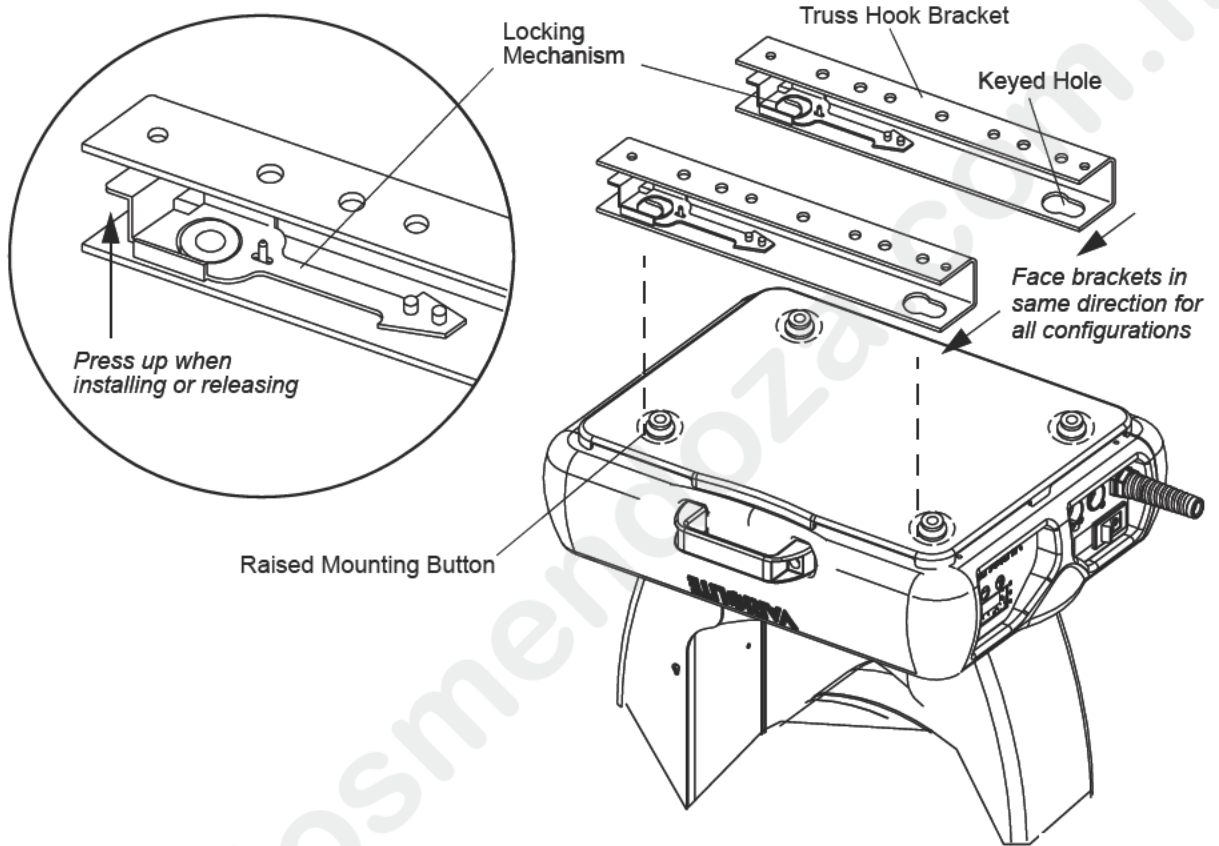

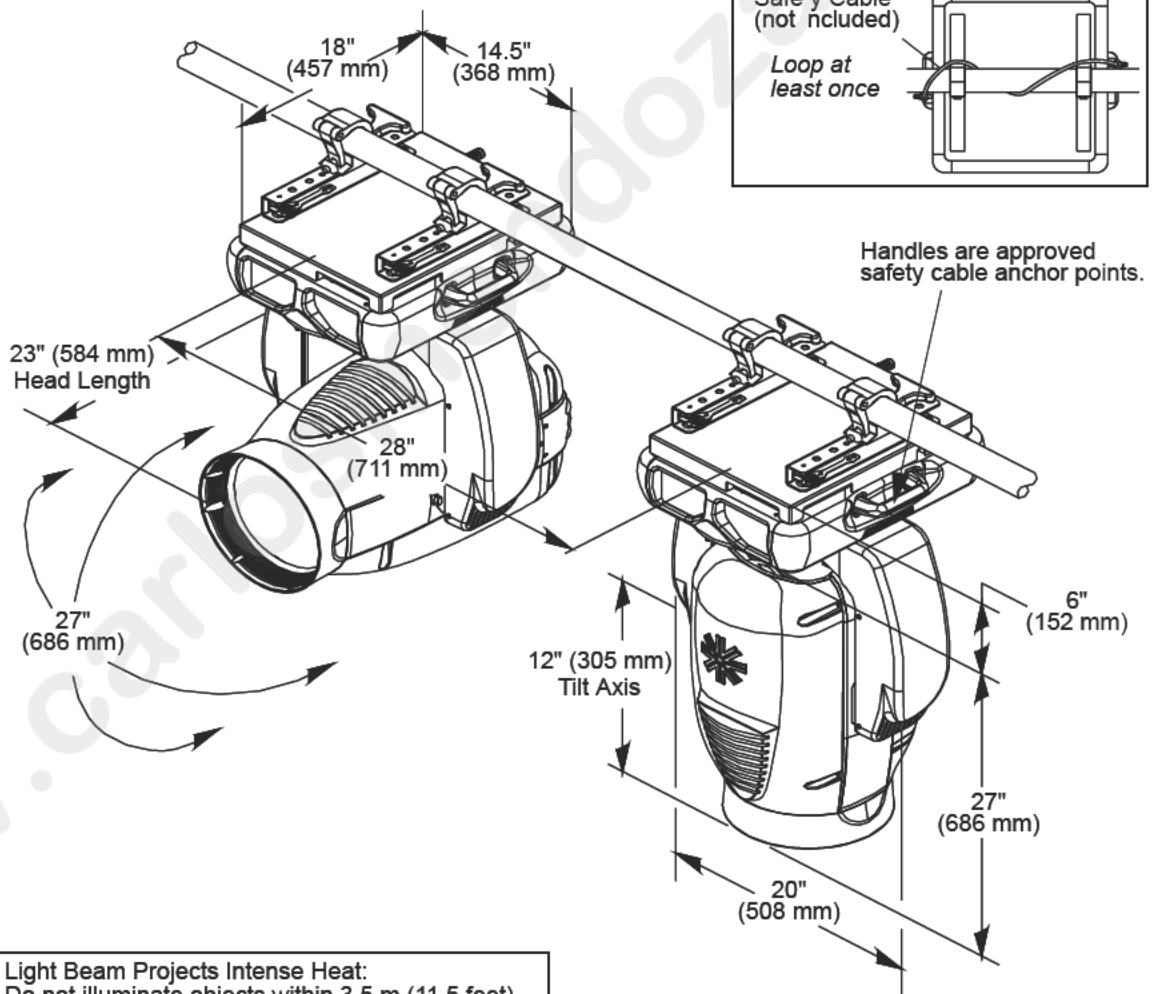
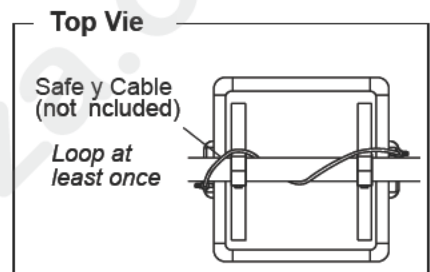



Figure 2-3: Installing Brackets on Luminaire Enclosure

**Installing in Truss:**

- Step 1. Using two people, lift luminaire into mounting position.
- Step 2. Secure in place with truss hook. Ensure truss hook hardware that locks hook in place (e.g. wing bolt) is properly tightened and that luminaire is fully supported.
- Step 3. Attach safety cable (as required) as follows:
  - a. Connect one end of cable to luminaire handle.
  - b. Loop at least once around truss/pipe and attach other end of cable to other handle.
- Step 4. Connect power and data cables according to procedure given in “Connecting Data and Power” on page 18.

 **Safety Cable:**  
Recommended for all hanging installations and may be required by local codes.



 **Light Beam Projects Intense Heat:**  
Do not illuminate objects within 3.5 m (11.5 feet).  
See *Warnings and Cautions* in this chapter.

**Figure 2-4: Hanging Configuration and Dimensions**

## Floor Mounting the Luminaire

The luminaire enclosure is sufficient to stabilize the luminaire in a floor installation, provided that the mounting surface is flat and sturdy.

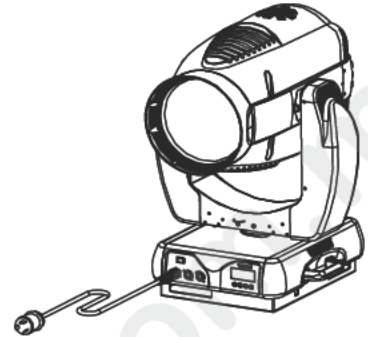
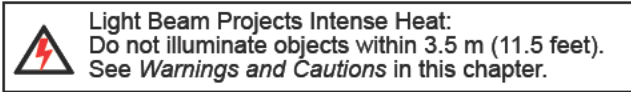

## Connecting Data and Power

A maximum of 32 luminaires may be connected in any one DMX data link.



**Note:** This maximum limit applies to the luminaire "daisy chain" only. Your system or console may require fewer luminaires on a single data link path. Consult your console documentation for more information.

### To connect power and data:

- Step 1. Connect data cable from console to first luminaire in chain at DATA IN connector.
- Step 2. If required, connect additional data cables from DATA THRU connectors to DATA IN connectors of remaining luminaires in link.
- Step 3. At last luminaire in link, install male termination connector at DATA THRU connector. (Luminaires and other devices on the same DMX chain may not function properly without termination.)
- Step 4. Connect AC input cable connector to power input source.
- Step 5. Dress AC input and data cables and secure them so they do not interfere with luminaire head and yoke movement.

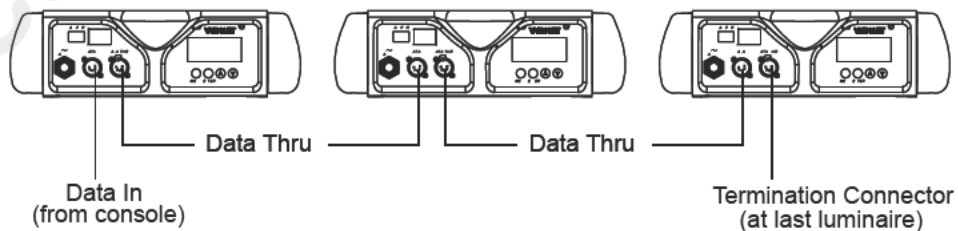

Figure 2-5: Connecting Power and Data

# Powering Up

---

## Power Up and Configuration Procedure

Because Lamp On is the default state, the lamp strikes when the luminaire is powered up for the first time. When AC power is applied, the luminaire immediately begins a calibration sequence that steps it through pan and tilt movements. The internal color and beam mechanisms also move through full range of motion. After calibration, the luminaire head either stops at its "home" position (which positions the pan axis at mid-rotation and the head parallel to the yoke with the lens pointing away from the luminaire upper enclosure) or it moves to its current DMX-defined position when DMX data is present. All internal mechanisms also move to their "home" or DMX-defined positions.

Subsequently, depending on the luminaire's setting for Lamp Power-Up State (refer to "[Menu System Function Chart](#)" on page 53), when power is applied, the arc lamp will either **a)** "strike" or ignite - Lamp On (*default*), **b)** await calibration and then strike - Cal On, or **c)** await manual command to strike - Lamp Off.



**CAUTION:** Before applying power, be sure the luminaire is hung or positioned so that the head and yoke can move freely without restriction.

---



**WARNING:** The light beam projects intense heat. Objects within 3.5 m (11.5 feet) can be damaged by the beam. Observe the power-up sequence to ensure that the beam does not illuminate objects within this range. See "[Warnings and Cautions](#)" on page 13.

---

---

### To power up:

- At each luminaire, apply power by switching power switch to "I" (ON) position. Luminaire will automatically step through following procedure:
  - a. If Lamp Power-Up State is set to Lamp On, lamp will strike (ignite).
  - b. Luminaire will cycle through calibration and stop at "home" position.
  - c. If Lamp Power-Up State is set to Cal On, lamp will strike (ignite) at end of calibration sequence.

## Addressing

---

### Program Starting Address

The address setting for DMX console controlled systems is entered using the Menu Display (refer to "Menu Operation" on page 50). The luminaire retains the DMX address even when power is removed.



**Note:** Refer to your console operating instructions for specific information regarding DMX addressing requirements.

---

#### Program a DMX starting address:

- Step 1. Press [Menu].
- Step 2. Press [Up] / [Down] arrows until **Address** appears. Press [Enter].
- Step 3. Press [Up] / [Down] arrows to enter starting address.
- Step 4. Press [Enter] to set.

---

### Program Starting Address Without Calibrating Luminaire

It is possible to bypass the calibration sequence and go directly to the Menu Display programming in order to pre-program an address setting.

#### Program starting address without calibrating luminaire or striking the lamp:

- While powering up luminaire, press and hold [Menu] until "Starting" is replaced by the current DMX address in the menu display. Program address as in [Program Starting Address](#) above.



**Note:** The luminaire will require a reset to restore control.

---

# Powering Down and Packing Up

## Pack-Up Cues for Shipping: VL3500™ Wash Luminaire

To prepare the VL3500™ Wash Luminaire for shipment, Vari-Lite recommends specific pack-up cues and console default values. In particular, to minimize the possibility of damage during transport, set the DMX values for the VARI\*BRITE® mode and Zoom to 0 (zero) prior to shipment. For the complete list of all recommended DMX shipping default values, see [Table 2-2](#) below.

The DMX values in [Table 2-2](#) should be included as the default settings for console profiles. If these values are set as the console default states, a simple release of the fixture initiates the pack-up cue.

If a particular console does not set the VL3500™ Wash Luminaire to these default values, Vari-Lite strongly recommends the creation of a "pack-up" cue that, at the least, sets VARI\*BRITE™ and Zoom values to 0, and preferably sets all of the default values recommended in [Table 2-2](#).

**Table 2-2: Pack-up Cues and Console Default States for VL3500™ Wash Luminaires**

DMX Channel	Parameter	Recommended Default Value
1	Intensity	0
2	Hi Byte Pan	32768 (mid position)
3	Lo Byte Pan	
4	Hi Byte Tilt	32768 (mid position)
5	Lo Byte Tilt	
6	VARI*BRITE® Mode	0 (closed)
7	Zoom	0 (narrow)
8	CTO Mixer	0 (open)
9	Cyan (Blue) Mixer	0 (open)
10	Yellow (Amber) Mixer	0 (open)
11	Magenta Mixer	0 (open)
12	Color Wheel 1	0
13	Color Wheel 2	0
4	Strobe	0 (open)
15	Aperture Wheel	0
16	Focus Time	255
17	Color Time	255
18	Beam Time	255
19	Control Channel	0

If no console is present, then a completed calibration routine will ensure that these defaults are met.

## Pack-Up Cues for Shipping: VL3500™ Wash FX Luminaire

To prepare the VL3500™ Wash FX Luminaire for shipment, Vari-Lite recommends specific pack-up cues and console default values. In particular, to minimize the possibility of damage during transport, set the DMX values for the VARI\*BRITE™ mode and Zoom to 0 (zero) prior to shipment. For the complete list of all recommended DMX shipping default values, see Table 2-3 below.

The DMX values in Table 2-3 should be included as the default settings for console profiles. If these values are set as the console default states, a simple release of the fixture initiates the pack-up cue.

If a particular console does not set the VL3500™ Wash FX Luminaire to these default values, Vari-Lite strongly recommends the creation of a "pack-up" cue that, at the least, sets VARI\*BRITE™ and Zoom values to 0, and preferably sets all of the default values recommended in Table 2-3.

Table 2-3: Pack-up Cues and Console Default States for VL3500™ Wash FX Luminaire

DMX Channel	Parameter	Recommended Default Value
1	Intensity	0
2	Hi Byte Pan	32768 (mid position)
3	Lo Byte Pan	
4	Hi Byte Til	32768 (mid position)
5	Lo Byte It	
6	VARI*BRITE® Mode	0 (closed)
7	Zoom	0 (narrow)
8	Color Mixer	0 (open)
9	Cyan (Blue) Mixer	0 (open)
10	Yellow (Amber) Mixer	0 (open)
11	Magenta Mixer	0 (open)
12	Color Wheel 1	0
13	Color Wheel 2	0
14	Strobe	0 (open)
15	FX Wheel	0-255
16	FX Index Hi Byte	32768 (mid position)
17	FX Index Lo Byte	
18	Focus Time	255
19	Color Time	255
20	Beam Time	255
21	FX Time	255
22	Control	0



**Note:** When no console (DMX) is attached, a simple reset of the fixture will default all values to the required "pack-up" settings.



---

## Packing for Transportation and Shipment

For transportation and shipping case requirements, see Technical Notice TN-235, "Transportation and Shipping Case Requirements" in the "Support" area of the Vari-Lite website at [www.vari-lite.com](http://www.vari-lite.com)

www.carlosmendoza.com.mx

---

Notes

[www.carlosmendoza.com.mx](http://www.carlosmendoza.com.mx)



## ***CHAPTER 3.***

# **Operation**

This chapter contains instructions for operating the luminaire using DMX control and for updating the internal software.

- **DMX Operation**
- **DMX Mapping**
- **Luminaire Timing**
- **Updating Software**

# DMX Operation

## Channel Mapping: VL3500™ Wash Luminaire

These tables assume a DMX start address of 1. When a different starting address is used, this address becomes channel 1 function and other functions follow in sequence. (There is only one DMX mode for this luminaire, which is Enhanced 16-bit Mode.)

**Table 3-1: VL3500™ Wash Luminaire Enhanced 16-Bit Mode**

DMX Channel	Parameter	Range DMX	Range %	Description
1	Intensity	0 - 255	0 - 100%	Linear Intensity control from 0 (closed) to 255 (open)
2	Pan - High Byte	0 - 65535	0 - 100%	16 bit control of Pan - 530° of movement.
3	Pan - Low Byte			
4	Tilt - High Byte	0 - 65535	0 - 100%	6 bit control of Tilt - 260° of movement.
5	Tilt - Low Byte			
6	VARI* <i>BRITE</i>	0 - 255	0 - 100%	Controls split lens assy. 0 (closed) to 255 (open).
7	Zoom	0 - 255	0 - 100%	Controls zoom assy. 0 (narrow) to 255 (wide).
8	CTO	0 - 255	0 - 100%	Controls CTO color wheel. 0 (open) to 255 (full saturation).
9	Cyan	0 - 255	0 - 100%	Controls Cyan color wheel. 0 (open) to 255 (full saturation).
10	Yellow	0 - 255	0 - 100%	Controls Yellow color wheel. 0 (open) to 255 (full saturation).
11	Magenta	0 - 255	0 - 100%	Controls Magenta color wheel. 0 (open) to 255 (full saturation).
12	Fixed Color 1	0 - 255	0 - 100%	Controls Fixed color wheel 1. Linear control from 0 to 216. From 217 to 255 will give different speeds of wheel spin. Center DMX values... Position 1 = Open - DMX 0 Position 2 = Red - DMX 37 Position 3 = Yellow - DMX 72 Position 4 = Magenta - DMX 107 Position 5 = Kelly Green - DMX 143 Position 6 = Congo Blue - DMX 179
13	Fixed Color 2	0 - 255	0 - 100%	Controls Fixed color wheel 2. Linear control from 0 to 216. From 217 to 255 will give different speeds of wheel spin. Center DMX values... Position 1 = Open - DMX 0 Position 2 = Blue - DMX 37 Position 3 = Amber - DMX 72 Position 4 = Dark Fuchsia - DMX 107 Position 5 = Orange - DMX 143 Position 6 = Green - DMX 179

Table 3-1: VL3500™ Wash Luminaire Enhanced 16-Bit Mode

14	Strobe	0 - 255	0 - 100%	Controls Strobe mechanism. 0 to 2 = Open 3 to 5 = Closed 6 to 7 = Slow Random 8 to 10 = Medium Random 11 to 12 = Fast Random 13 to 255 = Strobe Speed Range (255 - fast)
15	Aperture Wheel	0 - 255	0 - 100%	Controls aperture wheel using the following levels from 0 to 216. From 217 to 255 will give different speeds of wheel spin DMX values... Position 1 - 52mm = DMX 0 - 4 Position 2 - 40mm = DMX 4 - 86 Position 3 - 35mm = DMX 87 - 129 Position 4 - 30mm = DMX 130 - 172 Position 5 - 25mm = DMX 173 - 216
16	Focus Time	0 - 255	0 - 100%	Allows for luminaire timing of pan and tilt. Profile should default to DMX 255 for smoothest console fade times.
17	Color Time	0 - 255	0 - 100%	Allows for luminaire timing of color wheels. Profile should default to DMX 255 for smoothest console fade times.
18	Beam Time	0 - 255	0 - 100	Allows for luminaire timing of zoom and VARI* BRITE. Profile should default to DMX 255 for smoothest console fade times.
19	Control	0 - 255	0 - 100%	Used to strike/douse lamp, set lamp levels, and other various functions, as well as resetting the luminaire via the console. DMX values are... *Color Snap ON = DMX 20 - 25 *Color Snap OFF (Norm) = DMX 30 - 35 *Dimmer Snap ON = DMX 40 - 45 *Dimmer Snap OFF (Norm) = DMX 50 - 55 *Zoom Norm = DMX 60 - 65 *Zoom Studio = DMX 70 - 75 Full Luminaire Reset = DMX 81 - 87 ReCal Color = DMX 100 - 104 ReCal Beam = DMX 126 - 130 ReCal Dim/Strobe = DMX 138 - 142 Lamp OFF = DMX 165 - 171 Lamp @ 900W = DMX 176 - 184 Lamp @ 1200W = DMX 189 - 194 Lamp @ 1500W = DMX 199 - 204 Lamp ON = DMX 249 - 255
Note that these functions do not require the 3 sec rule to execute. All other values do require 3 sec rule.				

## Channel Mapping: VL3500™ Wash FX Luminaire

These tables assume a DMX start address of 1. When a different starting address is used, this address becomes channel 1 function and other functions follow in sequence. (There is only one DMX mode for this luminaire, which is Enhanced 16-bit Mode.)

**Table 3-2: VL3500™ Wash FX Luminaire Enhanced 16-Bit Mode**

DMX Channel	Parameter	Range DMX	Range %	Description
1	Intensity	0 - 255	0 - 100%	Linear Intensity contro from 0 (closed) to 255 (open)
2	Pan - High Byte	0 - 65535	0 - 100%	16 bit control of Pan - 530° of movement.
3	Pan - Low Byte			
4	Tilt - High Byte	0 - 65535	0 - 100%	16 bit control of Tilt - 260° of movement.
5	Tilt - Low Byte			
6	VARI* <i>BRITE</i>	0 - 255	0 - 100%	Controls split lens assy. 0 (closed) to 255 (open).
7	Zoom	0 - 255	0 - 100%	Controls zoom assy. 0 (narrow) to 255 (wide).
8	CTO	0 - 255	0 - 100%	Controls CTO color wheel. 0 (open) to 255 (full saturation).
9	Cyan	0 - 255	0 - 100%	Controls Cyan color wheel. 0 (open) to 255 (full saturation).
10	Yellow	0 - 255	0 - 100%	Controls Yellow color wheel. 0 (open) to 255 (full saturation).
11	Magenta	0 - 255	0 - 100%	Controls Magenta color wheel. 0 (open) to 255 (full saturation).
12	Fixed Color 1	0 - 255	0 - 100%	Controls Fixed color wheel 1. Linear control from 0 to 216. From 217 to 255 will give different speeds of wheel spin. Center DMX values... Position 1 = Open - DMX 0 Position 2 = Red - DMX 37 Position 3 = Yellow - DMX 72 Position 4 = Magenta - DMX 107 Position 5 = Kelly Green - DMX 143 Position 6 = Congo Blue - DMX 179
13	Fixed Color 2	0 - 255	0 - 100%	Controls Fixed color wheel 2. Linear control from 0 to 216. From 217 to 255 will give different speeds of wheel spin. Center DMX values... Position 1 = Open - DMX 0 Position 2 = Blue - DMX 37 Position 3 = Straw - DMX 72 Position 4 = Dark Fuchsia - DMX 107 Position 5 = Orange - DMX 143 Position 6 = Green - DMX 179

Table 3-2: VL3500™ Wash FX Luminaire Enhanced 16-Bit Mode

14	Strobe	0 - 255	0 - 100%	Controls Strobe mechanism. 0 to 2 = Open 3 to 5 = Closed 6 to 7 = Slow Random 8 to 10 = Medium Random 11 to 12 = Fast Random 13 to 255 = Strobe Speed Range (255 = fast)
15	FX Wheel <sup>(1)</sup>	0 - 255	0 - 100%	Controls FX Wheel using the following levels from 0 to 216. From 217 to 255 will give different speeds of wheel spin. DMX values: Position 1 = Open (Indx) - DMX 0 - 10 Position 2 = Spokes (Indx) - DMX 11 - 32 Position 3 = Night Sky (Indx) - DMX 33 - 54 Position 4 = 4 Hole Ray (Indx) - DMX 55 - 75 Position 5 = Triangle (Indx) - DMX 76 - 97 Position 1 = Open (Rtate) - DMX 98 - 119 Position 2 = Spokes (Rtate) - DMX 120 - 141 Position 3 = Night Sky (Rtate) - DMX 142 - 163 Position 4 = 4 Hole Ray (Rtate) - DMX 164 - 184 Position 5 = Triangle (Rtate) - DMX 185 - 206 Position 1 = Open - DMX 207 - 216
16 17	FX Index	0-65535	0 - 100%	16-bit control of FX Wheel index in either direction.
18	Focus Time	0 - 255	0 - 100%	Allows for luminaire timing of pan and tilt. Profile should default to DMX 255 for smoothest console fade times.
19	Color Time	0 - 255	0 - 100%	Allows for luminaire timing of color wheels. Profile should default to DMX 255 for smoothest console fade times.
20	Beam Time	0 - 55	0 - 100%	Allows for luminaire timing of zoom and VARI* BRITE. Profile should default to DMX 255 for smoothest console fade times.
21	FX Time	0 - 255	0 - 100%	Allows for luminaire timing of FX wheel. Profile should default to DMX 255 for smoothest console fade times.

<sup>(1)</sup> = All effects patterns listed in this section are standard factory load. Additional VL3500 Wash FX custom patterns are available for purchase.

Table 3-2: VL3500™ Wash FX Luminaire Enhanced 16-Bit Mode

22	Control	0 - 255	0 - 100%	<p>Used to strike/douse lamp, set lamp levels, and other various functions, as well as resetting the luminaire via the console. DMX values are...</p> <ul style="list-style-type: none"> <li>*Color Snap ON = DMX 20 - 25</li> <li>*Color Snap OFF (Norm)= DMX 30 - 35</li> <li>*Dimmer Snap ON= DMX 40 - 45</li> <li>*Dimmer Snap OFF (Norm)= DMX 50 - 55</li> <li>*Zoom Norm = DMX 60 - 65</li> <li>*Zoom Studio = DMX 70 - 75</li> <li>Full Luminaire Reset = DMX 81 - 8</li> <li>ReCal Color= DMX 100 - 1 4</li> <li>ReCal Beam= DMX 126 - 130</li> <li>ReCal Dim/Strobe= DMX 138 - 142</li> <li>Lamp OFF= DMX 165 - 171</li> <li>Lamp @ 900W = DMX 176 - 184</li> <li>Lamp @ 1200W DMX 189 - 194</li> <li>Lamp @ 1500W= DMX 199 - 204</li> <li>Lamp ON DMX 249 - 255</li> </ul>
<p>* Note that these functions do not require the 3 sec rule to execute. All other values do require 3 sec rule.</p>				



## Control Channel Functions

Control channel functions allow special actions such as reset, lamp on/off and partial recalibration. These must be executed with zero time transition or with timing disabled. Discrete values must be used; not manual controls such as faders or encoders (see chart below for values).



### WARNING: Light Beam Projects Intense Heat

Do not illuminate objects within 3.5 m (11.5 feet) of the VL3500™ Wash Luminaire. Objects within this range can scorch, melt, or ignite from the heat projected by the light beam.

**Reset** - resets all luminaire mechanisms.

**Lamp On or Lamp Off** - switches lamp on or off.

**Partial Recalibration** - resets only the target mechanism (color, zoom, etc.) without affecting others.

**Table 3-3: Control Channel Functions for the VL3500 Wash and the VL3500 Wash FX**

Control Channel Function	Control Channel % Value	Control Channel DMX Value	
		For 3 Secs or Greater	After 3 Secs
Color Snap ON *	8-10	20-25	*
Color Snap OFF (Norm) *	12-14	30-35	*
Dimmer Snap ON *	16-18	40-45	*
Dimmer Snap OFF (Norm) *	20-22	50-55	*
Zoom Normal *	24 - 25	60 - 65	*
Zoom Studio *	27 - 29	70 - 75	*
Luminaire Reset	32 - 33	81 - 87	0
Lamp Off	65 - 67	165 - 171	0
Lamp On	98 - 100	249 - 255	0
Color Recalibration	39-40	100 - 104	0
Zoom / VARI*BRITE Recalibration	49-51	126 - 130	0
Dimmer Strobe Recalibration	54-56	138 - 142	0
500W lamp runs at 900W	69-72	176 - 184	0
1500W lamp runs at 1200W	74-76	189 - 194	0
1500W lamp runs at 1500W	78-80	199 - 204	0

\* These functions do not require the 3 second rule to execute. Simply set to the desired function value.

**To use control channel functions:**

- Step 1. Select an action to be sent.
- Step 2. Set control channel value for desired action (for example, 84 for reset). Hold value for at least 3 seconds (when applicable).
- Step 3. Set control channel value to zero. (This must occur without any scaling values. Action will be voided if other values are detected between action value and zero.) Some functions do not require this method. Simply set to value and desired effect will occur.



**Note:** A numerical keypad is required for sending values. An encoder or fader does not allow for a quick value change, which is required to effect the control functions. However, the encoders on some consoles include discreet value capability.

---

# DMX Mapping

## Color Control

The luminaire's color system is composed of a color mixing mechanism and two fixed color wheels. The following sections describe these components.

## Color Mixing

The color mixing mechanism is made up of four graduated color disks: cyan, yellow, magenta and CTO (color temperature orange). These disks provide full-spectrum color codes from pastel to saturated color.

Table 3-4: DMX Map for Cyan, Yellow, Magenta and CTO Colors

% Value	DMX Value	Action
0	0	Open
100	255	Full Saturation

## Fixed Color Wheel 1

The fixed color wheels offer timed changes, half and full frame positions, and various spin rates in either direction. The wheel contains six positions, one of which is open. The following illustration shows the standard positions and color configuration:

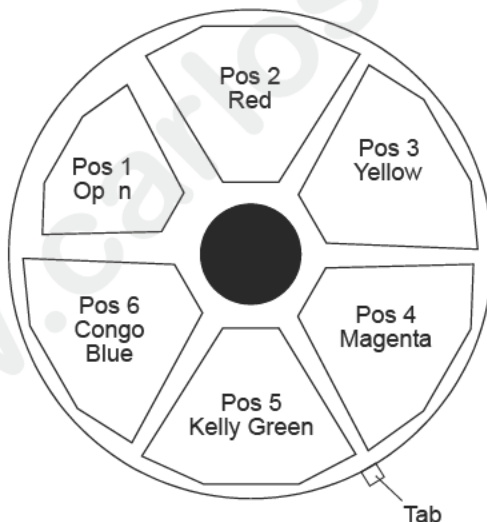

Position	Color Filter	Part Number
1	Open	n/a
2	Red	41.9686.0490
3	Yellow	41.9686.0491
4	Magenta	41.9686.0492
5	Kelly Green	41.9686.0493
6	Congo Blue	41.9686.0494

Figure 3-1: Fixed Color Wheel 1 Positions

## Fixed Color Wheel 2

The wheel contains six positions, one of which is open. The following illustration shows the standard positions and color configuration:

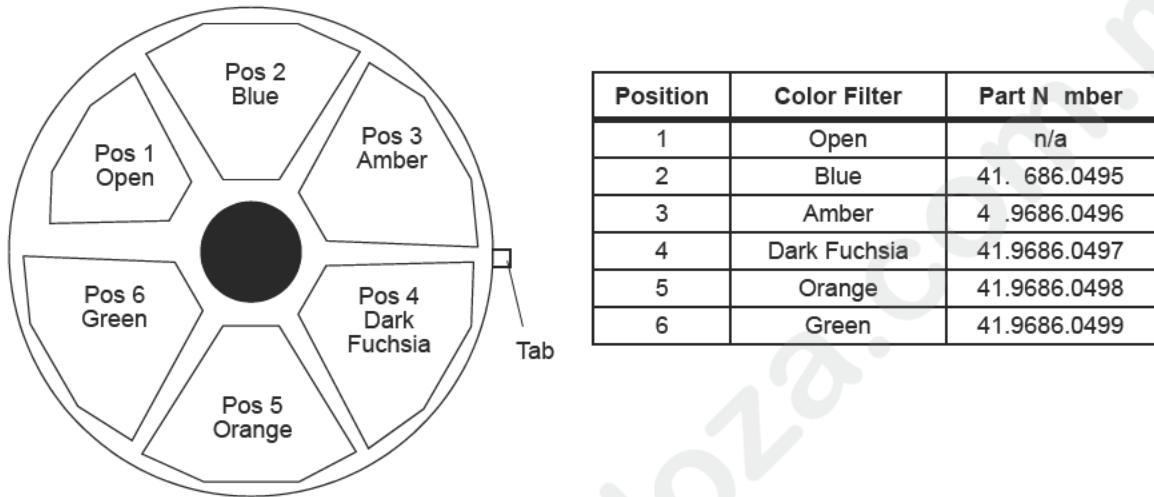

Figure 3-2: Fixed Color Wheel 2 Positions

Table 3-5: DMX Map for Fixed Color Wheels 1 and 2

Posit on	DMX Value	Action
1	0	Open
1.5	19	Half
2	37	Center
2.5	56	Half
3	72	Center
3.5	91	Half
4	107	Center
4.5	126	Half
5	143	Center
5.5	162	Half
6	179	Center
6.5	198	Half



**Note:** All Half Values in Table 3-5 are approximate.

---

## Beam Control

### Strobe

**Table 3-6: DMX Map for Strobe**

% Value	DMX Value	Action
0	0-2	Open
1	3-5	Closed
2	6-7	Slow Random
3	8-10	Med Random
4	11-12	Fast Random
5-100	13-255	Speed Range

### Aperture

**Table 3-7: DMX Map for Aperture (VL3500 Wash Only)**

Description	DMX Value	Action
52 mm	0 - 43	Open
40 mm	44 - 86	Open
35 mm	87 - 129	Open
30 mm	130 - 172	Open
25 mm	173 - 216	Open
	217-255	Spins

## FX Pattern Wheel (VL3500 Wash FX Only)

This wheel has five positions, one being open. The following illustration shows the standard effects pattern configurations:

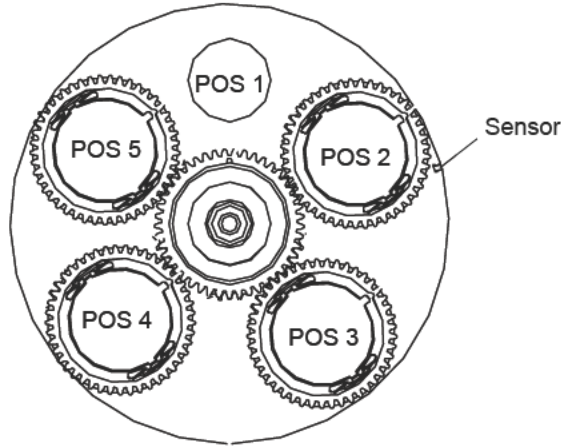

Position	Pattern Style	Part Number
1	Open	n/a
2	Spokes	41.6040.4326
3	Night Sky	41.6040.5011
4	Hole Ray	41.6040.4002
5	Triangle	41.6040.4009

Figure 3-3: FX Pattern Wheel Positions (VL3500 Wash FX Only)



**Note:** All effects patterns listed in this section are standard factory load. Additional VL3500 Wash FX custom patterns are available for purchase.

## Index/Rotation

The FX Pattern wheel operates in two modes: INDEX Mode and ROTATE Mode. The corresponding values are given in the DMX Map Tables below. Patterns will also behave as follows:

- FX Pattern wheel will only stop at whole images.
- It is not necessary for the wheel to complete a full revolution to change an FX Pattern from Index mode to Rotate mode.
- To move between FX Patterns using a fade time, the FX Timing channel (21) must be used.
- Control the FX Pattern wheel using DMX levels from 0 to 216.
- Wheel spins are variable. For CCW, fast to slow, use DMX 217-236. For CW slow to fast, use DMX 237-255.

**Table 3-8: DMX Map for FX Pattern Wheel (VL3500 Wash FX Only)**

Position	Indexing	Rotating	Function
1	0-10	n/a	Open
2	11-32	120-41	Pattern 1
3	33-54	142-163	Pattern 2
4	55-75	16-184	Pattern 3
5	76-97	185-206	Pattern 4
6	98-119	207-216	Pattern 5

The FX Pattern Index function utilizes 16-bit control which offers enhanced resolution whether in INDEX or ROTATE mode.

**Table 3-9: Index/Rotation Range for for FX Pattern Wheel (VL3500 Wash FX Only)**

Function	Range
Index	0-65535
Rotate	0 (CW Max) - 32599 (CW Min) 32600 - 33047 (Stop) 33048 (CCW Min) - 65535 (CCW Max)

# Luminaire Timing

---

## Timing Channel Information

Timing channel control improves the timed moves of certain groups of parameters. We provide up to four timing channels, one for focus (Pan and Tilt), one for color parameters, one for beam parameters, and one for FX Pattern wheel position (VL3500 Wash FX only).

Types of timing control:

- **Timing Control Channel:** the luminaire uses its timing channel value to calculate smooth continuous movement for a given time and transition.
- **Console Timing:** the console calculates the time duration between the DMX increments to be sent for a given time and transition.

Guidelines:

- Timing channels support time values of up to six minutes.
- To use a timing channel instead of console timing it is necessary to set the timing channel to the desired value and set cue and/or parameter time to zero. A combination of time controls can produce unexpected results.
- The default value setting in the profile should be 255 (proportional control) to allow smooth movement when using console timing.
- The timing channel data should change as a snap. A zero value will give the fastest move, however, without any smoothing this can appear "steppy" in console timed moves.

Example:

- Fixed color changes are considerably faster with color time set at zero.



**Note:** Some parameters have been excluded from the timing channels. Wheel spin rate changes are not affected by timing channels.

---



**Table 3-10: VL3500™ Wash and VL3500 Wash FX  
Channel Function / Timing Channel Relationship**

Channel Function	Timing Channel			
	Focus Time	Color Time	Beam Time	FX Pattern Time (FX Only)
Pan (Hi Byte/Lo Byte)	◆			
Tilt (Hi Byte/Lo Byte)	◆			
Blue		◆		
Amber		◆		
Magenta		◆		
CTO		◆		
Color Wheels		◆		
VARI*BRITE / Zoom			◆	
FX Wheel (FX Only)				◆
FX Index (FX Only)				◆

A timing value of zero is full speed. A time value of 100% (or 255 in DMX) enables the associated parameter(s) to follow cue fade time (console time) rather than the timing channel.



**Note:** The particular storing syntax for your console, as well as instructions on how to write part cues, can be found in the operation manual supplied with your console (or consult console manufacturer).

#### To use these channels, you must

- Step 1. Create the cue, including color, gobo, edge and diffusion as required.
- Step 2. Decide which fixtures and which parameter groups will use timing channels.
- Step 3. Assign a value to the particular timing channel(s) you wish to use (for timing information, see chart on next page).
- Step 4. Set console timing (or cue fade time) for parameters and timing channels to zero seconds.
- Step 5. Store cue.



**Note:** Avoid changing timing channel values in a fading cue. This can cause unexpected behavior in the luminaire as the timing channel value is updated over time. Timing channel values and the final destination of the parameters affected by the timing channel should always be sent in a zero count.

Timing channels can be set in either % or 0-255 (DMX) modes, with the following values assigned:

**Table 3-11: Timing Channels Map**

<b>% Value</b>	<b>DMX</b>	<b>= Seconds</b>
	0	Full Speed
	1	0.2
	2	0.4
1	3	0.6
	4	0.8
2	5	1
	6	1.2
	7	1.4
3	8	1.6
	9	1.8
4	10	2
	11	2.2
	12	2.4
5	13	2.6
	14	2.8
6	15	3
	16	3.2
	17	3.4
7	18	3.6
	19	3.8
8	20	4
	21	4.2
	22	4.4
9	23	4.6
	24	4.8
10	25	5
	26	5.2
	27	5.4
11	28	5.6
	29	5.8
	30	6
12	31	6.2
	32	6.4
13	33	6.6
	34	6.8
	35	7.0
14	36	7.2
	37	7.4
15	38	7.6
	39	7.8
	40	8
16	41	8.2

Table 3-11: Timing Channels Map (Continued)

% Value	DMX	= Seconds
	42	8.4
17	43	8.6
	44	8.8
	45	9
18	46	9.2
	47	9.4
19	48	9.6
	49	9.8
	50	10
20	51	10.2
	52	10.4
	53	10.6
21	54	11
	55	1
22	56	1
	57	12
	58	13
23	59	13
	60	14
24	6	14
	62	14
	6	15
25	64	15
	65	16
26	66	16
	67	16
	68	17
27	69	17
	70	18
28	71	18
	72	18
	73	19
29	74	19
	75	20
30	76	20
	77	20
	78	21
31	79	21
	80	21
	81	22
32	82	22
	83	23
33	84	23
	85	23
	86	24

Table 3-11: Timing Channels Map (Continued)

% Value	DMX	= Seconds
34	87	24
	88	25
35	89	25
	90	25
	91	26
36	92	26
	93	27
37	94	27
	95	27
	96	28
38	97	28
	98	29
39	99	29
	100	2
	101	3
40	102	30
	103	30
	104	31
41	105	31
	10	32
42	07	32
	108	32
	109	33
43	110	33
	111	34
4	112	34
	113	34
	114	35
45	115	35
	116	36
46	117	36
	118	36
	119	37
47	120	37
	121	38
48	122	38
	123	38
	124	39
49	125	39
	126	39
	127	40
50	128	40
	129	41
51	130	41
	131	41

Table 3-11: Timing Channels Map (Continued)

% Value	DMX	= Seconds
	132	42
52	133	42
	134	43
53	135	43
	136	43
	137	44
54	138	44
	139	45
55	140	45
	141	45
	142	46
56	143	46
	144	47
57	145	4
	146	4
	147	48
58	148	48
	149	49
59	150	49
	15	49
	52	50
60	153	50
	154	50
	155	51
61	156	51
	157	52
62	158	52
	159	52
	160	53
63	161	53
	162	54
64	163	54
	164	54
	165	55
65	166	55
	167	56
66	168	56
	169	56
	170	57
67	171	57
	172	58
68	173	58
	174	58
	175	59
69	176	59

Table 3-11: Timing Channels Map (Continued)

% Value	DMX	= Seconds
	177	59
	178	60
70	179	60
	180	65
71	181	65
	182	65
	183	70
72	184	70
	185	75
73	186	75
	187	75
	188	80
74	189	80
	190	8
75	191	8
	192	85
	193	90
76	194	90
	195	95
77	19	95
	97	95
	198	100
78	199	100
	200	110
79	201	110
	202	110
	203	120
80	204	120
	205	120
81	206	130
	207	130
	208	140
82	209	140
	210	140
	211	150
83	212	150
	213	160
84	214	160
	215	160
	216	170
85	217	170
	218	180
86	219	180
	220	180
	221	190

Table 3-11: Timing Channels Map (Continued)

% Value	DMX	= Seconds
87	222	190
	223	200
88	224	200
	225	200
	226	210
89	227	210
	228	210
	229	220
90	230	220
	231	230
91	232	230
	233	230
	234	240
92	235	200
	236	250
93	237	250
	238	250
	239	260
94	240	260
	241	270
95	242	270
	243	270
	244	280
96	245	280
	246	290
97	247	290
	248	290
	249	300
98	250	300
	251	310
99	252	310
	253	310
	254	310
100	255	Follows Cue Data

# Updating Software

---

## USB Download

To download files with a PC equipped with a Universal Serial Bus (USB) port, you need the VARI\*LITE® USB Luminaire Programming Kit (28.8500.0054).

The VARI\*LITE® USB Luminaire Programming Kit (28.8500.0054) includes:

- VARI\*LITE® USB Upload Cable (25.9600.0001)
- USB Luminaire Programming Kit CD (87.8500.0002)
- Instruction Sheet (02.8500.0100)
- VARI\*LITE® carry bag (07.5044.0005)

### Computer Requirements for the USB Luminaire Programming Kit

- PC running Windows® 98, 2000, XP, or Vista. Although the USB Luminaire Programming kit software is not directly compatible with Macintosh® computers, it does run with some Windows emulators.
- In addition to Windows, your computer must be running IE 5.01 or later, and Microsoft .NET Framework Version 3.5 (or later), which you can download from <http://www.microsoft.com> and search for .NET Framework downloads.
- An available USB 2.0 port on the PC

### USB VDownloader PC Program and .bin Luminaire Files

The USB VDownloader program and current .bin files are available from the Product Downloads page at [www.vari-lite.com](http://www.vari-lite.com). Instructions for installing the USB VDownloader program on your PC are also available on the Product Downloads page. Use the USB VDownloader program to transfer updated versions of the luminaire operating software (.bin files) from your PC to the luminaires.



## Transferring Software From Luminaire to Luminaire

It is possible to transfer specific software versions between luminaires. As in the case of installing new software versions, multiple luminaires can be programmed at the same time when they are data linked together (refer to “[Connecting Data and Power](#)” on page 18), however, only a maximum of 32 luminaires can be updated at once.

### Hardware Requirements

Data cables used in this process must have two twisted pairs and a shield. It is also recommended that cables meet all other USITT DMX specification requirements. Refer to “[Data Cables](#)” on page 11.

A termination connector is used in this process. Refer to “[Male Termination Connector](#)” on page 12 for more information regarding the construction of this connector.

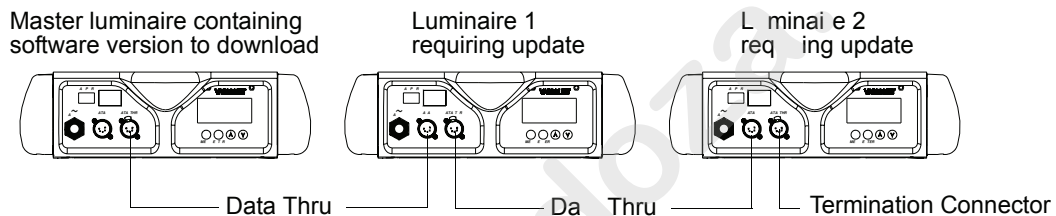

**Figure 3-4: Software Transfer Setup**

### Transfer Procedure

This procedure is used to transfer software versions between luminaires.

- Step 1. At last luminaire, install male termination connector into DATA THRU XLR connector.
- Step 2. At master luminaire (first in chain) Menu Display, press [Menu].
- Step 3. Press [Up] / [Down] arrows until Fixture appears.
- Step 4. Press [Up] / [Down] arrows until Download appears. Press [Enter].
- Step 5. OK? will be displayed. Press [Enter] to accept.
- Step 6. Download proceeds. (Download takes 4-5 seconds.) The number of blocks displayed is less in a luminaire-to-luminaire download than in a PC-to-luminaire download for the same software version.
- Step 7. When download is complete, luminaire automatically recalibrates. When recalibration is complete, luminaire is ready for operation with its new software version.

### Verify software version at luminaire:

- Step 1. At Menu Display, press [Menu].
- Step 2. Press [Up] / [Down] arrows until Fixture appears. Press [Enter].
- Step 3. Press [Up] / [Down] arrows until Version appears. Press [Enter].  
The first half of the version will be displayed as a date (MM.DD.YY). For example, 03.18.03 (March 18, 2003).  
Press [Up] / [Down] arrows to display second half of version. This will be displayed as a time (HH:MM). For example, 16:00

---

Notes

[www.carlosmendoza.com.mx](http://www.carlosmendoza.com.mx)



## **CHAPTER 4.**

# **Menu System**

This chapter contains instructions for operating the luminaire using the Menu Display feature.

- **Menu Operation**
- **Menu Functions**
- **Self-Tests**

# Menu Operation

## What Is the Menu System?

The menu system is a programmable set of commands used to configure, address, operate, and test the luminaire. The menu system is controlled at the Menu Display available at the enclosure input panel.

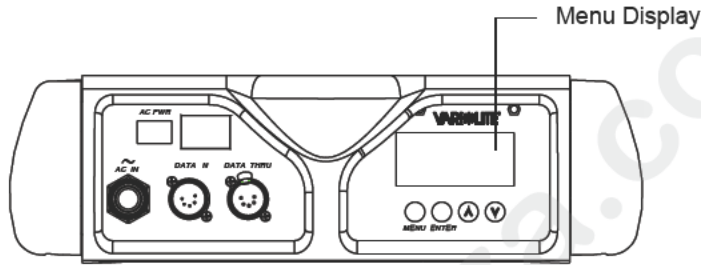

Figure 4-1: Menu Display Location

## Controls Operation

The menu system is controlled by four buttons. These buttons function as follows:

**[Menu] button.** Displays the menu, or if first level, the current address.

**[Enter] button.** Selects the current menu option or stores current data value.



**[Up] arrow.** Scrolls menu options upward or increases current data value. \*



**[Down] arrow.** Scrolls menu options downward or decreases current data value. \*

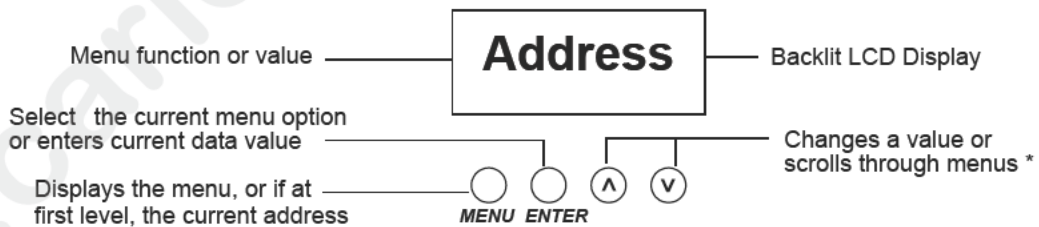

\* Arrows can be set to work in the hanging orientation. See **Disp Tilt** in the “Menu System Function Chart” on page 53. See also “Shortcuts” on page 51.

To enter the menu system, first press [Menu]. The functions displayed will be 1st level functions. Scroll through the 1st level functions by pressing [Up] / [Down] arrows. Once the desired function appears in the display, press [Enter]. You are now at the 2nd level. Once again, press the [Up] / [Down] arrows to scroll through 2nd level functions. Press [Enter] to access 3rd level functions and so forth. When the highest level for the function is reached, [Up] / [Down] arrows can be pressed to enter a value or select a toggle activation such as On/Off. Press [Enter] to store the value or select an action.

For example:

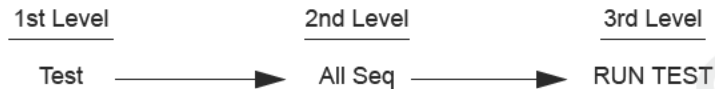

## Default State

The menu display's default state during normal operation is to display the DMX address. After 10 seconds of inactivity at the display, it will change to the default state.

After longer periods of inactivity, the menu display will switch to the off state. The default state for this feature is 5 minutes, however, different time lengths can also be programmed.

### To program a different time length for menu off state:

- Step 1. Press [Menu].
- Step 2. Press [Up] / [Down] arrows until Config (Configuration) appears. Press [Enter].
- Step 3. Press [Up] / [Down] arrows to access Display. Press [Enter].
- Step 4. Press [Up] / [Down] arrows to select either 30 Sec (30 seconds), 5 Min (5 minutes), 10 Min (10 minutes), or ON (on indefinitely). Press [Enter] to set.

## Shortcuts



### WARNING: Light Beam Projects Intense Heat

Do not illuminate objects within 3.5 m (11.5 feet) of the VL3500™ Wash Luminaire. Objects within this range can scorch, melt, or ignite from the heat projected by the light beam.

A few button combinations are provided as shortcuts for frequently used menu functions. These shortcuts are as follows:

- Pressing [Enter] and [Up] at the same time = Lamp On
- Pressing [Enter] and [Down] at the same time = Lamp Off
- Pressing [Up] and [Down] at the same time inverts or reverts the menu display (only if not set to Auto)
- Pressing [Menu] and [Up] at the same time = Recalibrate
- Pressing [Menu] at Power up interrupts calibration. See [“Program Starting Address Without Calibrating Luminaire”](#) on page 20 for more information.

# Menu Functions

## Menu System Overview

Representation of entire VL3500™ Wash Luminaire menu system.

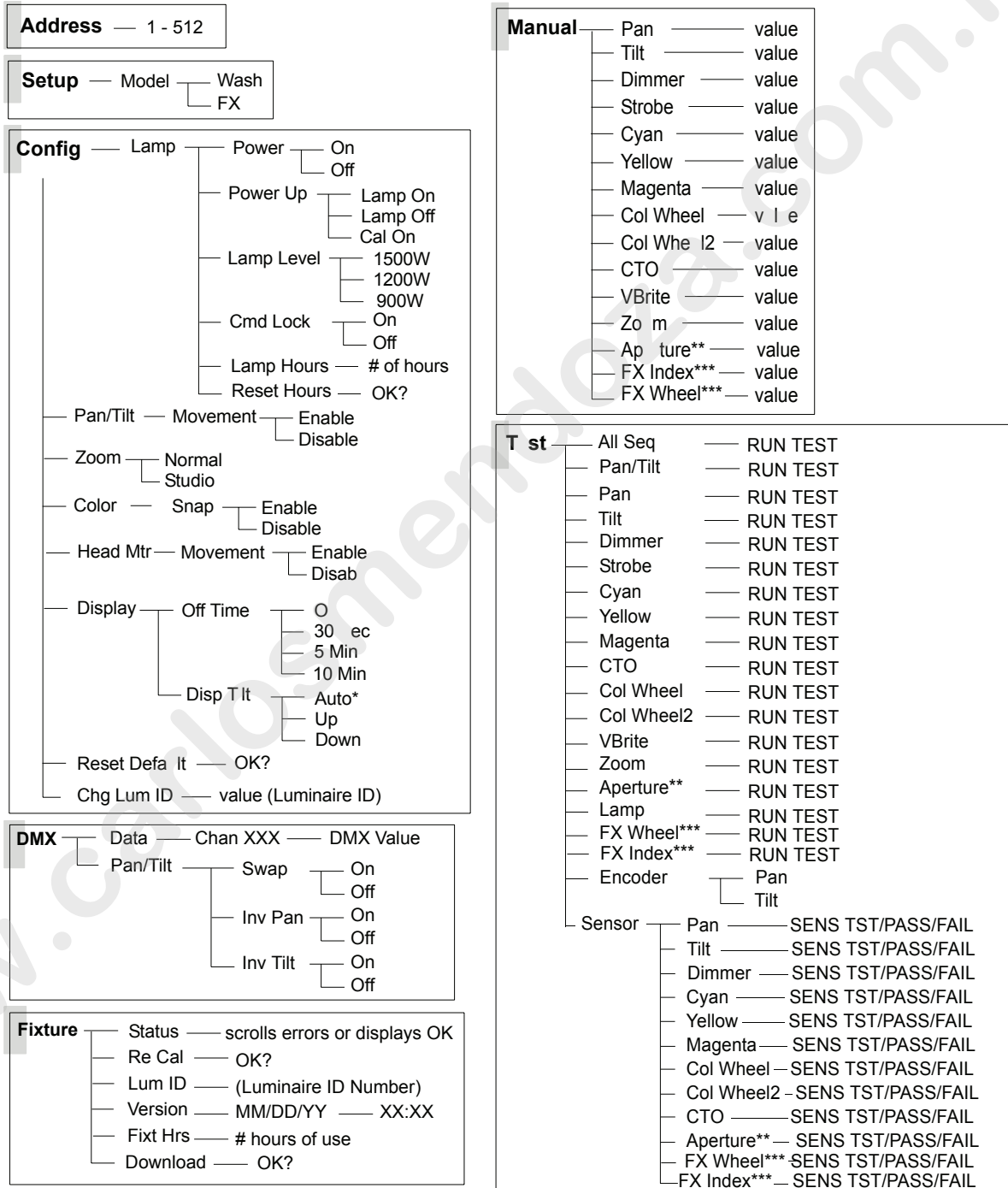

\* Only applies to displays manufactured before July 1, 2006.

\*\* VL3500 Wash only      \*\*\* VL3500 Wash FX only

## Menu System Function Chart

The following is a detailed look at the internal menu system.

**Table 4-1: VL3500™ Wash Luminaire Menu System Chart**

1st Level	2nd Level	3rd Level	4th Level	5th Level
<b>Address</b>	XXX value 1 thru 512			
<b>Setup</b>	<b>Model Luminaire Type</b>	<b>Wash</b>		
		<b>FX</b>		
<b>Config Configuration</b>	<b>LAMP Lamp Options</b>	<b>Power Lamp Power</b>	<b>ON</b> (default) <b>OFF</b>	
		<b>Power UP Lamp Power-up State</b>	<b>Lamp ON</b> Lamp On (default)	
			<b>Lamp OFF</b> Lamp Off	
			<b>Cal N</b> Lamp On After Calibration	
		<b>Lamp Level Lamp Power Level</b>	<b>1500W</b>	
			<b>1200W</b>	
			<b>900W</b>	
		<b>Cmd Lock</b> Prevent Remote Lamp Power-Level Changes From Console	<b>ON</b>	
			<b>Off</b>	
		<b>LampH</b> r Lamp Hours Used	<b>XXXX</b> Cumulative # of Lamp Hours	
	<b>Reset H</b> s Resets Lamp Hour	<b>OK?</b>		
	<b>Pan/Tilt</b> Pan and Tilt	<b>M</b> vement Position Recovery	<b>Enable</b> Enable	
			<b>Disable</b> Disable	
	<b>Zoom</b> Zoom lens	<b>Normal</b>		
		<b>Studio</b> Quiet Mode		
	<b>Color</b>	<b>Snap</b>	<b>Enable</b> Enable	
			<b>Disable</b> Disable	
	<b>Head M</b>	<b>Movement</b>	<b>Enable</b> Enable	
			<b>Disable</b> Disable	
	<b>D</b> isplay Display Illumination	<b>Off Time</b>	<b>ON</b> On indefinitely	
			<b>30 Sec</b> Off in 30 seconds	
			<b>5 Min</b> Off in 5 minutes	
			<b>10 Min</b> Off in 10 minutes	
<b>Disp Tilt</b>		<b>Auto*</b>		
		<b>Up</b>		
		<b>Down</b>		
<b>Reset Default</b>	<b>OK?</b>			
<b>Chg Lum ID</b> Change Luminaire ID	<b>XXXX</b> Value (Luminaire ID)			

Table 4-1: VL3500™ Wash Luminaire Menu System Chart

1st Level	2nd Level	3rd Level	4th Level	5thLevel
<b>DMX</b> DMX Data	<b>DATA *</b>	Chan XXX DMX Channel	XXXX Value 0 - 255	
	<b>Pan/Tilt</b> Pan and Tilt Options	<b>Swap</b> Swap Pan & Tilt	ON	
			OFF	
		<b>Inv Pan</b> Invert Pan	ON	
			OFF	
	<b>Inv Tilt</b> Invert Tilt	ON		
		OFF		
<b>Fixture</b>	<b>Status</b> Status/Error Display	Scrolls error messages or displays <b>OK</b>		
	<b>Re Cal</b> Recalibrate	<b>OK?</b>		
	<b>Lum ID</b> Luminaire ID	XXXXXXXX Luminaire ID Number		
	<b>Version</b> Version	MM/DD/YY (Page 1)	HH:MM (Page 2)	
	<b>Fixt Hrs</b> Fixture Hours	XXXX # Number of Fixture Hours		
	<b>Download</b> Download Software	<b>OK?</b>		
<b>Manual</b> Manual Commands (Disabled when DMX Present.)	<b>Pan *</b>	XXXX DMX Value		
	<b>Tilt *</b>	XXXX DMX Value		
	<b>Dimmer</b>	XXX DMX Value		
	<b>Strobe</b>	XXX DMX Value		
	<b>Cyan</b>	XXX DMX Value		
	<b>Yellow</b>	XXX DMX Value		
	<b>Magenta</b>	XXX DMX Value		
	<b>Col Wheel</b> Color Wheel 1	XXX DMX Value		
	<b>Col Wheel2</b> Color Wheel 2	XXX DMX Value		
	<b>CTO</b> Color Temperature Orange	XX DMX Value		
	<b>VBrite</b> VARI*BRITE le	XXX DMX Value		
	<b>Zoom</b>	XXX DMX Value		
	<b>Aperture</b> (Wash Only)	XXX DMX Value		
	<b>FX Wheel</b> (Wash FX Only)	XXX DMX Value		
	<b>FX Index</b> (Wash FX Only)	XXX DMX Value		



Table 4-1: VL3500™ Wash Luminaire Menu System Chart

1st Level	2nd Level	3rd Level	4th Level	5thLevel	
Test	All SEQ <i>Test all mechanisms in order, X steps.</i>	RUN TEST <i>Run-Test in Progress</i>	Press [Menu] to stop tests		
	Pan/Tilt	RUN TEST <i>Run-Test in Progress</i>			
	Pan	RUN TEST <i>Run-Test in Progress</i>			
	Tilt	RUN TEST <i>Run-Test in Progress</i>			
	Dimmer	RUN TEST <i>Run-Test in Progress</i>			
	Strobe	RUN TEST <i>Run-Test in Progress</i>			
	Cyan	RUN TEST <i>Run-Test in Progress</i>			
	Yellow	RUN TEST <i>Run-Test in Progress</i>			
	Magenta	RUN TEST <i>Run-Test in Progress</i>			
	CTO	RUN TEST <i>Run-Test in Progress</i>			
	Col Wheel	RUN TEST <i>Run-Test in Progress</i>			
	Col Wheel2	RUN TEST <i>Run-Test in Progress</i>			
	VBrite	RUN TEST <i>Run-Test in Progress</i>			
	Zoom	RUN TEST <i>Run-Test in Progress</i>			
	Aperture (Wash Only)	RUN TEST <i>Run-Test in Progress</i>			
	Lamp <i>Disables Pan/Tilt and Sets Intensity to Full.</i>	RUN TEST <i>Run-Test in Progress</i>			
	FX Wheel (Wash FX Only)	RUN TEST <i>Run-Test in Progress</i>			
	FX Index (Wash FX Only)	RUN TEST <i>Run-Test in Progress</i>			
	Encoder	Pan		XXXX Value	
		Tilt		XXXX Value	
	Sensor	Pan		SENS TST Sensor	PASS/FAIL
		Tilt		SENS TST Sensor	PASS/FAIL
		Dimmer		SENS TST Sensor	PASS/FAIL
		Cyan		SENS TST Sensor	PASS/FAIL
		Yellow		SENS TST Sensor	PASS/FAIL
		Magenta		SENS TST Sensor	PASS/FAIL
		Col Wheel Color Wheel 1		SENS TST Sensor	PASS/FAIL
Col Wheel2 Color Wheel 2			SENS TST Sensor	PASS/FAIL	
CTO Color Temperature Orange			SENS TST Sensor	PASS/FAIL	
Aperture (Wash Only)			SENS TST Sensor	PASS/FAIL	
FX Wheel (Wash FX Only)			SENS TST Sensor	PASS/FAIL	
FX Index (Wash FX Only)			SENS TST Sensor	PASS/FAIL	

\* For 16-bit parameters, the data displayed will be scaled to a range of 0-4095.

## Menu Function Definitions

For easy reference, each possible menu item is listed alphabetically in the first column by its display abbreviation. The second column follows with a definition of the abbreviation and then a third column provides an explanation of its purpose and function.

**Table 4-2: Menu Function Definitions**

Display	Definition	Purpose
10 Min	10 Minutes	Sets Menu Display to automatically shut off after 10 minutes of non-use.
30 Sec	30 Seconds	Sets Menu Display to automatically shut off after 30 seconds of non-use.
5 Min	5 Minutes	Sets Menu Display to automatically shut off after 5 minutes of non-use.
Address	Address	Accesses option for setting luminaire DMX starting address.
All SEQ	All Sequence	Tests all internal mechanisms in sequence for X steps.
Aperture	Aperture	Sets aperture opening positions and test aperture function.
Cal ON	Calibration On	Configures arc luminaire so that lamp will strike after calibration.
Channel XXX	DMX Channel	Specifies DMX channel for display of current data value. (Only for channels the luminaire is occupying).
Chg Lum ID	Change Luminaire ID	Normally set to luminaire serial number.
Cmd Lock	Remote Lamp-Level Command Lock	Denies (lock <b>On</b> ) or allows (lock <b>Off</b> ) remote lamp power-level changes from the console. When Lamp Level is set to <b>1500W</b> , <b>1200W</b> , or <b>900W</b> , Cmd Lock <b>On</b> locks that power-level setting at the luminaire and any attempt to change the power-level setting from the console is ignored.
Col Wheel	Color Wheel 1	Specifies color wheel for manual control ( <b>Manual</b> ) or testing ( <b>Test</b> ).
Col Wheel2	Color Wheel 2	Specifies color wheel for manual control ( <b>Manual</b> ) or testing ( <b>Test</b> ).
Config	System Configuration	Accesses options for setting lamp, pan/tilt, and Menu Display defaults. Also accesses lamp information such as number of hours used, along with its respective reset function.
CTO	CTO Function	Specifies CTO (color temperature orange) parameter for manual control ( <b>Manual</b> ) or testing ( <b>Test</b> ).
Cyan	Cyan	Specifies cyan color parameter for manual control ( <b>Manual</b> ) or testing ( <b>Test</b> ).
Data	DMX Data	Allows viewing of DMX on given channel.
Dimmer	Dimmer	Specifies dimmer mechanism for manual control ( <b>Manual</b> ) or testing ( <b>Test</b> ).
Disable	Disable	Disables a function.
Displa	Display	Accesses options for Menu Display illumination time and orientation.
Disp Tilt	Menu orienta- tion control	Sets the orientation of the menu display to match the luminaire orientation, either standing ( <b>Up</b> ) or hanging ( <b>Down</b> ). The <b>Auto</b> setting is functional only for display boards manufactured prior to 01 July 2006.
DMX	DMX	Accesses options for DMX system settings.
Download	Download	Initiates download of luminaire software.
Enable	Enable	Enables a function.
Encoder	Encoder	Accesses pan/tilt encoders for diagnostic testing.
FAIL	Test Fail	Indicates that a test has failed.
Fixt Hrs	Fixture Hours	Displays total number of hours luminaire has been powered on.

Table 4-2: Menu Function Definitions (Continued)

Display	Definition	Purpose
Fixture	Fixture	Accesses luminaire information such as serial number, software version, and total operation hours. Also accesses recalibration and download options.
FX Wheel	FX Wheel	Specifies FX wheel for manual control ( <b>Manual</b> ) or testing ( <b>Test</b> ).
FX Index	FX Wheel	Specifies FX index function for manual control ( <b>Manual</b> ) or testing ( <b>Test</b> ).
Head Mtr	Head Motor	Enables or disables pan/tilt movement.
Inv Pan	Invert Pan	Reverses pan action for special focus requirements.
Inv Tilt	Invert Tilt	Reverses tilt action for special focus requirements.
Lamp	Lamp	Accesses lamp power-up options, reset and information ( <b>Con g</b> ) or tests Lamp function ( <b>Test</b> ).
Lamp Hours	Lamp Hours	Displays total number of lamp operating hours.
Lamp Level	Lamp Power Level	Displays lamp power levels: <b>1500W</b> , <b>1200W</b> , r <b>900W</b> .
Lamp OFF	Lamp is Off	Configures arc luminaire so that lamp will not strike upon power up.
Lamp ON	Lamp is On	Configures arc luminaire so that lamp will strike upon power up.
Lum ID	Luminaire ID	Displays unique luminaire ID number.
Magenta	Magenta	Specifies magenta parameter for manual control ( <b>Manual</b> ) or testing ( <b>Test</b> ).
Manual	Manual	Accesses options for luminaire mechanism control by entry of data values.
Movement	Movement	Enables or disables pan and tilt movement.
Normal	Zoom Mode	Zoom configurations in normal mode.
OFF	Off	Turns off a function.
Off Time	Display off time	Shows the automatic shut-off time for the menu display.
OK	Okay	Indicates calibration has completed and no errors have occurred.
OK?	Okay?	Prompt for pressing [Enter] before an action is executed.
ON	On Indefinitely	Set Menu Display to stay on until programmed otherwise ( <b>Display</b> ) or turns on a function.
Pan	Pan	Specifies pan function for manual control ( <b>Manual</b> ) or testing ( <b>Test</b> ).
Pan/Tilt	Pan/Tilt	Accesses pan and tilt options for focus swap function, movement enable/disable, manual control and testing.
PASS	Test Pass	Indicates that a test has passed.
Power	Lamp Power	Accesses options to turn lamp on or off.
Power Up	Power Up	Accesses options for lamp power up state.
PRO	Programming	Currently programming the new version of software.
Re Cal	Recalibrate	Recalibrates luminaire.
Reset Default	Reset Defaults	Resets default system configuration values.
Reset Hours	Reset Lamp Hours	Resets lamp hour and strike counters. (For use when new lamp is installed.)
RUN TEST	Run Test	Indicates that a mechanism test is in progress.
Sensor	Sensors	Accesses sensor types for diagnostic testing.
Setup	Setup	Configures luminaire as Wash or Wash FX.
Status	Status/Error	Allows scrolling through error list or displays <b>OK</b> if no errors.
Strobe	Strobe	Specifies strobe function for manual control ( <b>Manual</b> ) or testing ( <b>Test</b> ).

Table 4-2: Menu Function Definitions (Continued)

Display	Definition	Purpose
STST	Sensor Test	Indicates that a system sensor test is in progress.
Studio	Zoom Mode	Zoom configuration is in quiet mode for studio use.
Swap	Swap	Swaps pan/tilt action for special focus requirements.
Test	Test	Accesses diagnostic tests for internal mechanisms.
Tilt	Tilt	Specifies tilt function for manual control ( <b>Manual</b> ) or testing ( <b>Test</b> )
Version	Version	Displays current software version date and time (in two pages)
VBrite	VARI* <i>BRITE</i>	Controls split lens assembly.
Yellow	Yellow	Specifies yellow color parameter for manual control ( <b>Manual</b> ) or testing ( <b>Test</b> ).
Zoom	Zoom Function	Specifies zoom function for manual control ( <b>Manual</b> ) or testing ( <b>Test</b> ).
Zoom	Zoom Config	Specifies zoom configuration mode ( <b>Normal</b> ) or ( <b>Studio</b> ).

## Self-Tests

### Running Parameter Tests

The luminaire is capable of running self-tests by using the Test menu functions.

When running tests on multiple luminaires, a male termination connector is required at the last luminaire in the link. Refer to “[Connecting Data and Power](#)” on page 18 for more information regarding the construction of this connector.



**Note:** After 10 seconds of inactivity, the menu display changes to the default state showing the address.

#### To connect luminaires for simultaneous testing:

- Step 1. At last luminaire, install male termination connector in o DATA THRU XLR connector.
- Step 2. At master luminaire Menu Display, press [Menu].

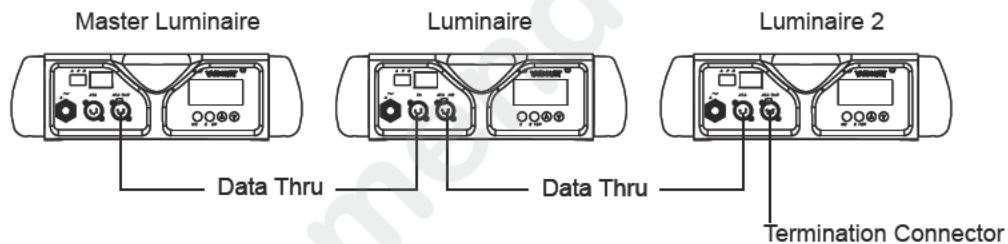

Figure 4-2: Testing Setup



#### WARNING: Light Beam Projects Intense Heat

Do not illuminate objects within 3.5 m (11.5 feet) of the VL3500™ Wash Luminaire. Objects within this range can scorch, melt, or ignite from the heat projected by the light beam.

#### To run tests:

- Step 1. Press [Menu].
- Step 2. Press [Up] / [Down] arrows until Test appears. Press [Enter].
- Step 3. Use [Up] / [Down] arrows to select a parameter to test. Refer to “[Menu System Function Chart](#)” on page 53 for a complete list of test parameters which can be chosen.
- Step 4. Press [Enter] to run test.
- Step 5. Press [Menu] to stop test at any time.

### **Movement Disable**

The Movement option allows pan and tilt to be disabled so that the luminaire can be placed in any position for testing without movement occurring. In order to regain full control of the luminaire, Movement will need to be enabled after testing.



**Note:** When using the Movement option, pan and tilt will be disabled for all the luminaires that are linked.

---

#### **To set movement option:**

- Step 1. Press [Menu].
- Step 2. Press [Up] / [Down] arrows until **Config** appears. Press [Enter].
- Step 3. Press [Up] / [Down] arrows until **Pan/Tilt** appears. Press [Enter].
- Step 4. **Movement** will be displayed. Press [Enter].
- Step 5. Use [Up] / [Down] arrows to select **Enable** or **Disable**. Press [Enter] to select.

## APPENDIX A.



# Troubleshooting and Maintenance

This appendix provides instructions for troubleshooting and routine maintenance which may be necessary during the life of the luminaire.

- **Troubleshooting**
- **Routine Maintenance**



---

---

**WARNING:** All maintenance procedures are to be performed with power removed from the luminaire. Never remove covers or backcap while lamp is in operation. Wear eye protection when opening backcap and replacing lamps.

---

---

# Troubleshooting

---

## Error Messages

If a problem occurs during luminaire calibration, at the end of the calibration sequence the Menu Display cycles through any applicable error message(s) until the end of the list is reached. To review the error messages again, re-access them using the Status function.

**To access error messages:**

- Step 1. Press [Menu].
- Step 2. Press [Up] / [Down] arrows until Fixture appears. Press [Enter].
- Step 3. Press [Up]/ [Down] arrows to access Status. Press [Enter]. (Display will now scroll through any error messages or display OK if no errors.)

**Table A-1: Error Message**

Display	Message
OK	No error found
Pan / No Sens	Pan sensor not found
Pan / Encoder / Fail	Pan encoder failure
Tilt / No Sens	Tilt sensor not found
Tilt / Encoder / Fail	Tilt encoder failure
Dimmer / No Sens	Dimmer sensor not found
Cyan / No Sens	Cyan sensor not found
Yellow / No Sens	Yellow sensor not found
Magenta / No Sens	Magenta sensor not found
ColWheel / No Sens	Color wheel sensor not found
ColWheel2 / No Sens	Color wheel sensor not found
CTO / No Sens	CTO sensor not found
Indx / No Sens	Index sensor not found
FX / No Sens	FX wheel sensor not found



## Routine Maintenance

### Lamp Replacement

Tools: #2 Phillips screwdriver and lint-free cotton gloves



**WARNING:** Ensure that power is removed from luminaire when installing lamp. Always wear eye protection when opening lamp box and replacing lamps.



**CAUTION:** Wear cotton gloves or other covering while installing lamp. Touching lamp glass with bare fingers will leave oil and can cause the lamp to explode or reduce lamp life. If touched, use alcohol and cotton cloth to thoroughly clean glass portion of lamp.

#### To replace lamp:

- Step 1. Remove power from luminaire and allow unit to cool.
- Step 2. At rear of luminaire head, loosen four 1/4 turn screws and slide hinged lamp box back and out.
- Step 3. Remove current lamp.
- Step 4. Position new lamp with dimple side towards lamp socket. Insert lamp in connector. Ensure lamp is fully seated in place.
- Step 5. Close lamp box and retighten 1/4-turn screws.
- Step 6. Align lamp as detailed in ["Align Lamp"](#) on page 64.



**CAUTION:** Allow lamp cool before servicing.



**CAUTION:** Do not touch lamp or reflector with bare fingers.

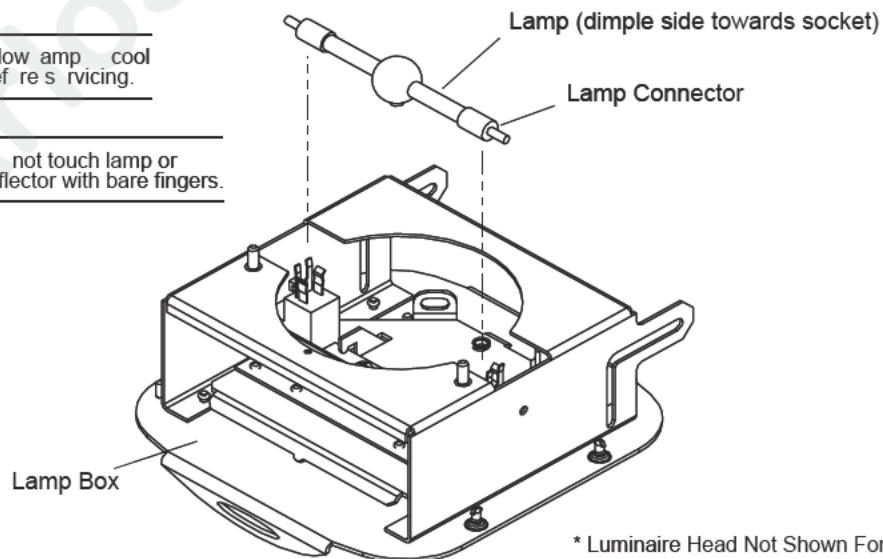

Figure A-1: Lamp Replacement

## Align Lamp

After a new lamp is installed, the lamp must be aligned to optimize the beam. Whenever a lens is changed, lamp alignment can also be beneficial. Adjustment knobs are located on the backcap.



**WARNING:** Backcap and adjustment knobs are HOT during lamp operation. Wear gloves to prevent burns.



**WARNING: Light Beam Projects Intense Heat**

Do not illuminate objects within 3.5 m (11.5 feet) of the VL3500™ Wash Luminaire. Objects within this range can scorch, melt, or ignite from the heat projected by the light beam

**To align lamp:**

- Step 1. Power-up luminaire.
- Step 2. At Menu Display, select Lamp from Conf g m nu ( refer to “Menu Operation” on page 50). (If using console, set intensity to 100% and s t VARI\*BRITE™ mode to open.)
- Step 3. Position beam on a white wall at a distance of 12 to 20 feet.
- Step 4. At backcap, using X, Y, and Z adjus ment screws, adjust beam as required. For true Z adjustment, turn all three knobs equally.

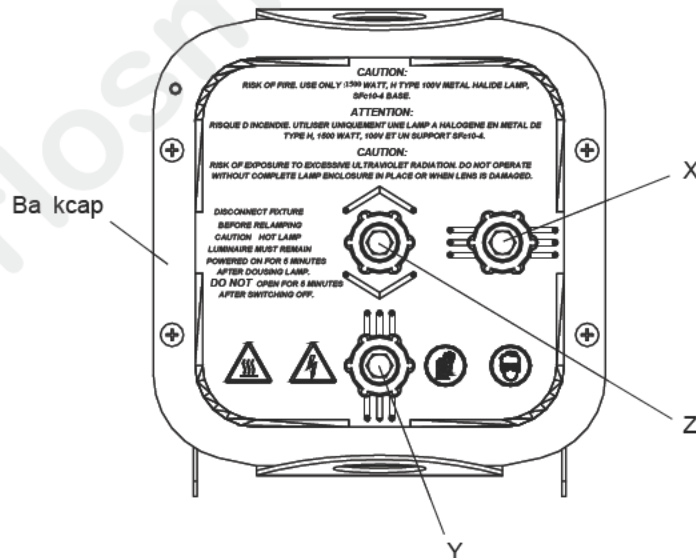

Figure A-2: Aligning Lamp

---

## Internal Lens Replacement

**Tools:**

- #2 Phillips screwdriver
- Lint-Free Cotton Gloves

**To replace the internal lens assembly:**

Step 1. Using control console, set the VARI\*BRITE mode to closed. Move the internal lens assembly to front (zoom wide) of the head assembly (near luminaire front lens).



**WARNING:** Remove power from luminaire before performing maintenance. Internal fixture components and assemblies can be HOT after operation. Allow to adequately cool before replacing.

---

---

Step 2. Remove power from luminaire and allow unit to cool.

Step 3. As shown in [Figure A-3](#), remove appropriate head cover by loosening four 1/4-turn screws.



**CAUTION:** Wear cotton gloves or other covering when replacing. Clean any fingerprints or debris from lenses with isopropyl alcohol and soft cloth if required.

---

Step 4. At the internal lens assembly, remove the two retaining knobs and the cross strap that secure the lens.

Step 5. Slide each side of lens assembly straight up, and off its respective post.

Step 6. Slide replacement lens assembly onto its post.



**CAUTION:** As shown in **Detail A** in [Figure A-3](#), insure that the lens assembly is aligned and fits properly into keyed carrier.

---

Step 7. Secure lens assembly by replacing the cross strap and retaining knobs. Hand tighten only.

Step 8. Replace head cover.

Step 9. Power luminaire and test.

## Internal Lens Replacement (continued)

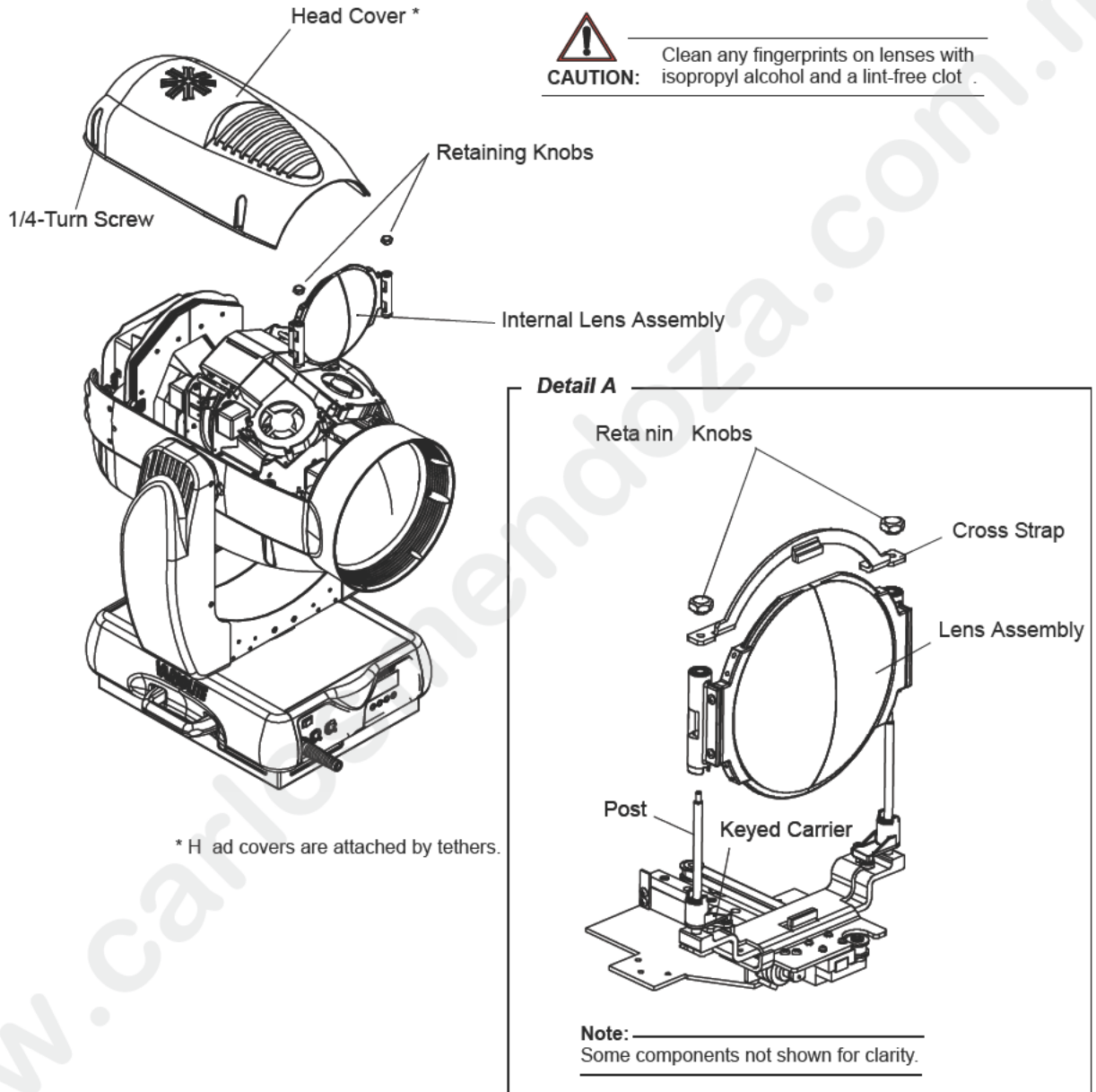

Figure A-3: Internal Lens Replacement

## Front Lens Assembly Removal

### Tools:

- 5/32" Allen wrench
- Lint-Free Cotton Gloves

### To replace the front lens assembly:



**WARNING:** Remove power from luminaire before performing maintenance. Internal fixture components, assemblies and the front lens can be HOT after operation. Allow items to adequately cool before replacing.

Step 1. Remove power from luminaire.



**CAUTION:** The luminaire head is a precisely balanced unit. The weight of the front lens assembly is counter-balanced inside the head. Removal of the front lens assembly can result in instantaneous uncontrolled head movement. To avoid uncontrolled movement when the luminaire is sitting on upper enclosure, point the head straight up. To avoid uncontrolled movement when the luminaire is hanging, point the head up at an angle until it rests against the tilt stops as shown here.

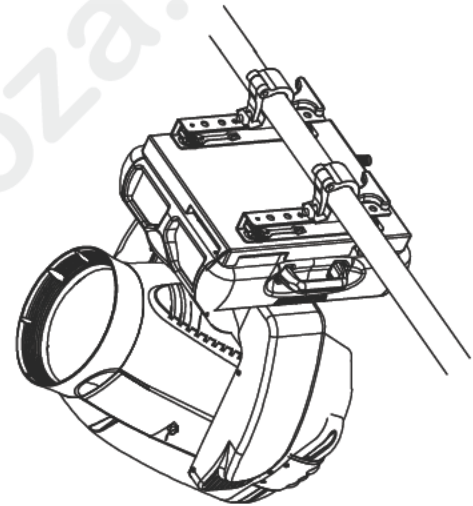

Step 2. Tilt the head to avoid uncontrolled movement. As shown in [Figure A-3](#), remove front lens assembly by loosening four captive screws.



**CAUTION:** When handling the front lens assembly, wear cotton gloves or other covering. If needed, clean any fingerprints or debris from lenses with isopropyl alcohol and soft cloth.

Step 3. Carefully position replacement front lens assembly so captive screws align with guide pins and mounting holes as illustrated in [Figure A-4](#).

Step 4. Tighten each captive screw to secure front lens assembly to luminaire head.

Step 5. To optimize beam, align lamp as described in “Align Lamp” on page 64.

Step 6. The luminaire is now ready for operation.

## Front Lens Assembly Removal (continued)

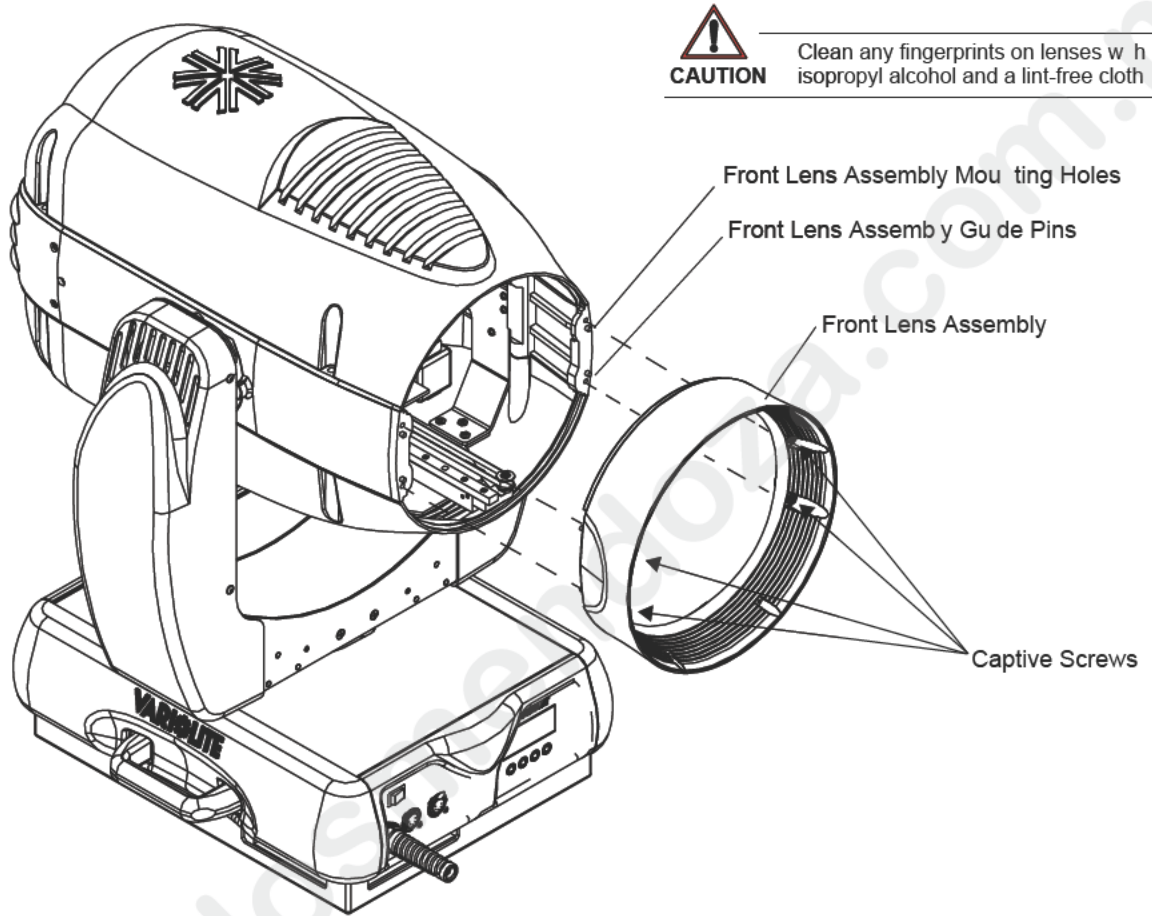

Clean any fingerprints on lenses with isopropyl alcohol and a lint-free cloth



Lens is heavy. Horizontal orientation shown for clarity. If lens is removed as shown, head assembly will instantaneously rotate to face upwards. See Caution on [page 67](#).

Figure A-4: Front Lens Assembly Removal

---

## Color Filter Replacement

Tools:

- lint-free cotton gloves
- #2 Philips screwdriver



**WARNING:** Remove power from luminaire before performing maintenance. Filters can be HOT after operation. Allow the fixture to cool before replacing filters.

---

---

### To replace a color filter on Color Wheel 1 (closest to the lamp):

- Step 1. Remove power from luminaire.
- Step 2. Remove bottom (relative to backcap label) head cover by loosening the four 1/4-turn screws.
- Step 3. As shown in [Figure A-5](#), open door on the cooling-air duct.



**CAUTION:** Do not touch filters with bare fingers. Wear cotton gloves or other covering while replacing filters. To clean filters, use isopropyl alcohol and soft cloth. Strong cleaning solutions can damage coating. Fingerprints or other grease deposits on filters can cause the glass to break.

---

- Step 4. Rotate Color Wheel 1 until the filter you are changing is accessible.
- Step 5. To improve access to the filter, rotate the mixed color wheels to position the cut-outs next to the filter you are changing.
- Step 6. Gently press the color filter toward the lamp until it is free of the lock pins. Remove filter.
- Step 7. Orienting coated side of filter towards lamp, slide new filter under the spring clip until it is securely retained by the lock pins.
- Step 8. Close the air-duct door. Replace the head cover.

### To replace a color filter on Color Wheel 2 (closest to the lens):

- Step 1. Remove power from luminaire.
- Step 2. Remove top (relative to backcap label) head cover by loosening the four 1/4-turn screws.



**CAUTION:** Do not touch filters with bare fingers. Wear cotton gloves or other covering while replacing filters. To clean filters, use isopropyl alcohol and soft cloth. Strong cleaning solutions can damage coating. Fingerprints or other grease deposits on filters can cause the glass to break.

---

- Step 3. Rotate Color Wheel 2 until the filter you are changing is accessible.
- Step 4. To improve access to the filter, rotate the mixed color wheels to position the cut-outs next to the filter you are changing.
- Step 5. As shown in [Figure A-5](#), gently press the color filter toward the lens until it is free of the lock pins. Remove the filter.

## Color Filter Replacement (continued)

- Step 6. Orienting coated side of filter towards lamp, slide new filter under the spring clip until it is securely retained by the lock pins.
- Step 7. Replace the head cover.

Assembly With Color Wheels  
(Do not remove. See detail)

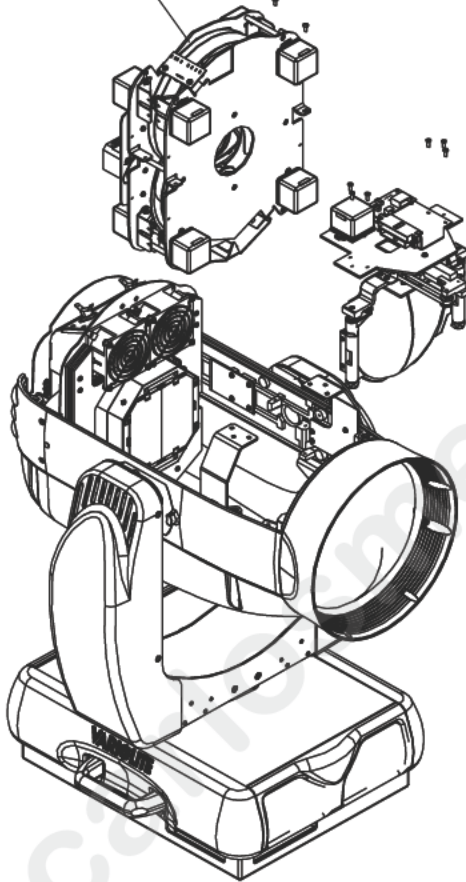

**CAUTION:** Do not touch filters with bare fingers. Wear cotton gloves

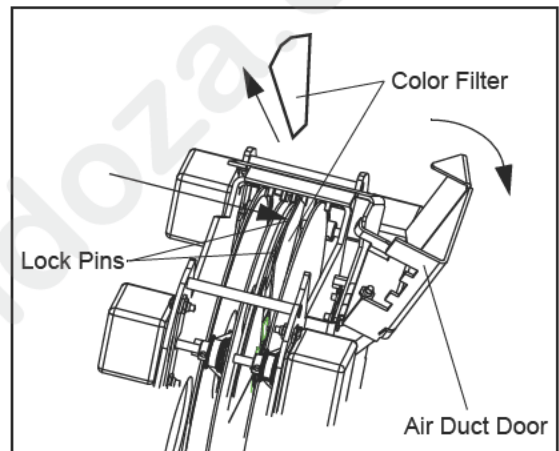

Color Wheel 1

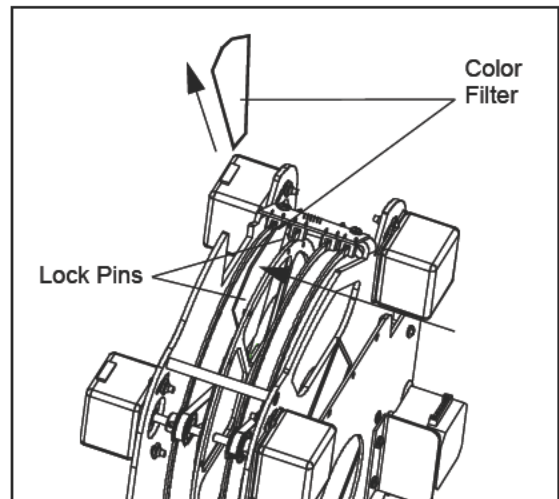

Color Wheel 2

Figure A-5: Replacing a Color Filter



---

**FX Pattern Replacement (VL3500 Wash FX Only)**

---



**WARNING:** Remove power from luminaire before performing maintenance. Patterns can be HOT after operation. Allow the fixture to cool before removing patterns.

---

---



**WARNING:** Users of VARI\*LITE® luminaires should not install or use metal effects patterns or gobos. The use of metal effects patterns or gobos in any VARI\*LITE® product may damage the luminaire and could void the luminaire's warranty.

---

---

**Tools:**

Screwdriver, Phillips #2  
Cotton gloves

**To remove and replace an effects pattern on rotating effects wheel 1:**

Step 1. Remove power from luminaire.

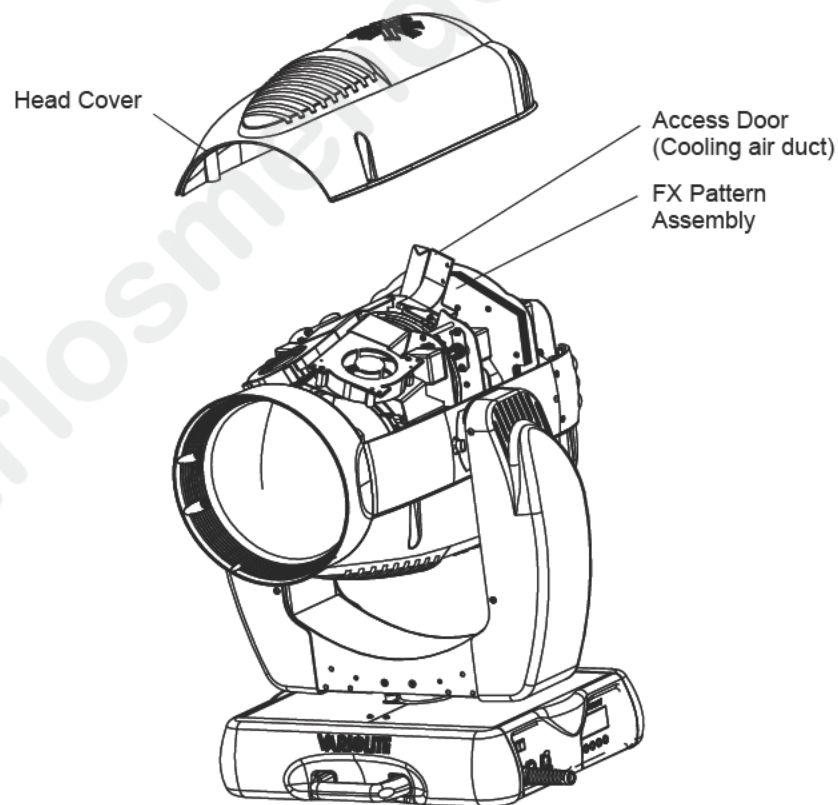

**Figure A-6: VL3500 Wash FX Pattern Replacement**

Step 2. Remove head cover by loosening the four 1/4-turn screws.

Step 3. As shown in [Figure A-6](#), open door on the cooling-air duct.



---

**CAUTION:** Do not touch patterns with bare fingers. Wear cotton gloves or other covering while replacing or cleaning patterns. To clean patterns, use isopropyl alcohol and soft cloth.

---

- Step 4. Rotate Yellow Wheel until cut-out faces up.
- Step 5. Rotate Effects Pattern Wheel to desired pattern.
- Step 6. At pattern's planet gear, gently rotate two planet gear latches that secure pattern planet gear.
- Step 7. Remove planet gear containing the pattern from assembly.
- Step 8. If replacing pattern, perform the following, if not proceed to Step 9.
  - a. At planet gear, rotate retaining spring from assembly.
  - b. Gently press pattern out from planet gear.
  - c. Install new pattern in same orientation (including black side up in the gear as shown in [Figure A-7](#) - reflective side must face lamp). This ensures all will calibrate in the same orientation.



---

**Note:** If installing same pattern in multiple fixtures, utilize same orientation (in relation to the planet gear) in all fixtures.

---

- d. Use care in reinstalling retaining spring. Spring can scratch pattern.
- Step 9. Rotate rotating effects wheel until you see the small indexing hole in the sun gear.
- Step 10. When reinstalling planet gear assembly, you must align the index mark in the planet gear with the index mark (small indexing hole) in sun gear. Install pattern.
- Step 11. Reengage two retaining latches. Ensure the latches are properly (and equally) positioned over neighboring planet gear assemblies.
- Step 12. Close the air-duct door.
- Step 13. Replace bottom hatch cover.

# FX Pattern Replacement (VL3500 Wash FX Only) (continued)

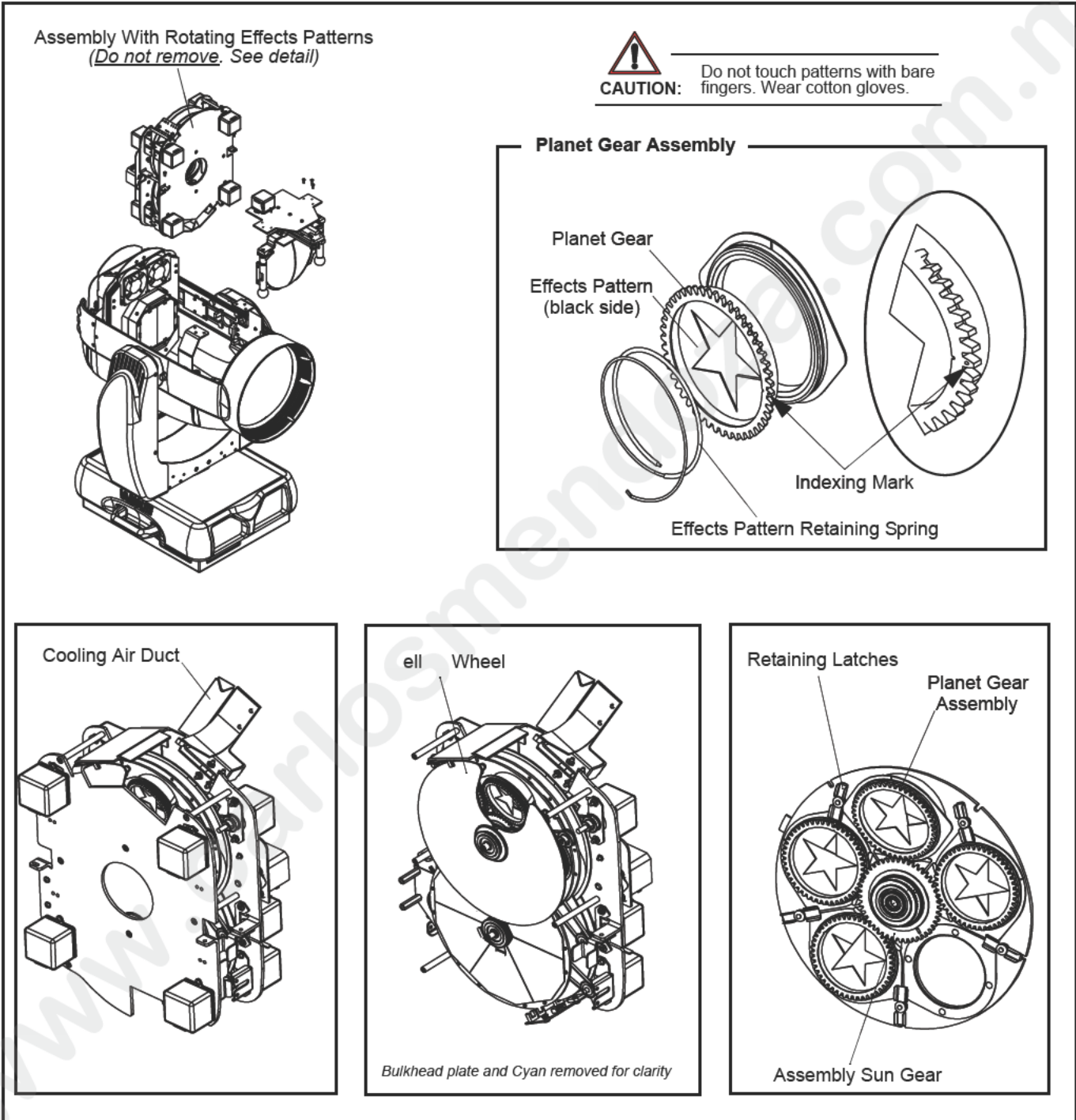

Figure A-7: FX Pattern Replacement (VL3500 Wash FX Only)

## Cleaning Front Lens

The front lens can be cleaned using isopropyl alcohol and a soft, lint-free cloth. In the event that the front lens assembly needs to be removed for cleaning, refer to “[Front Lens Assembly Removal](#)” on [page 67](#) for removal procedure.

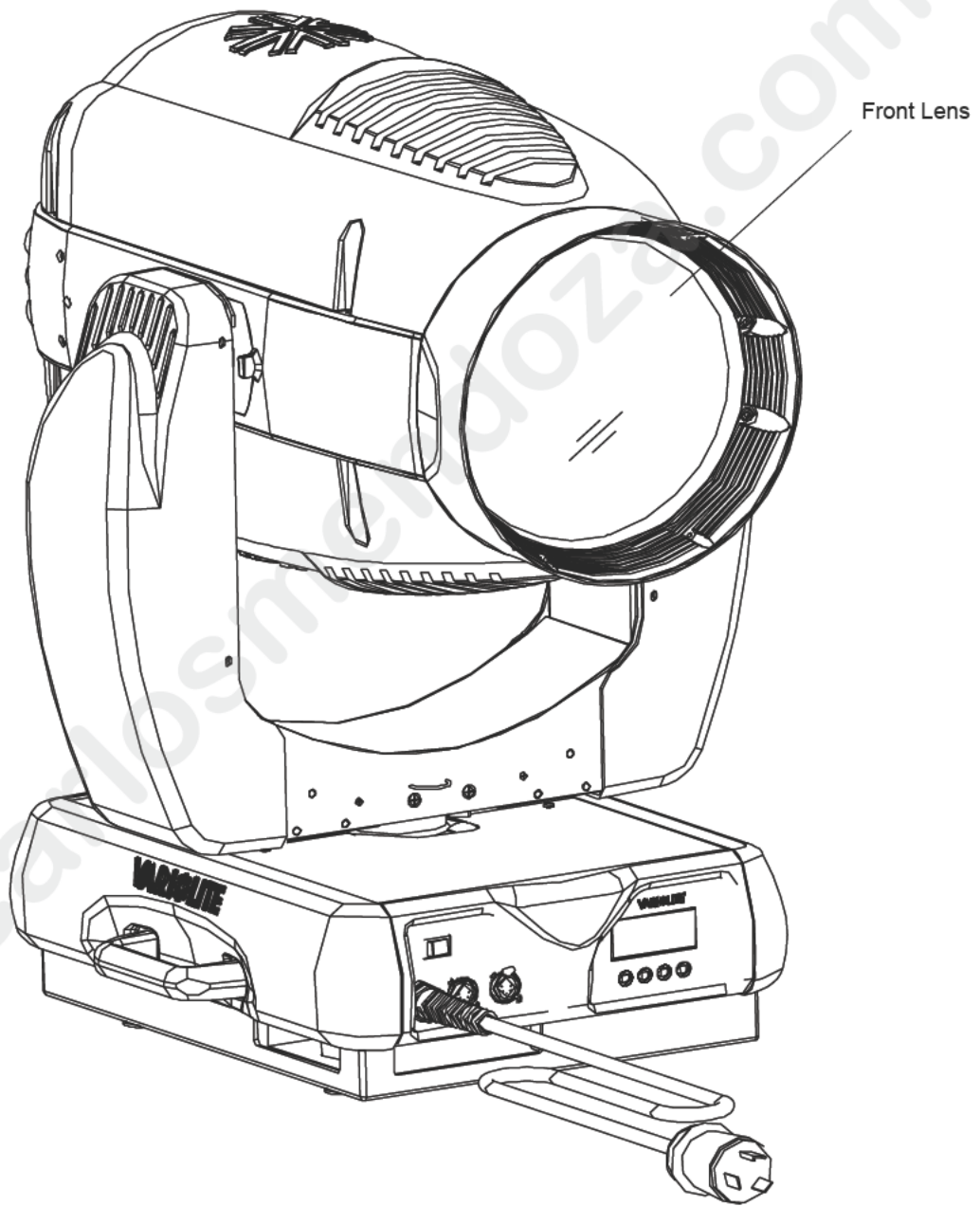

Figure A-8: Cleaning Front Lens

## ***APPENDIX B.***



# **Technical Specifications**

This appendix provides technical specifications and photometric information for all models of the luminaire.

- **Specifications**
- **Photometric Data: VL3500 Wash Luminaire**
- **Photometric Data: VL3500 Wash FX Luminaire**

# Specifications

---

## VL3500 Wash and VL3500 Wash FX Luminaires

### PROGRAMMABLE FUNCTIONS

#### Color System

A three-filter CYM cross-fading mechanism. Two fixed-color wheels each with six interchangeable color filter positions, one of which is open, and continuous wheel rotation for additional effects. The color system includes a variable CTO color temperature correction filter.

#### Beam Size Control

A zoomable beam spreader mechanism provides continuous beam size control for both rapid changes and smooth time beam angle changes.

#### Aperture Wheel (VL3500 Wash only)

An aperture wheel includes various opening diameters (aperture sizes: 25, 30, 35, 40, 52 mm) and can be rotated continuously to create effects.

#### Intensity Control

Full field dimming designed for both smooth timed fades and quick dimming effects.

#### Strobe

High-performance dual blades robe system capable of ultra-fast operation.

#### Pan and Tilt

Smooth, time-continuous motion using stepper motors with encoder correction. Pan range is 540°, Tilt range is 250° 0.3° resolution.

#### Rotating Effects Wheel (VL3500 Wash FX only)

One rotating FX pattern wheel with four rotatable and indexable positions and one open position.

### OPTICAL

#### Source

Olam SharXS® HTI® 1500 W/D7/60 metal halide lamp (part # 71.9686.1502)

#### Output

Over 50,000 lumens, dependent on the type of lens being used.

#### Reflector

Precision glass reflector with dichroic cold mirror coating.

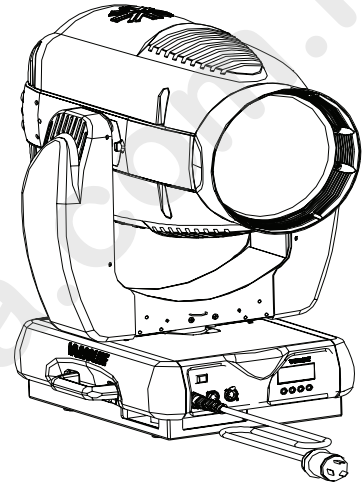

**FX Patterns (VL3500 Wash FX only)**

FX Patterns are 2.0 inches (50.8 mm) in diameter and 0.043 inches (1.1 mm) in thickness. (Metal patterns are not acceptable.)

**OPERATIONAL****Power Requirements**

Standard AC power distribution from 200-264 VAC, 50/60 Hz. The fixture requires 7 to 12 A depending on the AC supply voltage.

**Operational Temperature**

-20° to 104°F (-29° to 40°C)

**Cooling**

Forced air cooled.

**Control**

Compatible with a wide variety of DMX512 consoles.

**Weight**

VL3500 Wash Luminaire: 96 lbs. (43.5 kg) with rails

VL3500 Wash FX Luminaire: 97 lbs. (44.0 kg) with rails

**Spacing**

Hangs on 28.0 inch (71 cm) centers. All models can be mounted and operated in any orientation.

## Photometric Data: VL3500 Wash Luminaire

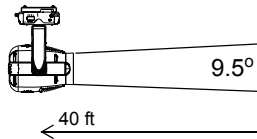
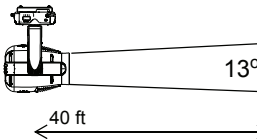
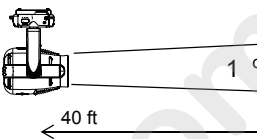
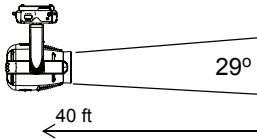
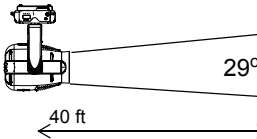
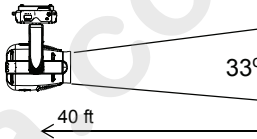
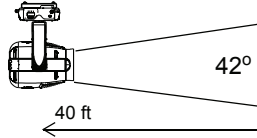
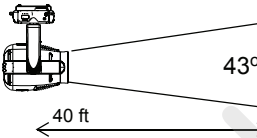
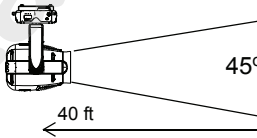
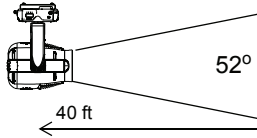
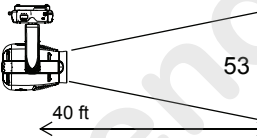
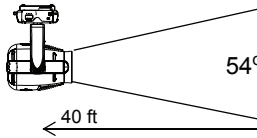
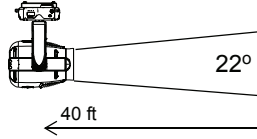
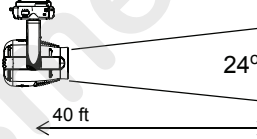
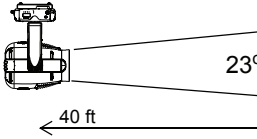
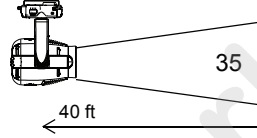
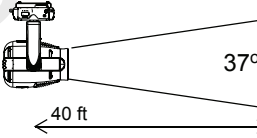
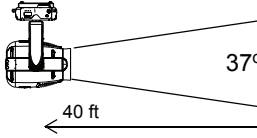
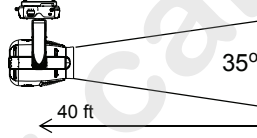
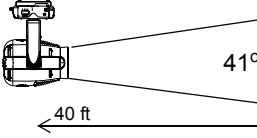
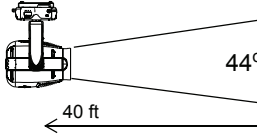

		Front Lens						
		Clear		Stippled		Fresnel		
<b>Internal Lens</b>	<b>Vari-Brite</b>	open	 9.5° 40 ft	59900 lm 4140 fc 44560 lux ø = 6.5 ft TN: .166	 13° 40 ft	54400 lm 2040 fc 21930 lux ø = 9 ft TN: .228	 1° 40 ft	44800 lm 1640 fc 17630 lux ø = 9 ft TN: .228
		<b>Buxom</b>	narrow	 29° 40 ft	41810 lm 325 fc 3500 lux ø = 21 ft TN: .517	 29° 40 ft	39300 lm 288 fc 3100 lux ø = 21 ft TN: .517	 33° 40 ft
	mid		 42° 40 ft	49900 lm 155 fc 1660 lux ø = 31 ft TN: .768	 43° 40 ft	47500 lm 142 fc 1530 lux ø = 2 ft TN: .88	 45° 40 ft	38400 lm 105 fc 1130 lux ø = 33 ft TN: .828
	wide		 52° 40 ft	50000 lm 121 fc 1300 lux ø = 39 ft TN: .975	 53° 40 ft	47900 lm 97 fc 1040 lux ø = 40 ft TN: .997	 54° 40 ft	42700 lm 78 fc 840 lux ø = 41 ft TN: 1.02
	<b>Fresnel</b>		narrow	 22° 40 ft	52200 lm 803 fc 8630 lux ø = 16 ft TN: .388	 24° 40 ft	49900 lm 608 fc 6540 lux ø = 17 ft TN: .425	 23° 40 ft
		mid	 35° 40 ft	41100 lm 310 fc 3301 lux ø = 25 ft TN: .631	 37° 40 ft	40800 lm 245 fc 2640 lux ø = 27 ft TN: .669	 37° 40 ft	40500 lm 216 fc 2320 lux ø = 27 ft TN: .669
		wide	 35° 40 ft	23200 lm 212 fc 2280 lux ø = 25 ft TN: .631	 41° 40 ft	26100 lm 182 fc 1960 lux ø = 30 ft TN: .748	 44° 40 ft	26500 lm 124 fc 1340 lux ø = 32 ft TN: .808

**Notes:**

- All measurements were taken using Osram SharXS® HTI® 1500 W/D7/60 lamps.
- Light output values are nominal and based on the average output of a sample of production luminaires.
- The illuminance (I) values listed in foot candles (fc) and lux are measurements taken at the center of the beam.
- Vari-Brite mode was set to DMX value 255, which opens (splits) the internal lens for maximum light output.
- Internal-lens Zoom settings: narrow (rear position - DMX = 0), mid (mid position - DMX = 127), wide (front position - DMX = 255).
- TN values: For the field angles listed in the table, the coverage diameter (ø) = TN x D (throw distance). For example, a Clear front lens and a Buxom internal lens at the narrow Zoom setting produces a beam with an field angle of ~29°, which provides ø = 21 ft at D = 40 ft. For other distances (D) at this Zoom setting, multiply the TN for 29° x D. For example, at 50 ft, ø = .517 x 50 = 26 ft. Conversely, to get ø = 30 ft with the 29° angle, D = ø/TN = 30/.517 = 58 ft. You can use the TN values for the other field angles in the same way.
- Graphic illustrations in this table are representations only. Do not scale.

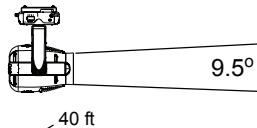
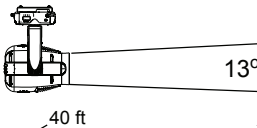
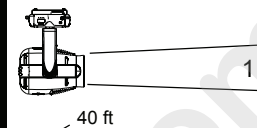

Photometric Data: VL3500 Wash FX Luminaire

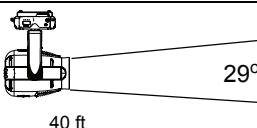
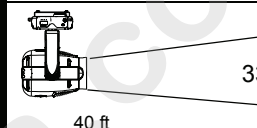
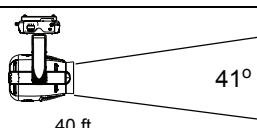
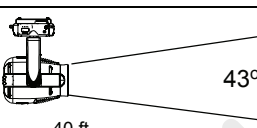
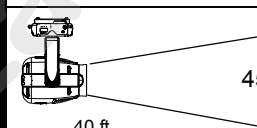
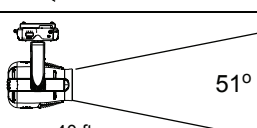
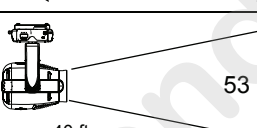
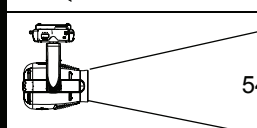
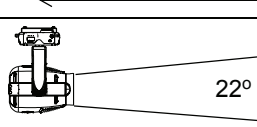
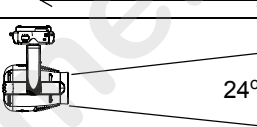
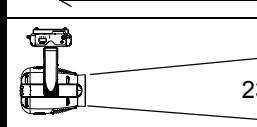
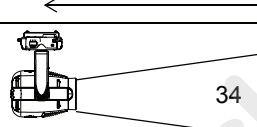
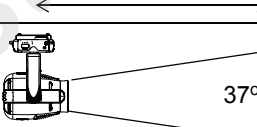
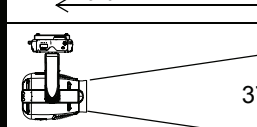
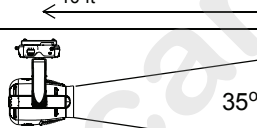
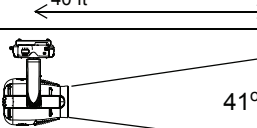
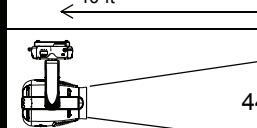
		Front Lens							
		Ultra Clear		Stippled		Fresnel			
<b>Internal Lens</b>	<b>Vari-Brite</b>	open		63300 lm 4980 fc 53600 lux ø = 6.5 ft TN: .166		54400 lm 2040 fc 21930 lux ø = 9 ft TN: .228		44800 lm 1640 fc 17630 lux ø = 9 ft TN: .228	
		<b>Buxom</b>	narrow		42400 lm 377 fc 4060 lux ø = 21 ft TN: .480		39300 lm 288 fc 3100 lux ø = 21 ft TN: .517		30500 lm 171 fc 1840 lux ø = 24 ft TN: .592
			mid		50900 lm 175 fc 18800 lux ø = 31 ft TN: .748		47500 lm 142 fc 1530 lux ø = 2 ft TN: .88		38400 lm 105 fc 1130 lux ø = 33 ft TN: .828
			wide		51200 lm 121 fc 1310 lux ø = 39 ft TN: .954		47900 lm 97 fc 1040 lux ø = 40 ft TN: .997		42700 lm 78 fc 840 lux ø = 41 ft TN: 1.02
	<b>Fresnel</b>	narrow		53900 lm 772 fc 8310 lux ø = 16 ft TN: .389		49900 lm 608 fc 6540 lux ø = 17 ft TN: .425		48000 lm 563 fc 6060 lux ø = 16 ft TN: .407	
		mid		41600 lm 306 fc 3901 lux ø = 25 ft TN: .611		40800 lm 245 fc 2640 lux ø = 27 ft TN: .669		40500 lm 216 fc 2320 lux ø = 27 ft TN: .669	
		wide		25400 lm 214 fc 2300 lux ø = 25 ft TN: .631		26100 lm 182 fc 1960 lux ø = 30 ft TN: .748		26500 lm 124 fc 1340 lux ø = 32 ft TN: .808	

**Notes:**

1. All measurements were taken using Osram SharXS® HTI® 1500 W/D7/60 lamps.
2. Light output values are nominal and based on the average output of a sample of production luminaires.
3. The illuminance (I) values listed in foot candles (fc) and lux are measurements taken at the center of the beam.
4. Vari-Brite mode was set to DMX value 255, which opens (splits) the internal lens for maximum light output.
5. Internal-lens Zoom settings: narrow (rear position - DMX = 0), mid (mid position - DMX = 127), wide (front position - DMX = 255).
6. TN values: For the field angles listed in the table, the coverage diameter (ø) = TN x D (throw distance). For example, a Clear front lens and a Buxom internal lens at the narrow Zoom setting produces a beam with an field angle of ~29°, which provides ø = 21 ft at D = 40 ft. For other distances (D) at this Zoom setting, multiply the TN for 29° x D. For example, at 50 ft, ø = .517 x 50 = 26 ft. Conversely, to get ø = 30 ft with the 29° angle, D = ø/TN = 30/.517 = 58 ft. You can use the TN values for the other field angles in the same way.
7. Graphic illustrations in this table are representations only. Do not scale.

---

**Notes**



VARI\*LITE®  
Express yourself.

Vari-Lite  
10911 Petal Street  
Dallas, Texas 75238 USA  
1-877-VARI-LITE \* 1-214-647-7880  
[www.vari-lite.com](http://www.vari-lite.com)

©2003 - 2009 Vari-Lite, a Philips group company. All Rights Reserved.