

Giotto spot 400

Professional Moving head



User's Manual rel. 1.01



General instructions

Read the instructions in this handbook carefully, as they give important information regarding safety during installation, use and maintenance.

Be sure to keep this instruction manual with the fixture, in order to consult it in the future. If the fixture is sold or given to another operator, make certain he or she also receives the manual, to be able to read about its operation and follow the relative instructions.



- THIS UNIT IS NOT FOR HOME USE, ONLY PROFESSIONAL APPLICATIONS
- AFTER HAVING REMOVED THE PACKAGING, CHECK THAT THE FIXTURE IS NOT DAMAGED IN ANY WAY. IF IN DOUBT, DON'T USE IT AND CONTACT AN AUTHORIZED SGM TECHNICAL SERVICE CENTRE.
- PACKAGING MATERIAL (PLASTIC BAGS, POLYSTYRENE FOAM, NAILS, ETC.) MUST NOT BE LEFT WITHIN CHILDREN'S REACH, AS IT CAN BE DANGEROUS.
- THIS FIXTURE MUST ONLY BE OPERATED BY ADULTS. DO NOT ALLOW CHILDREN TO TAMPER OR PLAY WITH IT.
- ELECTRICAL WORK NECESSARY FOR INSTALLING THE FIXTURE MUST BE CARRIED OUT BY A QUALIFIED ELECTRICIAN OR EXPERIENCED PERSON.



- NEVER USE THE FIXTURE UNDER THE FOLLOWING CONDITIONS:
 - IN PLACES SUBJECT TO EXCESSIVE HUMIDITY
 - IN PLACES SUBJECT TO VIBRATIONS OR BUMPS.
 - IN PLACES WITH A TEMPERATURE OF OVER 45°C OR LESS THAN 2°C
- PROTECT THE FIXTURE FROM EXCESSIVE DRYNESS OR HUMIDITY (IDEAL CONDITIONS ARE BETWEEN 35% AND 80%).
- DO NOT DISMANTLE OR MODIFY THE FIXTURE.

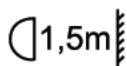

- MAKE CERTAIN THAT NO INFLAMMABLE LIQUIDS, WATER OR METAL OBJECTS ENTER THE FIXTURE.
- THE MINIMUM DISTANCE BETWEEN THE FIXTURE AND THE SURFACE TO BE LIT MUST BE NO LESS THAN 1.5 METRES
- SHOULD ANY LIQUID BE SPILLED ON THE FIXTURE, DISCONNECTED THE POWER SUPPLY TO THE FIXTURE IMMEDIATELY.
- IN THE EVENT OF SERIOUS OPERATING PROBLEMS, STOP USING THE FIXTURE IMMEDIATELY AND EITHER CONTACT THE NEAREST SGM SALES POINT FOR A CHECK OR CONTACT THE MANUFACTURER DIRECTLY.
- DO NOT OPEN THE FIXTURE - THERE ARE NO USER SERVICEABLE PARTS INSIDE.
- NEVER TRY TO REPAIR THE FIXTURE YOURSELF. REPAIRS BY UNQUALIFIED PEOPLE COULD CAUSE DAMAGE OR FAULTY OPERATION. CONTACT YOUR NEAREST AUTHORIZED SERVICE CENTRE.



- WHEN CARRYING OUT ANY WORK, ALWAYS COMPLY SCRUPULOUSLY WITH ALL THE NORMS (PARTICULARLY REGARDING SAFETY) CURRENTLY IN FORCE IN THE COUNTRY IN WHICH THE FIXTURE'S BEING USED.
- Do not place the unit on inflammable parts or material

Always insist on original spare parts being fitted.

General warranty conditions

- THE UNIT IS GUARANTEED FOR 12 MONTHS FROM THE DATE OF PURCHASE AGAINST MANUFACTURING MATERIAL DEFECTS. BREAKDOWN CAUSED BY CARELESSNESS AND IMPROPER USE OF THE FIXTURE IS EXCLUDED.
- THE GUARANTEE IS NO LONGER VALID IF THE UNIT HAS BEEN TAMPERED WITH OR REPAIRED BY UNAUTHORIZED PERSONNEL. REPLACEMENT OF THE FIXTURE IS NOT FORESEEN BY THE GUARANTEE.
- EXTERNAL PARTS, KNOBS, SWITCHES, REMOVABLE PARTS AND LAMPS ARE EXCLUDED FROM THE GUARANTEE: THESE ARE COVERED BY THEIR MANUFACTURERS' GUARANTEE CONDITIONS.
- TRANSPORT COSTS AND RELATED RISKS ARE BORNE BY THE FIXTURE'S OWNER.
THE GUARANTEE IS VALID TO ALL EFFECTS ONLY ON PRESENTATION OF THE GUARANTEE CERTIFICATE TO THE MANUFACTURER OR THE NEAREST SGM TECHNICAL ASSISTANCE CENTRE.
- ALWAYS QUOTE THE UNIT'S SERIAL NUMBER AND MODEL WHEN CONTACTING YOUR RESELLER FOR INFORMATION OR ASSISTANCE.

Protect the environment: don't throw packing material into your garbage can return it to your SGM retailer or take it to the nearest special waste collection point.

index

GENERAL WARNINGS AND INSTRUCTIONS	1
GUARANTEE CONDITIONS	1
PRESENTATION	3
MAIN FEATURES	4
ACCESSORIES	5
SYMBOLS USED	5
ELECTRICAL SPECIFICATIONS	6
MECHANICAL FEATURES	6
1 INSTALLATION	7
1.2 ACCESS TO INTERNAL COMPONENTS	8
1.3 INSTALLING THE LAMP	9
1.4 LAMP ALIGNMENT	9
1.5 INSTALLING /REPLACING GOBOS	10
1.6 FITTING/REMOVAL GOBO ADAPTER	10
1.7 INSTALLING /REPLACING COLOR FILTERS	12
1.8 CONSTRUCTING A POWER CORD	12
1.9 GIOTTO SPOT'S POWER SUPPLY	12
1.91 MOUNTING THE FIXTURE ON TRUSSING OR SIMILAR STRUCTURES	12
1.92 POSITIONING THE FIXTURE	13
1.93 INSTALLING THE CLAMPS	13
2 SIGNAL CABLE	14
2.1 DMX TERMINATION PLUG CONSTRUCTION	14
2.2 RS-232 CONNECTION	15
3 "CONTROL" MICROCOMPUTER	16
3.1 MENU NAVIGATION	16
3.2 ALLOCATING THE START CHANNEL (ADDRESSING)	18
3.3 PAN DIRECTION	18
3.31 LIMITING PAN	18
3.4 TILT DIRECTION	19
3.41 LIMITING TILT	19
3.5 INVERTING PAN/TILT	19
3.6 LAMP ELAPSED TIME COUNTER	19
3.61 RESETTING THE LAMP ELAPSED TIME COUNTER	19
3.7 LAMP STRIKE (IGNITION) COUNTER	20
3.71 RESETTING THE LAMP STRIKE COUNTER	20
3.8 FIXTURE OPERATING TIME COUNTER	20
3.9 INPUT SIGNAL	20
3.10 PAN/TILT MOVEMENT RESOLUTION	20
3.11 REMOTE CONTROLLED LAMP STRIKE (IGNITION)	20
3.12 REMOTE CONTROLLED FIXTURE RESET	21
3.13 CONTROLLING ACCELERATION AND SPEED	21
3.14 DISPLAY BRIGHTNESS	21
3.15 DISPLAY VIEWING POSITION	21
3.16 DMXDLY	21
3.17 LOCKING/UNLOCKING THE SHUTTER	22
3.18 SETTING DEFAULT PARAMETERS	22
3.19 RESTORING DEFAULT PARAMETERS	22
3.20 SETTING THE STARTING POSITION OF THE ROTATING GOBOS AND THE GOBO, COLORS, EFFECTS WHEELS	22
3.21 TEST FUNCTIONS	23
3.22 RESERVED FUNCTIONS	23
4 GIOTTO SPOT 400'S CONTROL CHANNELS	23
4.1 IRIS CHANNEL -CH 5-	23
4.2 COLOR CHANNEL -CH 6-	24
4.3 GOBO CHANNEL -CH 7-	25
4.4 SHUTTER/STROBE CHANNEL - CH 8-	26
4.5 DIMMER -CH 9-	26
4.6 GOBO ROTATION -CH 10-	26
4.7 PRISMS -CH 11-	26
4.8 PRISM ROTATION - CH 12-	26
4.9 ELECTRONIC FOCUS -CH 13-	27
4.10 ZOOM- CH 14 -	27
4.11 EFFECTS WHEEL -CH 15-	27
4.12 FROST - CH 16 -	28
4.13 MSPEED - CH 17 -	28
4.14 REMOTE LAMP STRIKING AND RESET -CH 18-	28
4.15 GOBOSHAKE - CH 19 -	28
4.16 COLOR MODE -CH 20-	29
4.17 GOBO MODE -CH 21-	29
4.18 MACROS -CH 22-	29
CONVERSION TABLES	29

Presentation

Giotto Spot is SGM's innovative professional moving head spot, specifically manufactured for use in high profile shows, theatres, Television studios and entertainment venues in general.

Thanks to its cutting edge performance, the result of SGM's lengthy experience in mechanical and electronic design, Giotto Spot is one of the world's best.

Its use of an MSR 400HR discharge lamp and a perfect optical system makes it one of the best fixtures currently on the market.



*Made in Italy by SGM Electronic
Printed in September 2001 Rel.1.01*

Main features

Lamp

Giotto Spots use a Philips MSD 400HR (6000°K) discharge lamp.

Effects

- Linear zoom (9° - 24°)
- Fast linear iris
- Automatic electronic focus
- Linear dimmer (0-100%)
- Shutter / strobe 12 fps with music sync
- Colour wheel with 8 positions + white, supplied as standard with 8 dichroic colours
- Effects wheel with 8 positions + white, fitted with 2 conv. filters, UV filter, 2 fixed gobos, 2 glass (texture) gobos, amber filter.
- Colours can be fitted on the effects wheel, obtaining a total of 16 distinct colours.
- Gobos can be fitted on the effects wheel and colour wheel using adapters.
- Variable speed gobo scrolling
- Gobo shake
- Rainbow effect on gobo wheel.
- Color change and gobo change with blackout
- Color change and gobo change with music sync
- 2-tone beam, analog color selection, 16-speed rainbow
- 14-facet rotating prism with adjustable speed in both directions
- 5-facet rotating ½ prism (COMETA) with adjustable speed in both directions
- Linear variable frost filter: from soft-edge to full-wash
- Wood filter, CTO filter
- Automatic re-positioning with black-out
- Macros

Movement

- 540° Pan (2.8sec.) and 270° Tilt (1.7sec.)
- 8/16 bit movement resolution
- Automatic re-positioning in the event of accidental head movement
- Possibility of inverting Pan and Tilt movement
- Possibility of limiting Pan and Tilt range
- Variable acceleration and speed parameters

Electronic Ballast

Supplied as standard with every fixture

- Automatic universal power supply acceptance: 90-245V 50,60Hz
- Flicker-free
- Lamp power reduction in the event of fixture overheating
- Power Factor Correction
- Automatic energy saving in the event of beam black-out
- Hot re-strike.

Optics

- High luminous efficiency Optics
- Linear beam projection angle variation (9° - 24°)
- Autofocus

Display/Microcomputer

- The fixture can be "customized" according to type of installation: function tests available for each effect; Lamp On/Off via DMX can be enabled; Fixture reset via DMX can be enabled; fixture addressing; display "flip" function (rotates through 180°); adjustable display brightness and more.
- Info displayed includes: lamp elapsed time and strike counters, fixture operating time counter, software version supported.

Control signal

Input signal DMX 512 - RS 232

Mounting System

- "Fast-Lock" clamps supplied as standard with fixture
- Several clamp mounting points to enable the fixture to be mounted on any type of truss
- Safety chain/cable mounting points

Accessories

- Single flight case
- Double flight case

cod:0061745
cod:0061746



Symbols used



THIS SYMBOL INDICATES A GENERAL RISK



THIS SYMBOL INDICATES ELECTRIC SHOCK RISK



THIS SYMBOL INDICATES A HOT SURFACE



THIS SYMBOL MEANS "DO NOT PLACE THE UNIT ON INFLAMMABLE PARTS OR MATERIAL"

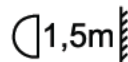

THIS SYMBOL INDICATES THAT THE MINIMUM DISTANCE BETWEEN THE FIXTURE AND THE SURFACE TO BE LIT MUST BE NO LESS THAN 1.5 METRES

ELECTRICAL SPECIFICATIONS



DANGER!! CLASS 1 FIXTURE. THIS UNIT MUST BE GROUNDED

POWER REQUIREMENTS: UNIVERSAL 90V-245 V 50Hz,60Hz.

POWER ABSORBED: 520W

FUSED 2Pz - 8A CT

LAMP SPECIFICATIONS

LAMP:	MSR 400HR
LUMINOUS EFFICACY	80 LM/W
COLOR COORDINATES	X, Y 328,323
COLOR TEMPERATURE	6000°K
LUMINOUS FLUX:	32000 LUMENS
AVERAGE LIFE (50%)	750 HR.
CAP/BASE	Gzz9,5

OPTICAL SYSTEM:

INTERNAL OPTICAL GROUP COMPRISING HIGH LUMINOUS EFFICIENCY DICHROIC REFLECTOR; LINEAR BEAM ANGLE ADJUSTMENT (9° - 24°) ELECTRONIC FOCUS.

METAL GOBO

DIAMETER:	30MM
IMAGE AREA:	24MM

DICHROIC GOBO

DIAMETER:	28MM
IMAGE AREA:	24MM
THICKNESS	1,1MM

COLOR FILTER

DIAMETER:	34MM
THICKNESS:	1,1MM

SETTING: VIA BUILT-IN MICRO-COMPUTER

CONTROL SIGNAL: USITT DMX 512 OR RS-232 DM CONTROL

CHANNELS REQUIRED: 22

Mechanical Features

BODY: STRUCTURE IN CAST ALUMINIUM COATING IN MOULDED TERMOPLAST

WEIGHT: 24.8 KG.

DIMENSIONS (MM.)

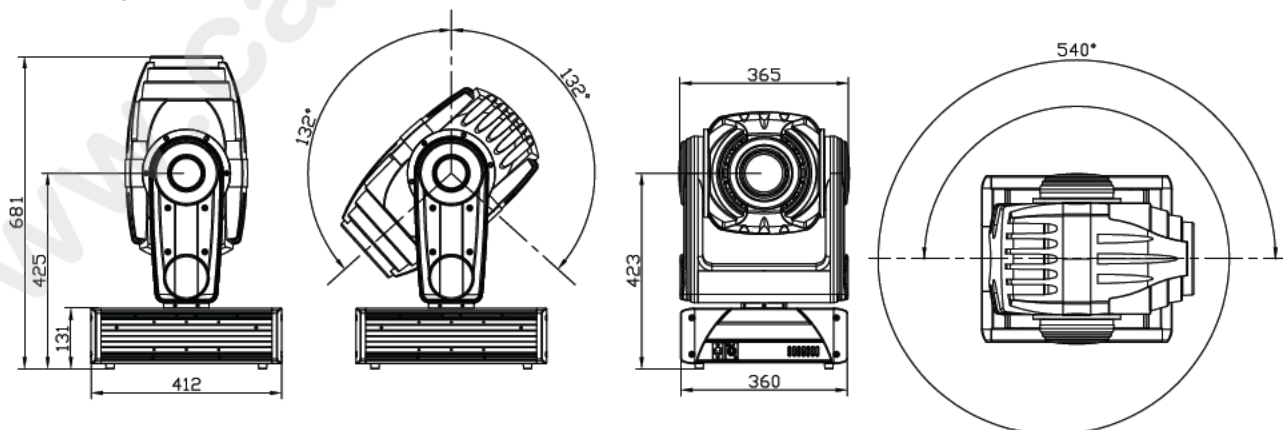

**SGM Elettronica reserves the right to improve or modify its products at any time.
Always refer to the manual supplied with the unit to
avoid any risk of mistakes or operation which
does not correspond to manual indications.**

Changes to this manual

SGM has an on-going product development policy, so the information printed in this manual may not be completely up to date. If any doubts arise regarding the topics covered in this manual or should any further help be required, our online services (internet-server www.sgm.it) are available 24 hours a day. In the FAQ section of the technical assistance zona, answers can be found to numerous common queries: fixtures, firmware and manuals can also be downloaded whenever required.



Items supplied

Before proceeding with fixture installation, make certain that the packing contains all the items shown in the following list and ensure that the fixture is undamaged.

If in doubt, don't use the fixture and contact an authorized SGM technical assistance centre and the freight company. In fact, only the recipient can claim for any damage caused to the fixture during transport.

- GIOTTO SPOT 400
- WARRANTY
- INSTRUCTION MANUAL
- 1 MALE XLR 5 P CONNECTOR
- 1 FEMALE XLR 5 P CONNECTOR
- 1 POWER-CON CONNECTOR
- 2 FAST-LOCK CLAMPS

KEEP THE PACKING MATERIAL.

PACKING MATERIAL (PLASTIC BAGS, POLYSTYRENE FOAM, NAILS, ETC.) IS POTENTIALLY HAZARDOUS, SO MUST NEVER BE LEFT WITHIN CHILDREN'S REACH. USE THE ORIGINAL PACKING IN THE EVENT OF HAVING TO RETURN THE FIXTURE TO THE MANUFACTURER FOR REPAIR OR MAINTENANCE: IT'S BEEN DESIGNED SPECIFICALLY TO PROTECT THE FIXTURE DURING TRANSPORT.

1.2 Access to internal components

Giotto fixtures have a simple head opening mechanism.

All work must ALWAYS be carried out by qualified technical personnel.



ATTENTION: make certain that the fixture is switched off and that there is no risk of burns due to high component temperature (wait at least 30 minutes after switching off)

To access internal components, proceed as follows:

1. Loosen the two screws shown in Fig.1 on both sides of the fixture
2. Remove the cover (1) in the direction indicated by the arrow (Fig. 2)

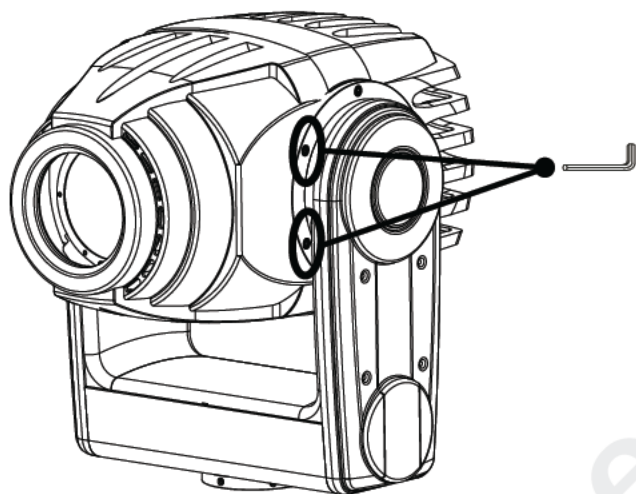

Fig. 1

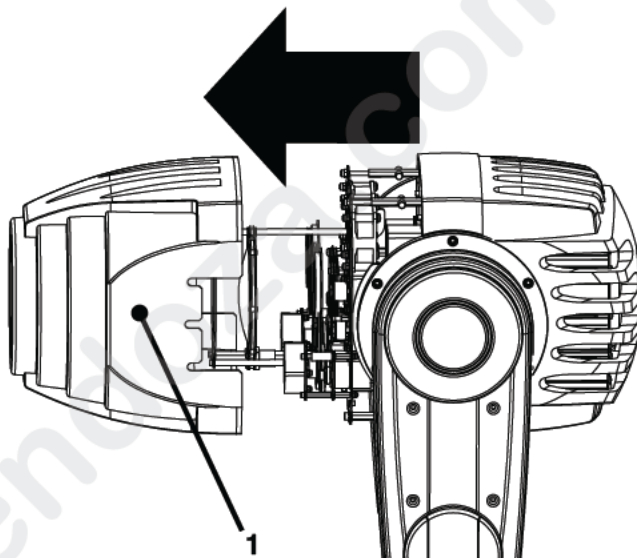

Fig. 2

3. Unscrew the two threaded pins (5)(6) as shown in Fig.3
4. Swivel the whole block downwards (Fig. 4)

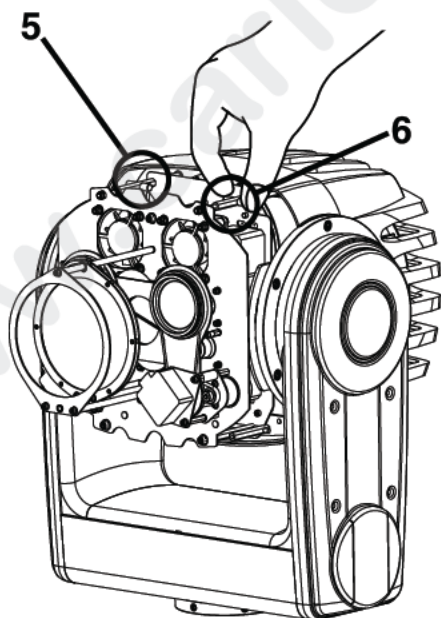

Fig. 3

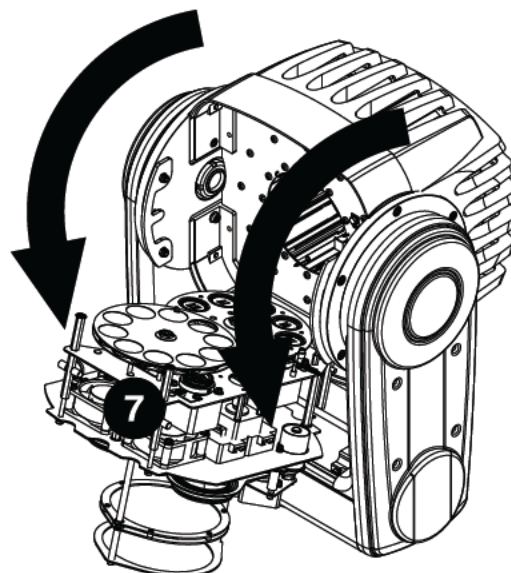

Fig. 4

1.3 Installing the lamp



ATTENTION! This fixture is designed exclusively for use with Philips MSD 400HR lamps. NEVER USE ANY OTHER TYPES OF LAMPS.



- DISCONNECT THE POWER SUPPLY BEFORE CARRYING OUT ANY WORK ON THE FIXTURE.
- MAKE CERTAIN THAT THE FIXTURE IS OFF AND THE TEMPERATURE OF THE COMPONENTS CAN'T CAUSE BURNS (WAIT AT LEAST 30 MINUTES AFTER SWITCHING OFF).



- NEVER CARRY OUT ANY WORK IF THE FIXTURE DOESN'T HAVE ITS PROTECTIVE COVERS OR ITS LENSE ARE DAMAGED. DISCHARGE LAMPS CAN EXPLODE.

- NEVER LOOK DIRECTLY AT THE LAMP WHEN IT'S LIT - DISCHARGE LAMPS EMIT UV RAYS WHICH ARE DANGEROUS FOR SIGHT.

Inside the fixture's moving head, there is an optical system. Follow the following instructions when installing a lamp or relamping.

1. Disconnect the power supply, put on protective gloves and eyewear.
2. Open the fixture (see paragraph 1.2) and fit the lamp as shown in figures 4, 5, 6 and 7

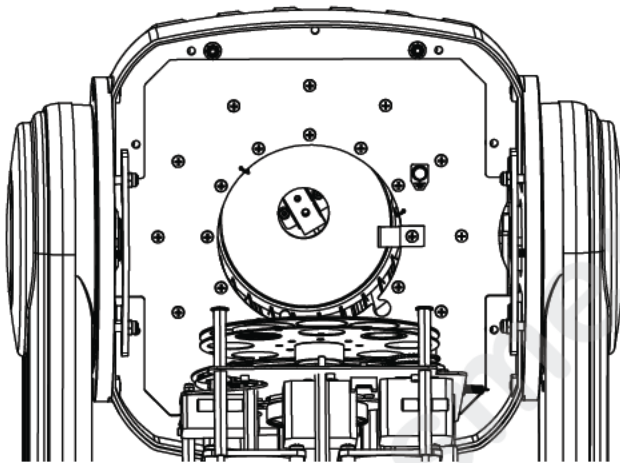

Fig 4



Fig. 5



ATTENTION!! When fitting a lamp, always use gloves or soft lint-free cloth - never touch it with your bare hands.

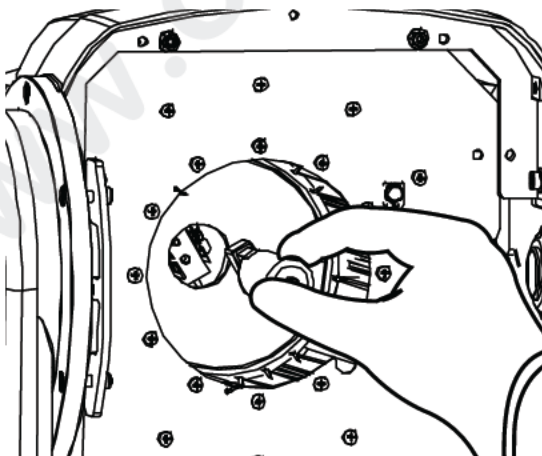

Fig. 6

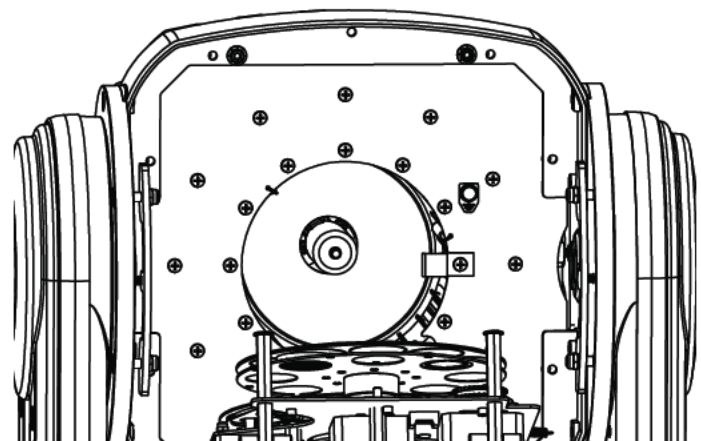
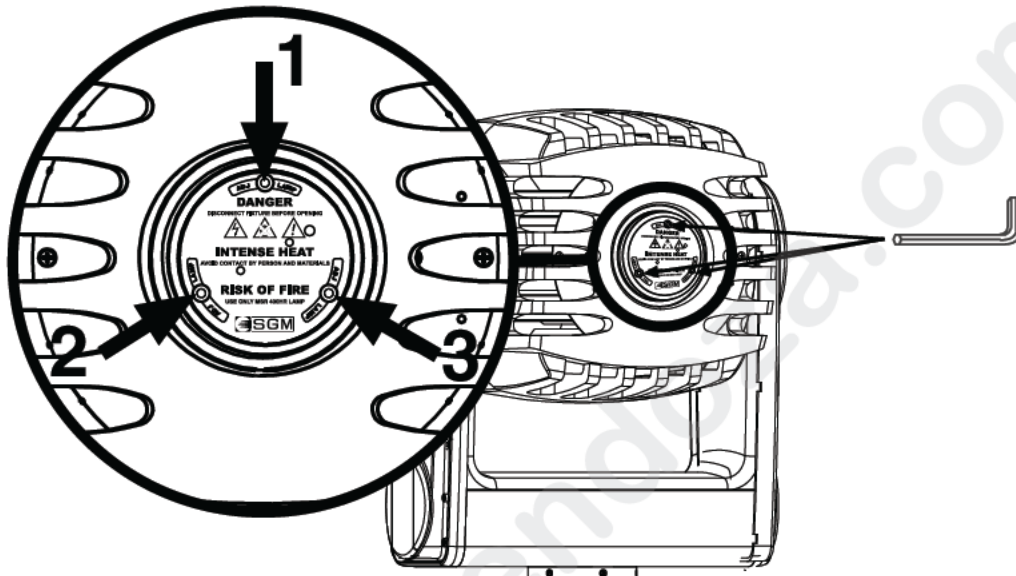

Fig. 7

1.4 Lamp alignment

Every time a new lamp is installed in the fixture, it must be aligned with the optical system to ensure optimum even light output from the unit.

1. Install the new lamp (par. 1.3), close the fixture and switch it on
2. Connect the fixture to a lighting console.
3. Point the fixture at a flat surface (if possible white or light colored) at least three metres from the fixture.
4. Set the control channels to obtain a white beam. Then open the IRIS, set the DIMMER fully open, FOCUS correctly and do NOT project GOBOS or COLORS.
6. Use screws 1, 2 and-3 to align the lamp until an evenly projected light beam is obtained, with no shadows or zones which are brighter than others.



1.5 Installing /replacing gobos

Metal: After opening the fixture, locate the gobo to be replaced, press delicately downwards (Fig.1) until the spring and the gobo come out, making sure they don't fall inside the fixture. Install the new gobo (1) as shown (Fig.2), followed by the locking spring (2).

Dichro: After opening the fixture, locate the gobo to be replaced, press delicately downwards (Fig.1) until the spring, ring and the gobo come out, making sure they don't fall inside the fixture. Install the new gobo (3) as shown (Fig.2), followed by the ring (4) and the locking spring (5).

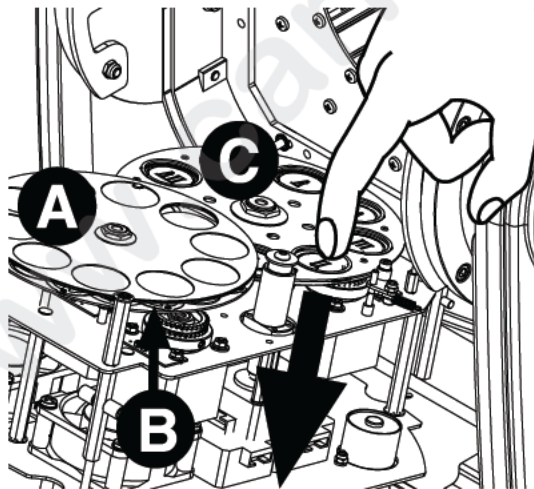

Fig.1

A: Color wheel
B: Effects wheel
C: Gobo wheel

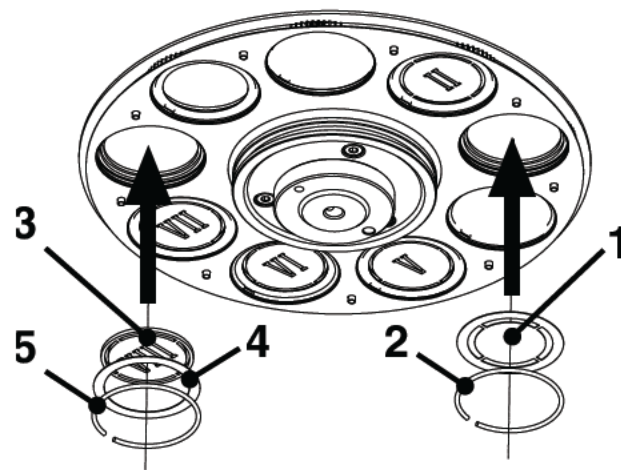

Fig 2

1.6 Fitting/removal gobo adapter

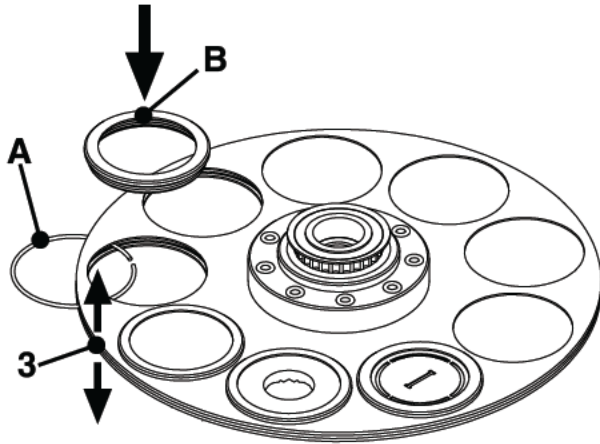

fig. 3

FITTING: Select the position in which the adapter is to be installed on the effects wheel, remove the colour filter if there is one (par. 1.7), open the disks (3) using the least possible force, slide the spring (A) in until it fits into the engraved slot, then fit the adapter (B) by pushing lightly in the direction indicated by the arrow.

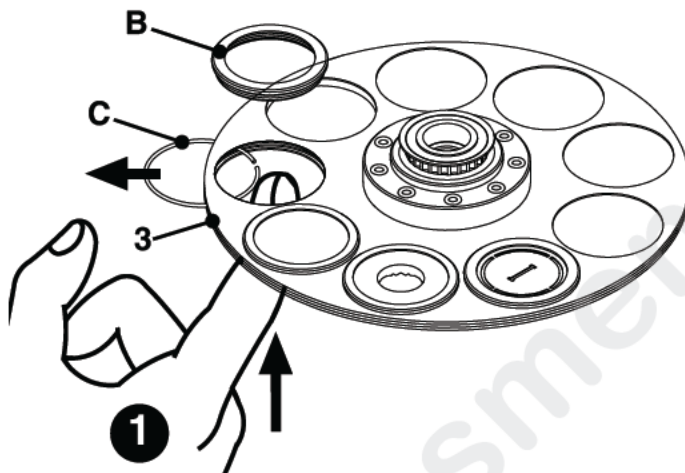
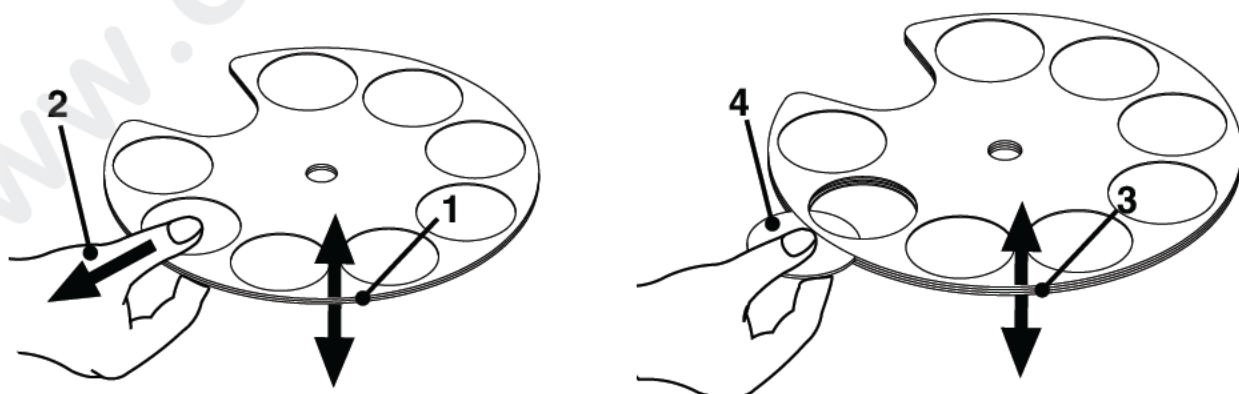

fig. 4

REMOVAL: Select the adapter to be removed from the effects wheel, push lightly upwards (see figure 4 point 1) until it comes out of its position and remove the adapter (B). Open the disks (3) and remove the spring (C).

1.7 Installing /replacing color filters

Choose which of the wheel's dichroic filters is to be replaced, grip it firmly between your fingers, carefully widen the discs (1), slide the filter out in the direction indicated by the arrow (2). Carefully widen the discs again (3) and slide the new filter in (4) until it fits into its engraved slot.



1.8 Power cable construction



DANGER! ELECTRICAL SHOCK HAZARD

- ELECTRICAL WORK NECESSARY FOR INSTALLING THE FIXTURE MUST BE CARRIED OUT BY A QUALIFIED PERSON.
- CLASS 1 DEVICE, THE FIXTURE MUST BE SUITABLY EARTHED.

The POWER-CON type connector supplied along with the Giotto is indispensable for connecting the fixture to the power supply. The following design shows how to connect the connector to the cable, whereas the table shows the symbols normally used to indicate connections. When in doubt, consult a qualified electrician.

CABLES	PIN	TYPICAL	US	UK
Brown	Phase	"L"	Yellow/Copper	Red
Blue	Neutral	"N"	Silver	Black
Yellow/Green	Ground		Green	Green

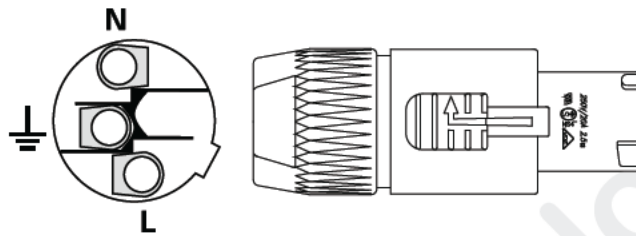

1.9 - Giotto Spot's power supply



ATTENTION!!

- DON'T POWER THE GIOTTO WITH A DIMMER CIRCUIT - THIS COULD DAMAGE THE ELECTRONIC BALLAST.
- BEFORE CONNECTING THE FIXTURE, MAKE CERTAIN THAT THE DATA ON THE FIXTURE'S PLATE CORRESPOND WITH THOSE OF THE LOCAL MAIN POWER SUPPLY.
- THE FIXTURE MUST BE CONNECTED TO A CUT-OFF CIRCUIT.

1.91- Installing the fixture on a support structure

READ THE FOLLOWING SAFETY INFORMATION BEFORE PROCEEDING WITH THE INSTALLATION OF THE FIXTURE:



- FIXTURE NOT FOR DOMESTIC USE.
- DO NOT INSTALL THE FIXTURE NEAR SOURCES OF HEAT.
- INSTALL THE FIXTURE IN A WELL VENTILATED PLACE.
- AVOID BLOCKING AIR INTAKES AND OUTPUTS.



- DO NOT USE THE FIXTURE:
- IN PLACES SUBJECT TO VIBRATIONS OR BUMPS
 - IN PLACES WITH EXCESSIVE HUMIDITY
 - IN PLACES SUBJECT TO TEMPERATURES OF MORE THAN 45° OR LESS THAN 2°C

- DO NOT PLACE THE UNIT ON INFLAMMABLE PARTS OR MATERIAL
- PROTECT THE FIXTURE FROM EXCESSIVE HUMIDITY (IDEAL VALUES ARE BETWEEN 35 AND 80%).
- AVOID INFLAMMABLE LIQUIDS, WATER OR METALLIC OBJECTS ENTERING THE FIXTURE.
- DON'T LIFT THE FIXTURE HOLDING IT BY THE MOVING PART (THE HEAD).
- POSITION THE FIXTURE AT LEAST 1.5M. FROM THE SURFACE TO BE LIT.
- KEEP ANY INFLAMMABLE MATERIAL AT A DISTANCE OF AT LEAST 1.5M FROM THE FIXTURE.



1.92 Positioning the fixture

Can be installed in any position.



1.93 Fitting clamps

- Always use two clamps to hang the fixture.
- Fix the fixture to the support structure using safety chains fitted to the 2 holes on the underside of the fixture's base (Fig.2).
- Don't fix the safety chain to the handles.

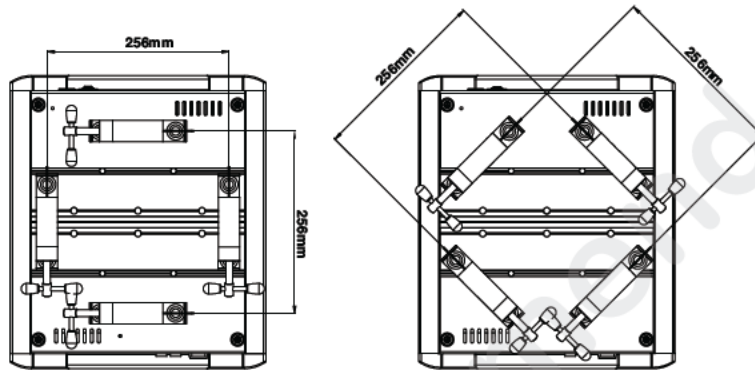

CLAMPS CAN BE USED AS FOLLOWS

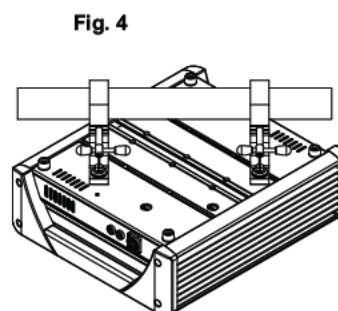
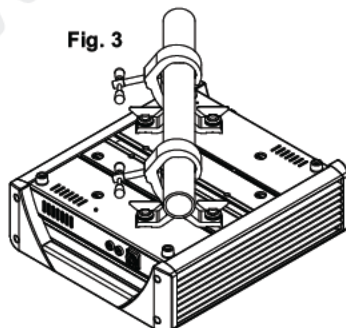
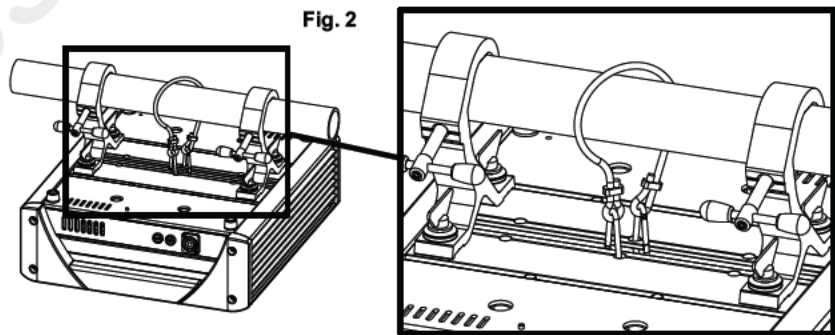
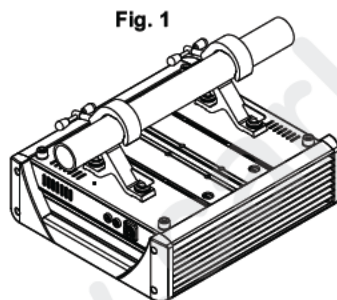

2.0 -Construction of the signal cable

Giotto spot has a DMX 512 input fitted with standard 5-pin XLR connectors. Screened cables in compliance with EIA RS-485 specifications and the following characteristics must be used for connections:

- 2 conductors plus screen
- 120Ohm impedance
- low capacitance
- max. transmission rate 250kBaud.

Cable connections:

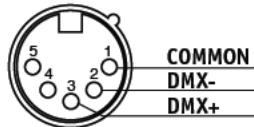

see illustration, taking care with the screen, which must be connected to P 1



ATTENTION: the screened parts of the cable (sleeve) must NEVER be connected to the system's earth, as this would cause faulty fixture and controller operation.

Example of connection of the DMX line

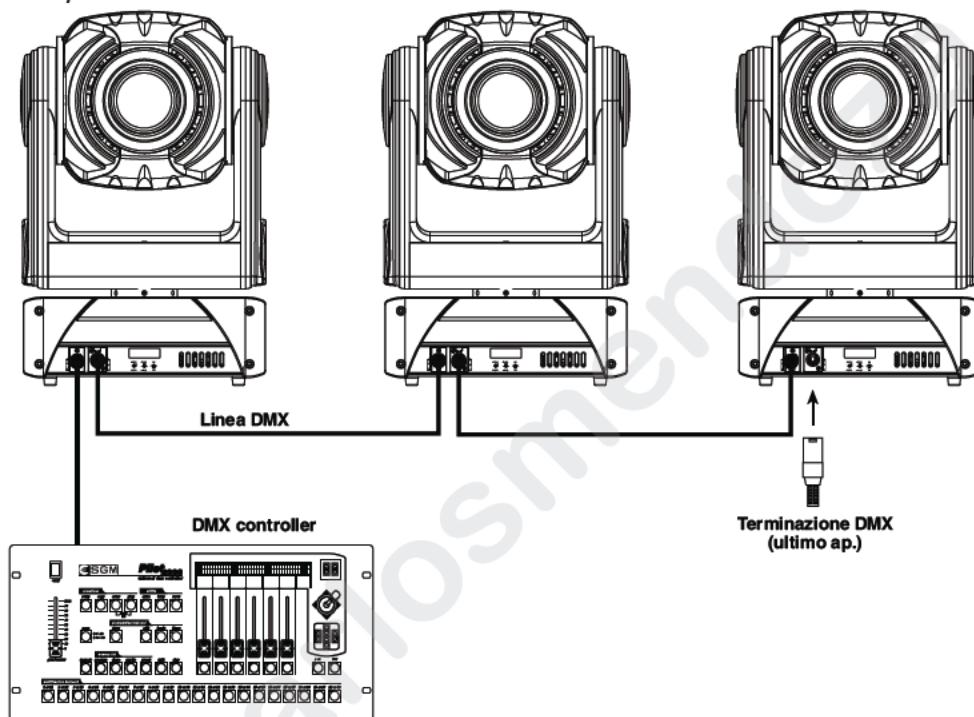

To avoid the risk of faulty operation, follow these indications:

Maximum cable length: 500 metres

Max. N° of fixtures connected: 32

Cable runs: Avoid running cables alongside power supply lines.

Termination: A 120Ohm resistor between Pins 2 and 3 on the last fixture.

2.1 Construction of the DMX termination

The termination avoids the risk of DMX 512 signals being reflected back along the cable when they reach the end of the line: under certain conditions and with certain cable lengths, this could cause them to cancel the original signals.

The termination is prepared by soldering a 120Ohm 1/4 W resistor between pins 2 and 3 of the 5-pin male XLR connector (see diagram).

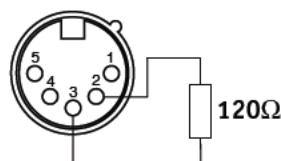

2.2 RS232 connection

For this connection, use good quality screened coax cable (RG58 50Ohms) to avoid problems with signal transmission and faulty fixture operation.

Connectors must always be 5-pin XLRs. Refer to the diagram for wiring.

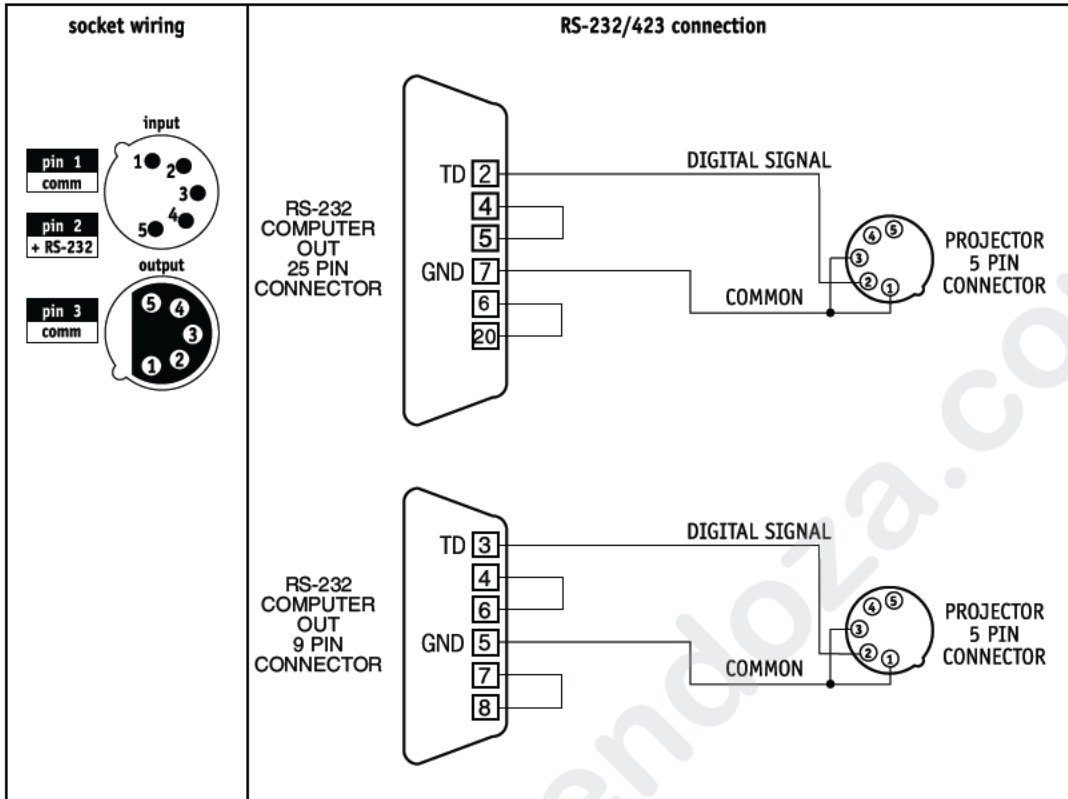

3.0 "Control" Microcomputer

Giotto Spot is equipped with a microcomputer which allows to customize the fixture to suite the type of installation. In fact, it's possible to assign the start address; obtain information regarding lamp life and fixture operation time; run test programs to check correct fixture operation and customize some parameters.

3.1 Navigating in the menu

When it's switched on, the fixture runs a start-up reset procedure and the display indicates if there's an input signal or not.

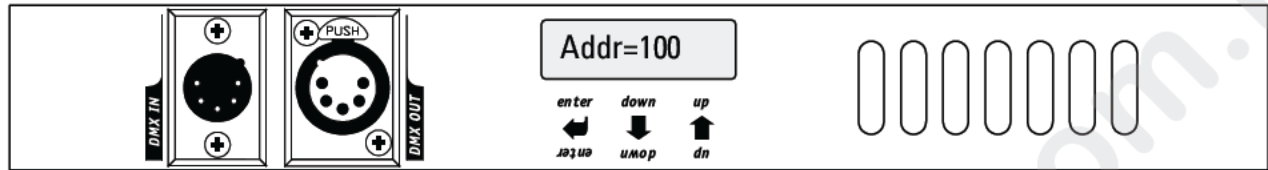

The 3 keys under the display are for selecting and using the various submenus which make up the main menu.

- **UP/DOWN** keys: used to scroll the various items in the menu. In the selected menu, used to change the required parameters.
- **ENTER** key: used to access to the selected menu and, once the necessary changes have been made, is used to confirm them.

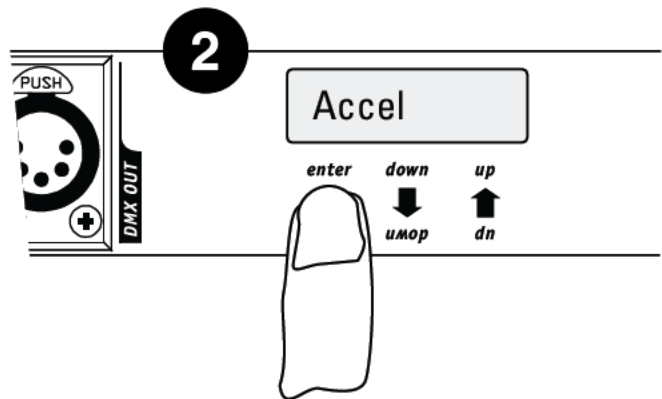
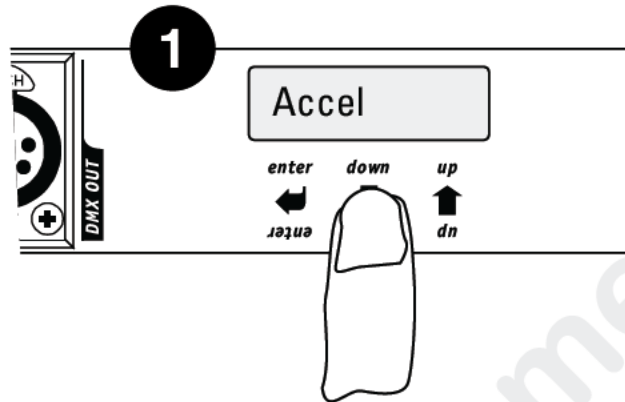



Menu	Options	Description
Addr=xxx	Range 001 495	Fixture addressing
Pmove	NORM	Normal PAN control of left to right PAN movement.
	REV	Inverted PAN movement control (from right to left).
PP_min	Range 000 540	Sets PAN movement start position. Default configuration = 000 degrees
PP_max	Range 000 540	Sets PAN movement stop position. Default configuration = 000 degrees
Tmove	NORM	Normal control of TILT from up to down.
	REV	Inverted TILT movement control (from down to up).
TP_min	Range 000 270	Sets TILT movement start position. Default configuration = 000 degrees
TP_max	Range 000 270	Sets TILT movement stop position. Default configuration = 000 degrees
SWAP	ON	Data regarding Pan controls Tilt and vice versa.
	OFF	Normal control of Pan and Tilt movement.
LMP_H		Read-only Menu. Stores lamp elapsed time. Can be reset.
LMP_st		Read-only Menu. Stores the number of lamp strike. Can be reset.
SCN_h		Read-only Menu. Stores fixture operating time.
SIGN	DMX	DMX signal selected
	RS 232	RS-232 signal selected
SMD	16 bit 8 bit	Enables selection of movement resolution Default configuration = 16 bit
LMP_ctr	EN	Remote lamp ignition enabled.
	DS	Remote lamp ignition disabled
RST_ctr	EN	Remote reset enabled.
	DS	Remote reset disabled
Speed	100% 92% 84% 76%	Allows to slow maximum Pan and Tilt speed. Default configuration = 00%
Accel	Fast	Optimises speed performance.
	Slow	Optimises smooth movement
Bright	100 50 40 27 20 13 6 0 (%)	Allows adjustment of display brightness. Default configuration = 40%
DsPlFlip		Reverts display reading position. Used according to the position in which the fixture is installed.
DMXdly	Range 0 600sec	It's possible to set the number of second for which the fixture's last operating status must be held when there is no DMX signal. (default = 20sec.)
	UNL	Always maintains the fixture's last operating status no matter for how long there is no DMX signal.
CSHUTT	CSHUTT=DS	Disables shutter closure in the event of loss of position
	CSHUTT=EN	Enables shutter closure in the event of loss of position
FACT	FACT=SE	Enables to set default parameters
	FACT=OFF	FACT Value during normal operation
PREV	PREV=SET	Enables to restore the values of the parameters set immediately before FACT=SET procedure
	PREV=OFF	PREV value during normal operation
SETTING	COL=1200	Enables to set the offset for calibrating the starting position of the colour wheel
	G0B=2000	Enables to set the offset for calibrating the starting position of the gobo wheel
	RG0B=1100	Enables to set the offset for calibrating the starting position of the rotating gobos
	EFF=2000	Enables to set the offset for calibrating the starting position of the effects wheel
TEST		-
	TEST=RESET	Fixture RESET.
Reserved		-
ADDR=100		Under normal operating conditions, the display shows this message (100 is the DMX 512 channel on which the first channel set)

3.2 Allocating the first addressed channel

Addr=xxx

In order to receive the commands necessary to operate from a lighting console, each fixture has to be allocated a start address. This address normally indicates the first channel used (start channel) and can be allocated following a different criterion from that used to connect the signal line. Giotto Spot uses 22 controls channels, so during allocation, this quantity must be borne in mind to avoid possible overlapping of other fixtures' channels, which would cause problems with the perfect control of all the available functions. Should it be necessary, it's possible to allocate the same start channel to several fixtures, in this case the fixtures will all follow the same commands, but can't be controlled separately. To address fixtures correctly, proceed as follows:

1. Connect Giotto Spot to the power supply, wait until it has completed reset operations and "DMX signal" appears on the display.
2. Use the UP/DOWN keys to find the "Addr" menu
3. Press ENTER to confirm. The message on the display starts to flash.
4. Use the UP/DOWN keys to select the channel required.
5. Press ENTER to confirm.

Fixture N°.	Start Channel	Fixture N.	Start Channel	Fixture N°.	Start Channel	Fixture N .	Start Address
1	001	8	185	15	346	22	507
2	024	9	208	16	369		
3	047	10	231	17	392		
4	070	11	254	18	415		
5	093	12	277	19	438		
6	139	13	300	20	461		
7	162	14	323	21	484		

3.3 Direction of Pan movement

Pmove=NORM

This function allows to decide the direction in which the fixture's moving head pans, indispensable when several fixtures are installed in order that fixtures installed opposite each other move in the same direction when they receive a command.

To modify Pan movement, proceed as follows:

1. Connect the Giotto Spot to the power supply, wait till it has completed reset operations and "DMX signal" appears on the display.
2. Use the UP/DOWN keys to find the "Pmove" menu
3. Press ENTER to confirm. The message on the display will start to flash.
4. Use the UP/DOWN keys to select which of the two available options is required (see table pag.15).
5. Press ENTER to confirm.

3.31 Setting Pan starting angle

PPmin=000

The Giotto fixture has a Pan movement range of 540° (a revolution and a half). If the entire excursion doesn't have to be used, two parameters allow to set the starting angle (PP_min) and ending angle (PP_max). The only limit is the minimum difference between starting (MIN) and ending angle (MAX), which is 4°.

To limit Pan movement, proceed as follows:

PPmax=000

1. Connect Giotto Spot to the power supply, wait till it has completed reset operations and "DMX signal" appears on the display.
2. Use the UP/DOWN keys to find the "PP_min" menu if the starting angle has to be modified. If the ending angle has to be modified, find the "PP_max" menu.
3. Press ENTER to confirm. The message on the display will start to flash.
4. Use the UP/DOWN keys to select the new starting (or ending) angle.
5. Press ENTER to confirm.

3.4 Direction of Tilt movement

Tmove=NORM

This function allows to decide the direction in which the Giotto's moving head tilts, indispensable when several fixtures are installed in order that fixtures installed opposite each other move in the same direction when they receive a command. To modify Tilt movement, proceed as follows

1. Connect Giotto Spot to the power supply, wait till it has completed reset operations and "DMX signal" appears on the display.
2. Use the UP/DOWN keys to find the "Tmove" menu
3. Press ENTER to confirm. The message on the display will start to flash.
4. Use the UP/DOWN keys to select which of the two available options is required (see table pag.15) 5. Press ENTER to confirm.



3.4.1 Limiting Tilt movement

TPmin=000

The Giotto fixture has a Tilt movement range of 270° (3/4 of a revolution). If the entire excursion doesn't have to be used, two parameters allow to limit the starting angle (TP_min) and ending angle (TP_max). The only limit is the minimum difference between starting (MIN) and ending (MAX), which is 4°.

To limit the Tilt movement, proceed as follows:

TPmax=000

1. Connect Giotto Spot to the power supply, wait till it has completed reset operations and "DMX signal" appears on the display.
2. Use the UP/DOWN keys to find the "TP_min" menu if the starting angle is to be modified. If the ending angle is to be changed, find the "TP_max" menu.
3. Press ENTER to confirm. The message on the display will start to flash.
4. Use the UP/DOWN keys to select the new starting (or ending) angle.
5. Press ENTER to confirm.

3.5 Pan/Tilt inversion

Swap=OFF

This function also allows to optimize the movement of the Giotto's moving head in relation to the operator's position, in order to simplify all positioning procedure. When SWAP is enabled (ON), this means that the Giotto console sends the data regarding Pan to the Tilt controls and vice versa.

To invert PAN and TILT movement, proceed as follows:

1. Connect Giotto Spot to the power supply, wait till it has completed reset operations and "DMX signal" appears on the display.
2. Use the UP/DOWN keys to find the "SWAP" menu.
3. Press ENTER to confirm. The message on the display will start to flash.
4. Use the UP/DOWN keys to select which of the two available options is required (see table pag.15)
5. Press ENTER to confirm.

3.6 Lamp elapsed time meter

Lmp_H

The Giotto microcomputer stores various data, including that relative to the number of hours the lamp is lit (elapsed time). This is necessary to know in advance when it's almost time for relamping: lamp life is approximately 750 hours.

To see how many hours a lamp has been used, proceed as follows:

1. Connect Giotto Spot to the power supply, wait till it has completed reset operations and "DMX signal" appears on the display.
2. Use the UP/DOWN keys to find the "Lmp_H" menu. The total number of hours the lamp has been lit will be displayed automatically.

3.6.1 Resetting the lamp elapsed time meter

Lmp_H

Each time a new lamp is fitted, it's possible to reset the meter indicating the elapsed time in order to have the real elapsed time for the lamp about to be fitted.

To reset the elapsed time meter, proceed as follows:

1. Connect Giotto Spot to the power supply, wait till it has completed reset operations and "DMX signal" appears on the display.
2. Use the UP/DOWN keys to find the "Lmp_H" menu.
3. Press ENTER to confirm. The message on the display will start to flash.
4. The DOWN key can be used to reset the meter.
5. On the contrary, pressing the UP key restores the previous value.
6. Press ENTER to confirm the changes.

3.7 Lamp strike meter

Lmp_st

The Giotto's microcomputer stores various data, including those relative to the number of lamp strikes. This information is important because needless lamp strikes causes stress to materials and components, so can contribute to reducing lamp life.

To know how many times a lamp has been ignited:

1. Connect Giotto Spot to the power supply, wait till it has completed reset operations and "DMX signal" appears on the display.
2. Use the UP/DOWN keys to find the ""Lmp_st"" menu. The number of lamp strikes will be displayed automatically.

3.7.1 Resetting the lamp strike meter

Lmp_st

Each time the fixture is relamped, it's possible to reset the meter which counts the strikes, in order to have number of actual strikes for the lamp about to be installed.

To reset the meter, proceed as follows:

1. Connect Giotto Spot to the power supply, wait till it has completed reset operations and "DMX signal" appears on the display.
2. Use the UP/DOWN keys to find the ""Lmp_st"" menu.
3. Press ENTER to confirm. The message on the display will start to flash.
4. The DOWN key can be used to reset the meter.
5. On the contrary, pressing the UP key restores the previous value.
6. Press ENTER to confirm the modifications.

3.8 Fixture operating time meter

SCN_h

This function allows to see for how many hours the fixture has been operating. This meter cannot be reset.

To see for how many hours the fixture has been used, proceed as follows:

1. Connect Giotto Spot to the power supply, wait till it has completed reset operations and "DMX signal" appears on the display.
2. Use the UP/DOWN keys to find the "Scn_H" menu. The number of fixture operating hours will be displayed automatically.

3.9 Input signal

SIGN=DMX

This function allows to choose the type of input signal to be used: DMX 512 or RS-232.

To select the required signal, proceed as follows:

1. Connect Giotto Spot to the power supply, wait till it has completed reset operations and "DMX signal" appears on the display.
2. Use the UP/DOWN key to find the "Sign=DMX" menu.
3. Press ENTER to confirm. The message on the display will start to flash.
4. Use the UP/DOWN keys to select the type of signal to be used.
5. Press ENTER to confirm the changes.

3.10 Pan/Tilt movement resolution

SMD=16

This function allows to define the movement resolution (16 or 8 bit). The difference is in the number of steps in which the range of head movement is divided. In 16-bit mode, 540° of Pan and 270° of Tilt are divided into 65,536 steps, ensuring very smooth precision even at very low speeds. In 8-bit mode, the number of steps is 256, which nevertheless allow precise movements.

1. Connect Giotto Spot to the power supply, wait till it has completed reset operations and "DMX signal" appears on the display.
2. Use the UP/DOWN keys to find the ""SMD"" menu.
3. Press ENTER to confirm. The message on the display will start to flash.
4. Use the UP/DOWN keys to select the type of resolution required.
5. Press ENTER to confirm the modifications.

3.11 Remote control of lamp ignition

Lmp_ctr=DS

Operators can decide if the ignition of the Giotto's lamp is to be controlled from a lighting console or be automatic.

To access this function, proceed as follows:

1. Connect Giotto Spot to the power supply, wait till it has completed reset operations and "DMX signal" appears on the display.
2. Use the UP/DOWN keys to find the "LMP_ctr" menu.
3. Press ENTER to confirm. The message on the display will start to flash.
4. Use the UP/DOWN keys to select the required option.
5. Press ENTER to confirm the modifications.

3.12 Remote control of fixture reset

RST_st=DS

Using this menu, it's possible to decide whether to reset the fixture via remote control or not. To enable this function, proceed as follows:

1. Connect Giotto Spot to the power supply, wait till it has completed reset operations and "DMX signal" appears on the display.
2. Use the UP/DOWN keys to find the "RST_ctr" menu.
3. Press ENTER to confirm. The message on the display will start to flash.
4. Use the UP/DOWN keys to select the required option.
5. Press ENTER to confirm the changes.



3.13 Control of the acceleration of movement speed

Speed=100%

Movement can be optimized by changing the speed (SPEED) and acceleration (ACCEL) parameters, obtain smooth fast or slow movements as required.

To optimize movement, proceed as follows:

Accel=Fast

1. Connect Giotto Spot to the power supply, wait till it has completed reset operations and "DMX signal" appears on the display.
2. Use the UP/DOWN keys to find the "Speed" or "Accel" menu.
3. Press ENTER to confirm. The message on the display will start to flash.
4. Use the UP/DOWN keys to select the required option.
5. Press ENTER to confirm the changes.

3.14 Display brightness

Bright=40%

Operators can select one of the brightness levels available for the Giotto display, which can be standard or very low. This option is intended for theatre and television use, where excessive brightness can be troublesome.

To change display brightness, proceed as follows:

1. Connect Giotto Spot to the power supply, wait till it has completed reset operations and "DMX signal" appears on the display.
2. Use the UP/DOWN keys to find the "Bright" menu.
3. Press ENTER to confirm. The message on the display will start to flash.
4. Use the UP/DOWN keys to select the required option from those available.
5. Press ENTER to confirm the modifications.

3.15 Display reading position

DspIFlip

When the fixture is mounted "upside down" on a structure, operators can turn the display through 180°, thus greatly facilitating the reading of the menus on the display.

To change the reading position, proceed as follows:

1. Connect Giotto Spot to the power supply, wait till it has completed reset operations and "DMX signal" appears on the display.
2. Use the UP/DOWN keys to find the "DspIFlip" menu.
3. Press ENTER to confirm. The message on the display will start to flash.
4. Use the UP/DOWN keys to select the required option.
5. Press ENTER to confirm the modifications.

3.16 DMX delay

DMXdly=20

This allows to set the for how many seconds the fixture's last operating settings are maintained should there be no DMX signal. This function is indispensable in those cases in which there is an accidental DMX failure.

To set the required time, proceed as follows:

1. Connect Giotto Spot to the power supply, wait till it has completed reset operations and "DMX signal" appears on the display.
2. Use the UP/DOWN keys to find the "DMXDLY" menu.
3. Press ENTER to confirm. The message on the display will start to flash.
4. Use the UP/DOWN keys to select the required time.
5. Press ENTER to confirm changes.

3.17 Locking/unlocking the shutter

CSHUTT=EN

This feature allows to disable or enable Shutter closure if PAN or TILT lose their position.

CSHUTT=DN

1. Connect Giotto Spot to the power supply, wait until it has finished reset procedure and "DMX signal" appears on the display.
2. Use the UP/DOWN keys to go to the "CSHUTT" menu
3. Press "Enter" and hold it down for a few seconds to confirm. The message on the display starts flashing.
4. Use the UP/DOWN keys to select "CSHUTT=EN" or "CSHUTT=DN" to enable or disable the closure of the shutter if the fixture is accidentally moved.
5. Press "Enter" to save the value set

3.18 Setting default parameters

FACT=Set

This feature allow to set the default parameters:

FACT=Off

1. Connect Giotto Spot to the power supply, wait until it has finished reset procedure and "DMX signal" appears on the display.
2. Use the UP/DOWN keys to go to the "FACT" menu.
3. Press "Enter" to confirm. The message on the display starts flashing.
4. Use the UP/DOWN keys to select "FACT=SET" and press "Enter".
5. By pressing "Enter" in this mode, the default parameters shown in the table are set and "FACT=OFF" appears on the display.

Menu Item	D fault Parameter
ADDR	001
Pmove	NORM
PP_mi	000 degrees
PP_max	540 degrees
Tmove	NORM
T_min	000 degrees
TP_max	265 degrees
SWAP	OFF
SIGN	DMX
SMD	16 BIT
LMP_ctr	DS
RST_ctr	DS
SPEED	100%
ACCEL	FAST
Bright	40%
DMXdly	UNL
CSHUTT	EN

3.19 Restoring default parameters

PREV=Set

This feature allows to reset the values of the parameters which were set immediately before FACT=SET procedure. In other words, if the default parameters have been set by mistake, this allows to return to the values previously set.

PREV=OFF

1. Connect Giotto Spot to the power supply, wait until it has finished reset procedure and "DMX signal" appears on the display.
2. Use the UP/DOWN keys to go to the "Prev" menu
3. Press "Enter" and hold it down for a few seconds to confirm. The message on the display starts flashing.
4. Use the UP/DOWN keys to select "PREV=SET"
5. Press "Enter" - this restores the values, cancelling the FACTORY DEFAULT operation. In the meantime, PREV starts flashing and PREV=OFF appears.

3.20 Setting the starting position of the rotating gobos and the gobo, colour and effects wheels

SETTING

From the Setting menu, it's possible to set the starting position of the colour, gobo and effects wheels, as well as the starting position of the rotating gobos. To carry out the setting, proceed as follows:

COL=1250

GOB=2200

RGOB=1600

EFF=3000

1. Connect Giotto Spot to the power supply, wait until it has finished reset procedure.
2. Use the UP/DOWN keys to go to the "SETTING" menu
3. Press "Enter".
4. Use the UP/DOWN keys to select "COL, GOB, RGOB, EFF"
5. Press "Enter" to select - the writing on the display will begin to flash.
6. Set the offset with the UP/DOWN keys
7. Press ENTER to confirm (the writing stops flashing) and return to the SETTING submenu
8. Once all the settings have been done, press ENTER for 4 seconds to exit the Setting menu.

3.21 Test functions

TEST

Test programs can be used in the event of it being necessary to check the correct operation of the fixture or some of its parts.

To selection the required test program, proceed as follows:

TEST=Reset

1. Connect Giotto Spot to the power supply, wait till it has completed reset operations and "DMX signal" appears on the display.
2. Use the UP/DOWN keys to find the "Test" menu.
3. Press ENTER and hold it down for a few seconds to confirm. The message on the display will start to flash.
4. Use the UP/DOWN keys to select the program corresponding to the part of the fixture to be tested.
5. Press ENTER to run the test program.
6. To quit the test functions, press ENTER once, then press it again for a few seconds until "Test" re-appear on the display.

3.22 Reserved functions

Reserved

Some fixture functions can't be accessed by operators as they regard software sections as yet be defined in this firmware release. When RESERVED appears on the display, you're in this section. Access is forbidden.

4.0 Control channels

DMX Channel	Function	Description
Ch1	Pan MSB	High Pan byte - in 8-bit operation, only this byte is sent
Ch2	Pan LSB	Low Pan byte for 16-bit positioning
Ch3	Tilt MSB	High Tilt byte - in 8-bit operation only this byte is sent
Ch4	Tilt LSB	Low Tilt byte for 16-bit positioning
Ch5	Iris	Iris aperture control
Ch6	Color	9 color combinations over the entire channel+rainbow+music change run
Ch7	Gobos	8 Gobos+gobos scrolling+music change
Ch8	Shutter/Strobe	Shutter and strobe with music sync / Black-out gobo and colour change
Ch9	Dimmer	Mechanical dimmer
Ch10	Gobo Rotation	Indexable position and rotation in both directions with adjustable speed
Ch11	Prisms	Allows the insertion of either of the two rotary prisms or neither
Ch12	Rotation Prisms	Regulation of prism rotation speed in one direction or the other
Ch13	Electronic Focus	Enables lens to be focussed
Ch14	Zoom	Widenin /narrowing of light beam (9°-24°)
Ch15	Effects	Effects conversion filters
Ch16	Frost	Variable frost filter
Ch17	Mspeed	Movement speed Controlled crossfade Slow Fast
Ch18	Reset Lamp	
Ch19	Gobo shake	Gobo oscillation adjustable speed
Ch20	Mod_colore	Indexable position, Full color hard change, Half color hard change, 8-speed Rainbow, Music sync color change
Ch21	Mod_rot.gobo	Indexable gobo position, gobo rotation, gobo shaker
Ch22	Macro	Macro Functions

4.1 Iris channel -ch 5-

Adjustable using channel 5, gives linear variation of beam diameter. Diaphragm features include high opening/closing speed and low noise.

DMX VALUE	FUNCTION
0	MINIMUM APERTURE
0 - 255	LINEAR VARIATION
255	MAXIMUM APERTURE

4.2 Color channel -ch 6-

Giotto Spot is fitted with a color wheel comprising 9 dichroic filters. Color changes are controlled via channel 6, whereas 'color mode' is selected via channel 20. 5 different modes can be selected. (ref. CH20).

With Color Mode CH20 = FULL COLOR

DMX VALUE	CENTRE VALUE	FUNCTION	POS.
0 - 27	14	WHITE	0
28 - 55	41	RED	1
56 - 83	68	YELLOW	2
84 - 111	97	GREEN	3
112 - 139	125	CYAN	4
140 - 167	153	BLUE	5
168 - 195	181	MAGENTA	6
196 - 223	209	AZURE	7
224 - 255	239	ORANGE	9

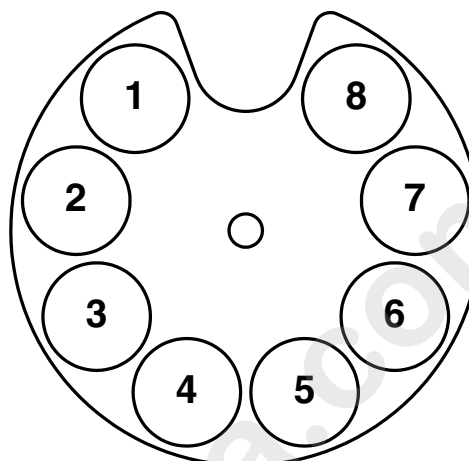

With Color Mode CH20 = HALF COLOR

DMX VALUE	CENTRE VALUE	FUNCTION
0 - 24	12	WHITE
25 - 49	37	WHITE/RED
50 - 74	62	RED/YELLOW
75 - 99	87	YELLOW/GREEN
100 - 124	112	GREEN/CYAN
125 - 149	137	CYAN/BLUE
150 - 174	162	BLUE/MAGENTA
175 - 200	187	MAGENTA/ AZURE
201 - 225	212	AZURE / ORANGE
226 - 255	237	OR NGE WHITE

With Color Mode CH20 = SOFT COLOR

DMX51 Level Rang	Centre Color Level	FUNCTION
Indexed Color Linear color regulation in every field	0	WHITE
	28	RED
	56	YELLOW
	84	GREEN
	112	CYAN
	140	BLUE
	168	MAGENTA
	196	AZURE
	224	ORANGE

With Color Mode CH20 = SOFT RAINBOW

DMX VALUE	CENTRE VALUE	FUNCTION
0 -15	8	SPEED 1
16 - 31	24	SPEED 2
32 - 47	40	SPEED 3
48 - 63	56	SPEED 4
64 - 79	72	SPEED 5
80 - 95	88	SPEED 6
96 - 111	104	SPEED 7
112 - 127	120	SPEED 8
128 - 143	136	SPEED 9
144 - 159	152	SPEED 10
160 - 175	168	SPEED 11
176 - 191	184	SPEED 12
192 - 207	200	SPEED 13
208 - 223	216	SPEED 14
224 - 239	232	SPEED 15
240 - 255	248	SPEED 16

With Color Mode CH 20=MUSIC HARD CHANGE

DMX VALUE	FUNCTION
0 - 127	HARD MUSIC CHANGE FULL COLOR
128 - 255	HARD MUSIC CHANGE HALF COLOR

4.3 Gobo channel -ch 7-

Gobos are selected using channel 7. The gobo group comprises a wheel with 8 rotary gobos and an open position. Gobos are all easily replaced and it's also possible to synchronize gobo changes with a musical bass beat, in which case, gobo selection is random and in any case not synchronized on the various fixtures.

The gobos on the rotary wheel can rotate both clockwise and counter clockwise and their positions can be stored if this is foreseen.

DMX VALUE	CENTRE VALUE	FUNCTION
0 - 20	10	WHITE
21 - 41	31	GOBO1
42 - 62	52	GOBO2
63 - 83	73	GOBO3
84 - 104	94	GOBO4
105 - 125	115	GOBO5
126 - 146	136	GOBO6
147 - 167	157	GOBO7
168 - 189	178	GOBO8
190 - 196	193	SCROLLING SPEED 1
197 - 203	200	SCROLLING SPEED 2
204 - 210	207	SCROLLING SPEED 3
211 - 217	214	SCROLLING SPEED 4
218 - 224	221	SCROLLING SPEED 5
225 - 231	228	SCROLLING SPEED 6
232 - 238	235	SCROLLING SPEED 7
239 - 245	242	SCROLLING SPEED 8
246 - 255	252	GOBOS MUSIC CHANGE



side towards the lamp

SGM reserves the right to modify any specifications without prior notice.

4.4 Shutter/strobe channel - ch 8-

The Shutter/Strobe can be regulated via channel 8. The mechanism which enables the strobe effect to be generated is the same as that used for dimming the light beam, however it's also possible to control the light's intensity while the strobe's enabled. It also enables instantaneous blackout without any light spill. High impact visual effects such as strobe effects in sync with the bass notes and blackout during color and gobo changes can be obtained using this channel.

DMX VALUE	CENTRE VALUE	FUNCTION
0 - 7	4	Closed
8 - 15	12	Strobe at frequency of 1Hz
16 - 23	20	Strobe at frequency of 1.38 Hz
24 - 31	28	Strobe at a frequency of 1.6 Hz
32 - 39	36	Strobe at a frequency of 1.9 Hz
40 - 47	44	Strobe at a frequency of 2.3 Hz
48 - 55	52	Strobe at a frequency of 2.7 Hz
56 - 63	60	Strobe at a frequency of 3.4 Hz
64 - 71	68	Strobe at a frequency of 4 Hz
72 - 79	76	Strobe at a frequency of 5 Hz
80 - 87	84	Strobe at a frequency of 6 Hz
88 - 95	92	Strobe at a frequency of 7 Hz
96 - 103	100	Strobe at a frequency of 8 Hz
104 - 111	108	Strobe at a frequency of 9 Hz
112 - 119	116	Strobe at a frequency of 10 Hz
120 - 136	128	Shutter strobe low strobe effect at maximum frequency in sync with bass notes
137 - 153	145	Music flash low
154 - 170	162	Autoshade open on the gobos
171 - 187	179	Autoshade open on the colors
188 - 204	196	Autoshade open on the gobos and colors
205 - 221	213	Open with slow gobo change
222 - 255		Open

4.5 Dimmer –ch 9-

Adjustable via channel 9, allows linear regulation of luminous power. Giotto's dimmer is mechanical and ensures good linear adjustment as well as high operating speed and very low noise.

DMX512 Level range 0–255	FUNCTION
0 – 255	0 – 100% LINEAR REGULATION

4.6 Gobo rotation -ch 10-

By means of this channel, it's possible to control rotation speed or positioning of the rotary gobos. Rotation can be in either direction at variable speed (adjustable from a minimum of 0.1 rpm to a maximum of 55 rpm) and gobos' positions can set over a range of 360°. This gobo system ensures absolutely smooth rotation. By means of channel 21 the required operating mode can be selected:

With Gobo Rotation Mode (Ch21) =Gobo position indexing

DMX512 Level range 0–255	FUNCTION
0...255	Linear regulation of gobo position over the full 360°

With Gobo Rotation Mode (Ch21) =Gobo rotation at adjustable speed in both directions

DMX512 Level range 0–255	FUNCTION
0...111	CLOCKWISE ROTATION [MAX... MIN]
112 – 144	STOPPED
145...255	COUNTER CLOCKWISE ROTATION [MIN...MAX]



4.7 Prisms -ch 11-

By means of this channel it's possible to select the fixture's two rotary prisms, which allow to multiply projected images by four, ensuring eye-catching graphic/decorative effects. The prisms can't be superimposed, so must be selected individually. Lastly, the system prism is completely independent from the gobo system, which means they can be combined.

DMX512 Level range 0–255	FUNCTION
0 – 84	NO PRISM INSERTED
85 – 170	COMET
171 – 255	4-FACET PRISM (14° BEAM)

4.8 Prism rotation -ch 12-

By means of this channel it's possible to control the rotation speed of the fixture's two rotary prisms.

DMX512 Level range 0–255	FUNCTION
0 ... 111	CLOCKWISE ROTATION [MAX...MIN]
112 – 143	STOPPED
144 ... 255	COUNTER CLOCKWISE ROTATION [MIN... MAX]

4.9 Electronic focus -ch 13-

This channel is used for precise linear focussing, ensuring well-defined projections at any distance, or eye-catching blurred effects. **IMPORTANT!! For correct electronic focus operation, fit the dichroic gobos with their coated side outwards.**

DMX512 Level range 0255	FUNCTION
0 - 255	0 - 100% LINEAR REGULATION

4.10 Zoom -ch 14-

By means of this channel it's possible to widen or narrow the light beam from 9° to 24°. When the zoom is used, gobos remain in focus.

DMX VALUE	FUNCTION
0	ZOOM IN (9° ANGLE)
0 - 255	LINEAR VARIATION
255	ZOOM OUT (24° ANGLE)

4.11 Effects wheel -ch 15-

The effects wheel comprises 7 fixed gobos and an open position. The gobos fitted on this wheel can be combined with the rotary ones on the gobo wheel.

DMX VALUE	CENTRE VALUE	FUNCTION	POS
0 - 27	14	WHITE	-
28 - 55	41	TUNNEL	1
56 - 83	68	STRIPPED TEXTURE	2
84 - 111	97	HONEYCOMB TEXTURE	3
112 - 139	125	SPIDER	4
140 - 167	153	WOOD FILTER	5
168 - 195	181	FILTER 1/2CTO	6
196 - 223	209	FILTER CTO	7
224 - 255	239	AMBER	8

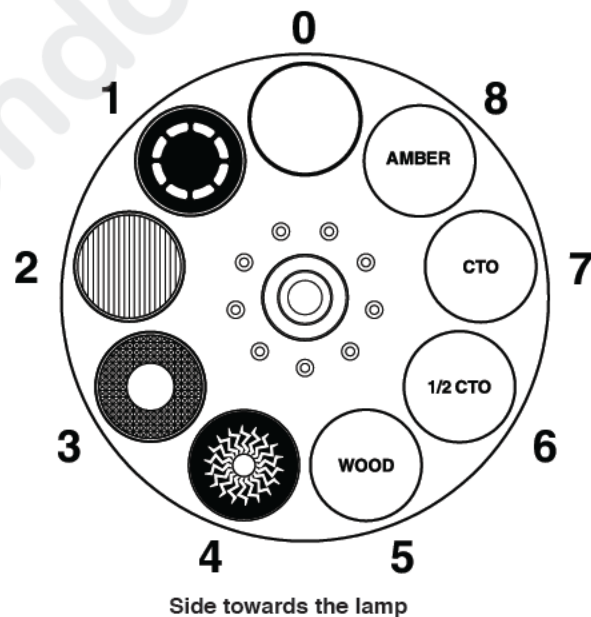

SGM reserves the right to modify any specifications without prior notice.

4.12 Frost -ch 16-

Adjusted using channel 16, gives linear variable frost.

DMX VALUE	FUNCTION
0	FROST DISABLED
0 - 255	LINEAR VARIATION
255	FROST FULLY INSERTED

4.13 Mspeed –ch 17-

Mspeed affects PAN and TILT and is intended as the time required to complete a movement from one position to another. This means that the fixtures with the same Mspeed value will reach destination at the same instant. It's therefore possible to set movement times for each fixture which are independent of the times sent by the lighting console. The DMX values between 000-003 allow the console to control the movement, whereas with DMX value 004 a time can be allocated to the movement. To find Mspeed times, refer to the conversion table.

DMX VALUE	FUNCTION
0 -- 3	Controller crossfade
4 ... 255	Slowest ... Fastest

4.14 Remote lamp striking and reset -ch 18-

The ignition (or dousing) of the lamp can be controlled via DMX using a lighting console. In fact, after having switched on the Giotto, the lamp remains off until it receives a "lamp strike" command. This function has no effect if it's not enabled by means of the fixture's built-in microcomputer. In this case, the lamp will ignite automatically without waiting to receive the command from the lighting console. Should the lamp be accidentally switched off, it's advisable to wait at least 5 minutes before sending the ignition command. However, if the command is sent sooner, Giotto Spot will ignite the lamp by running restrike attempts at regular 3-minute intervals.

Lastly, Giotto Spot has a function which automatically reduces lamp power by 50% every time shutter or dimmer is closed. This function ensures considerably better fixture cooling and increases lamp life. The lamp obviously returns to full power when the shutter or dimmer are reopened.

Should any problems occur, a reset command can be sent to the fixture in order that all the motors return to their starting positions before continuing to execute commands received from the console.

DMX512 Level range 0-- 255	FUNCTION	
0 - 60	Off	LAMP
61 - 129	Hysteresis	
130 - 179	On	
180 - 239	Hysteresis	ESET
240 - 255	Reset	

4.15 Goboshake –ch 19-

The Goboshake effect vibrates the gob on a centre position and any of 16 different speeds can be selected.

DMX VALUE	CENTRE VALUE	FUNCTION
0 - 47	23	Goboshake disabled
48 - 60	54	Goboshake Speed 1
61 - 73	67	Goboshake Speed 2
74 - 86	80	Goboshake Speed 3
87 - 99	93	Goboshake Speed 4
100 - 112	106	Goboshake Speed 5
113 - 125	119	Goboshake Speed 6
126 - 138	132	Goboshake Speed 7
139 - 151	145	Goboshake Speed 8
152 - 164	158	Goboshake Speed 9
165 - 177	171	Goboshake Speed 10
178 - 190	184	Goboshake Speed 11
191 - 203	197	Goboshake Speed 12
204 - 216	210	Goboshake Speed 13
217 - 229	223	Goboshake Speed 14
230 - 242	236	Goboshake Speed 15
243 - 255	249	Goboshake Speed 16

4.16 Color mode -ch 20-

Used in combination with channel 6. From here it's possible to select the color wheel's operating 'mode'.

DMX VALUE	VALUE CENTRE	FUNCTION	
0 - 50	25	FULL COLOR	Digital regulation of the colors on centre positions
51 - 101	75	HALF COLOR	Digital regulation of the colors on intermediate positions
102 - 152	125	SOFT COLOR	Analog color selection on each position
153 - 203	175	SOFT RAINBOW	Continuous color rotation at adjustable speed
204 - 255	225	HARD MUSIC CHANGE	Digital color change in sync with bass notes

4.17 Gobo mode -ch 21-

Used in combination with Channel 10 - from here, it's possible to select the gobo wheel's operating 'mode'.

DMX512 Level range 0-255	FUNCTION
0...127	GOBO POSITION INDEXING
128...255	GOBO ROTATION AT ADJUSTABLE SPEED IN BOTH DIRECTIONS



4.18 Macro –ch 22-

From this channel it's possible to select one of the 16 preset Macros

DMX VALUE	CENTRAL VALUE	DESCRIPTION	CHANNELS USED
0-7	4	No Macro	
8-15	12	Slow dimmer opening ramp and fast closing	Dimmer Shutter
16-23	20	Slow dimmer closing ramp and fast opening	Dimmer Shutter
24-31	28	Odd-numbered fixtures run a slow dimmer opening ramp. Even-numbered fixtures run a slow dimmer closing ramp	Dimmer Shutter
32-39	36	Odd-numbered fixtures run a slow dimmer opening ramp and even-numbered fixtures' shutters are closed. Then even-numbered fixtures run a slow dimmer opening ramp and odd-numbered fixtures' shutters are closed.	Dimmer Shutter
40-47	44	Odd-numbered fixtures run a slow dimmer closing ramp while even-numbered fixtures' shutters are open. Then even-numbered fixtures run a slow dimmer closing ramp and even-numbered fixtures' shutters are open	Dimmer Shutter
48-55	52	Slow iris opening ramp and fast closing	Iris
56-63	60	Slow iris closing ramp and fast opening	Iris
64-71	68	Fast iris closing and opening	Iris
72-79	76	Odd-numbered fixtures run a slow iris opening ramp, even-numbered fixtures run a slow iris closing ramp	Iris
80-87	84	Odd-numbered fixtures run a slow iris opening ramp whereas even-numbered fixtures' irises are closed. Then even-numbered fixtures run a slow iris opening ramp and even-numbered fixtures' irises are closed	Iris
88-95	92	Odd-numbered fixtures run a slow iris closing ramp whereas even-numbered fixtures' irises are open. Then even-numbered fixtures run a slow iris closing ramp and odd-numbered fixtures' irises are open	Iris
96-103	100	Even-numbered fixtures close their irises, whereas odd-numbered fixtures open them and vice versa	Iris
104-111	108	Random strobe	Shutter
112-119	116	Slow Frost insertion ramp followed by slow removal ramp	Frost
120-127	124	Slow Frost insertion ramp followed by fast removal	Frost
128-135	132	Slow Frost insertion ramp on even-numbered fixtures, whereas Frost is disabled on odd-numbered units. Then slow Frost insertion ramp on odd-numbered fixtures and Frost disabled on even-numbered fixtures	Frost
136-143	140	Reserved for future use	-
144-151	148	Reserved for future use	-
152-159	156	Reserved for future use	-
160-167	164	Reserved for future use	-
168-175	172	Reserved for future use	-
176-183	180	Reserved for future use	-
184-191	188	Reserved for future use	-
192-199	196	Reserved for future use	-
200-207	204	Reserved for future use	-
208-215	212	Reserved for future use	-
216-223	220	Reserved for future use	-
224-231	228	Reserved for future use	-
232-239	236	Reserved for future use	-
240-247	244	Reserved for future use	-
248-255	252	Reserved for future use	-

*SGM reserves the right to modify any specifications without prior notice.

Conversion table

DMX VALUE	MSPEED (in seconds)	DMX VALUE	MSPEED (in seconds)	DMX VALUE	MSPEED (in seconds)	DMX VALUE	MSPEED (in seconds)
0 -- 1	cross fade	65	150	129	72	193	17
2	cross fade	66	149	130	70	194	17
3	cross fade	67	147	131	69	195	16
4	243	68	146	132	68	196	16
5	241	69	145	133	67	197	15
6	240	70	143	134	66	198	15
7	238	71	142	135	65	199	14
8	236	72	141	136	64	200	14
9	234	73	139	137	63	201	13
10	233	74	138	138	62	202	13
11	231	75	137	139	61	203	12
12	229	76	135	140	60	204	12
13	227	77	134	141	59	205	12
14	226	78	133	142	58	206	11
15	224	79	131	143	57	207	11
16	222	80	130	144	56	208	10
17	221	81	129	145	55	209	10
18	219	82	128	146	54	21	10
19	217	83	126	147	53	11	9
20	216	84	125	148	52	21	9
21	214	85	124	149	51	213	9
22	213	86	122	150	50	14	8
23	211	87	121	151	49	215	8
24	209	88	120	152	8	216	8
25	208	89	119	153	47	217	7
26	206	90	117	154	46	218	7
27	205	91	116		45	219	7
28	203	92	115	156	45	220	6
29	202	93	114	1 7	44	221	6
30	200	94	112	158	43	222	6
31	199	95	111	159	42	223	6
32	197	96	11	160	41	224	5
33	195	97	109	161	40	225	5
34	194	98	1 8	162	39	226	5
35	192	9	106	163	38	227	5
36	191	00	105	164	38	228	4
37	189	101	104	165	37	229	4
38	188	02	103	166	36	230	4
39	18	103	101	167	35	231	4
40	185	104	100	168	34	232	4
41	184	105	99	169	34	233	3
42	1 2	106	98	170	33	234	3
43	181	107	97	171	32	235	3
44	179	108	95	172	31	236	3
45	178	109	94	173	30	237	3
46	176	110	93	174	30	238	3
47	175	111	92	175	29	239	3
48	173	112	91	176	28	240	2
49	172	113	90	177	28	241	2
50	171	114	88	178	27	242	2
51	169	115	87	179	26	243	2
52	168	116	86	180	25	244	2
53	166	117	85	181	25	245	2
54	165	118	84	182	24	246	2
55	164	119	83	183	23	247	2
56	162	120	82	184	23	248	2
57	161	121	80	185	22	249	2
58	159	122	79	186	22	250	2
59	158	123	78	187	21	251	2
60	157	124	77	188	20	252	2
61	155	125	76	189	20	253	2
62	154	126	75	190	19	254	2
63	153	127	74	191	19	255	2
64	151	128	73	192	18		





SGM Elettronica srl
Via Pio La Torre, 1 • 61010 Tavullia (PS), Italy
Tel. +39 0721 476477 • Fax +39 0721 476170
e-mail: info@sgm.it • <http://www.sgm.it>