

ROBE

ROBIN[®] miniPointe

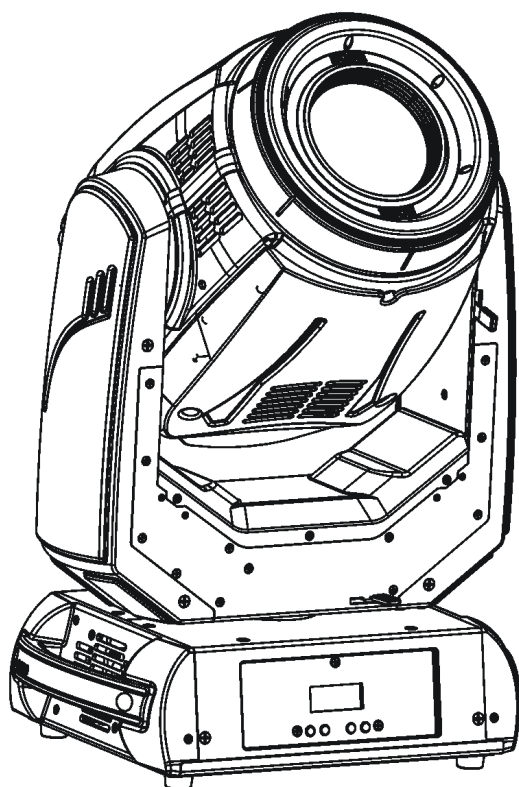

 **ROBIN[®]**
Innovative Technology

USER MANUAL

ROBE[®] lighting s.r.o. • Czech Republic • www.robe.cz

Robin miniPointe

Table of contents

1. Safety instructions	3
2. Fixture exterior view	5
3. Installation	6
3.1 Connection to the mains	6
3.2 Changing the lamp	7
3.3 Lamp adjustment	8
3.4 Rigging the fixture	10
3.5 DMX-512 connection.....	12
3.6 Wireless DMX operation	13
3.7 Replacing colour filters	14
4. Remotely controllable functions	15
5. Control menu map	16
6. Control menu	19
6.1 Addressing (DMXA)	19
6.2 Fixture information (Info)	19
6.3 Personality (Pers).....	20
6.4 Lamp on/off (Lamp).....	21
6.5 Manual Control (Manual).....	21
6.6 Test program (Test Prg).....	22
6.7 Stand-alone (St Alone).....	22
6.8 Reset (Reset)	23
6.9 Special functions (Special).....	23
7. RDM	25
8. Error and information messages	26
9. Technical Specifications	28
10. Maintenance and cleaning	31
11. ChangeLog	31

**FOR YOUR OWN SAFETY, PLEASE READ THIS USER MANUAL CAREFULLY
BEFORE YOU INITIAL START - UP**

This device has left our premises in absolutely perfect condition. In order to maintain this condition and to ensure a safe operation, it is absolutely necessary for the user to follow the safety instructions and warning notes written in this manual.

The manufacturer will not accept liability for any resulting damages caused by the non-observance of this manual or any unauthorized modification to the device.

Please consider that damages caused by manual modifications to the device are not subject to warranty.

The Robin miniPointe was designed for indoor use and it is intended for professional application only. It is not for household use.

1. Safety instructions

CAUTION!

Disconnect the fixture from mains before you remove any cover of the fixture. With a high voltage you can suffer a dangerous electric shock when touching alive wires and electrical parts under covers!

Make sure that the available voltage is not higher than stated on the rear panel of the fixture. This fixture should be operated only from the type of power source indicated on the marking label. If you are not sure of the type of power supplied, consult your authorized distributor or local power company.

Always disconnect the fixture from AC power before cleaning, removing or installing the fuses, or any part.

The power plug has to be accessible after installing the fixture. Do not overload wall outlets and extension cords as this can result in fire or electric shock.

Do not allow anything to rest on the power cord. Do not locate this fixture where the cord may be damaged by persons walking on it.

Make sure that the power cord is never crimped or damaged by sharp edges. Check the fixture and the power cord from time to time.

Refer servicing to qualified service personnel.

This fixture falls under protection class I. Therefore this fixture has to be connected to a mains socket outlet with a protective earthing connection.

Do not connect this fixture to a dimmer pack.

During the initial start-up some smoke or smell may arise. This is a normal process and does not necessarily mean that the device is defective.

Do not touch the device's housing bare hands during its operation (housing becomes hot)!

For replacement use lamps and fuses of same type and rating only.

**CAUTION ! EYE DAMAGES !
Avoid looking directly into the light source!**

If the fixture has been exposed to drastic temperature fluctuation (e.g. after transportation), do not switch it on immediately. The arising condensation water might damage your device. Leave the device switched off until it has reached room temperature.

Do not shake the fixture. Avoid brute force when installing or operating the fixture.

This fixture was designed for indoor use only, do not expose this unit to rain or use near water.

When choosing the installation spot, please make sure that the fixture is not exposed to extreme heat, moisture or dust.

Air vents and slots in the fixture's head and base are provided for ventilation, to ensure reliable operation of the device and to protect it from overheating.

Do not block the front objective lens with any object when the fixture is under operation.

The openings should never be covered with cloth or other materials, and never must be blocked.

The fixture becomes very hot during operation. Allow the fixture to cool approximately 20 minutes prior to manipulate with it.

Before switching the fixture OFF, turn the lamp OFF and allow the fixture to cool for a while.

This fixture should not be placed in a built-in installation unless proper ventilation is provided.

Only operate the fixture after having checked that the housing is firmly closed and all screws are tightly fastened.

Always use a secondary safety cable when mounting this fixture.

Make sure that the area below the installation place is blocked when rigging, derigging or servicing the fixture.

Warning
The minimum distance between light output and the illuminated surface must be more than 5 meters.

The maximum ambient temperature 45°C must never be exceeded.

CAUTION!
The front lens has to be replaced when it is obviously damaged, so that its function is impaired, e. g. due to cracks or deep scratches!

Operate the device only after having familiarized with its functions. Do not permit operation by persons not qualified for operating the device. Most damages are the result of unprofessional operation!

CAUTION!
The lamp has to be replaced when it is damaged or deformed due to the heat!

Please use the original packaging if the device is to be transported.

CAUTION!
Fast on-off-cycles (e.g. 10 min. on / 10 min. off) will reduce lamp life.

CAUTION!
To avoid damage of the internal parts of the fixture head, never let the sunlight lights directly to the front lens , even when the fixture is not working !

2. Fixture exterior view

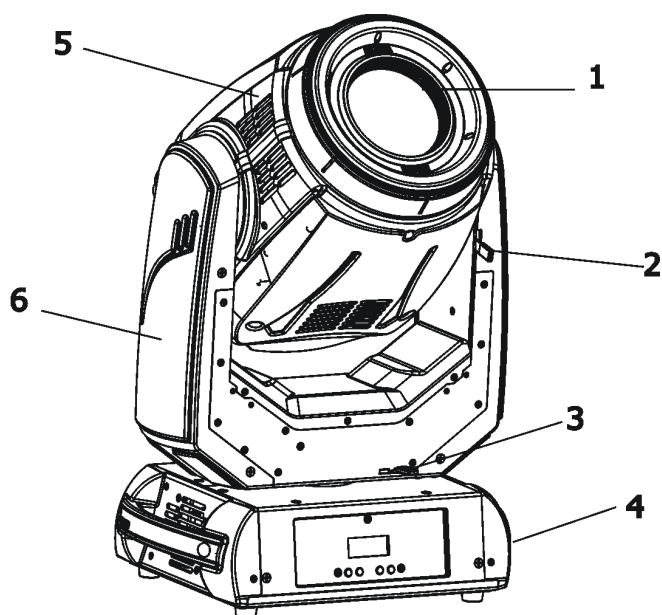

- 1 - Front lens
- 2 - Tilt lock
- 3 - Pan lock
- 4 - Base
- 5 - Moving head
- 6 - Arm

The head should be locked for transportation- the tilt lock (2) and the pan lock (3) have to be in the locked positions. To unlock the head, move these latches to unlock positions before operating the fixture.

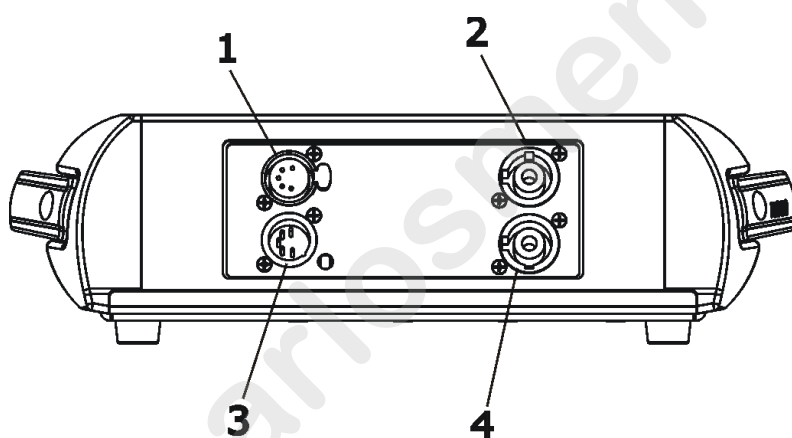

Rear panel of the base:

- 1 - 5-pin DMX Out
- 2 - Power Out
- 3 - 5-pin DMX In
- 4 - Power In

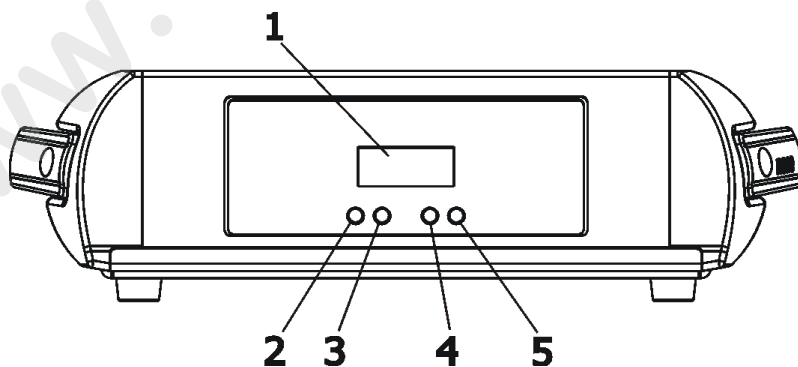

Front panel of the base:

- 1 - Display
- 2 - ESCAPE button
- 3 - ENTER button
- 4 - NEXT button
- 5 - PREV button

The ENTER/DISPLAY ON button also serves for switching the display on when the fixture is disconnected from the mains.

3. Installation



Fixtures must be installed by a qualified electrician in accordance with all national and local electrical and construction codes and regulation.

3.1 Connection to the mains

For protection from electric shock, the fixture must be earthed!

The Robin miniPointe is equipped with auto-switching power supply that automatically adjusts to any 50-60Hz AC power source from 100-240 Volts. This fixture must be earthed. To use the fixture, a plug must be fixed. The correct assembly of a sufficient plug may be done by professional persons only. The conductors in the cable are marked by the following table.

Core (EU)	Core (US)	Connection	Plug Terminal Marking
Brown	Black	Live	L
Light blue	White	Neutral	N
Green /Yellow	Green	Earth	

Design of the Robin miniPointe allows to connect several fixtures to AC mains power in one interconnected daisy chain using power input and throughput connectors. Needed daisy chain cords are stated in the chapter "Technical specifications "

The max. number of connected fixtures depends on the AC mains power voltage and fixture version:

EU version (CE)

15 fixtures at power supply= 230V

13 fixtures at power supply= 208V

7 fixtures at power supply= 120V

US version (cETLus)

9 fixtures at power supply= 230V

7 fixtures at power supply= 208V

5 fixtures at power supply= 120V

Do not overload the supply line and the connecting leads.

Wiring and connection work must be carried out by qualified staff!

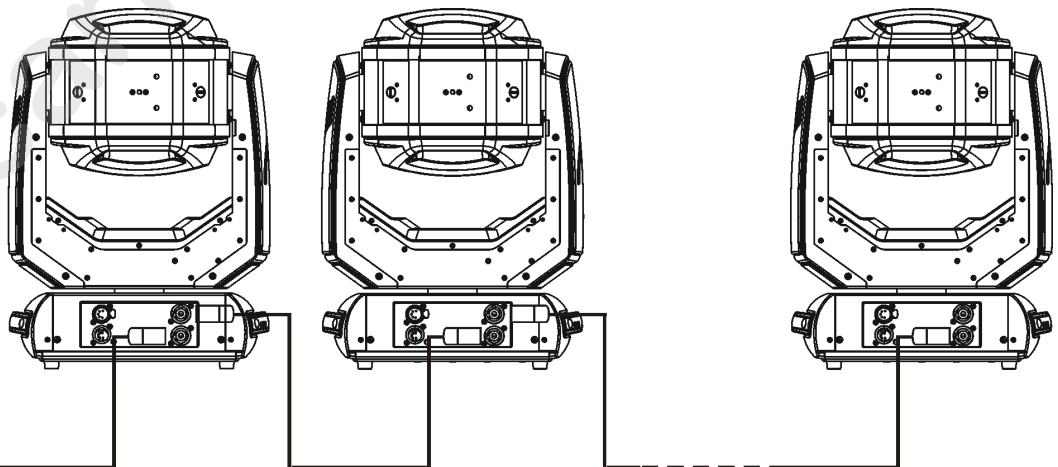

Supply lead

3.2 Changing the lamp

DANGER !
Install the lamp with the fixture unplug from mains !

To insert the new lamp.

1. Disconnect the fixture from mains and allow it to cool at least 20 minutes.
2. Loosen the two quarter-turn fasteners (1) on a lamp cover and remove the lamp cover (2) to get into lamp compartment.
3. Remove both Fastons (3) from flat blades of the lamp.
4. Holding the lamp by its ceramic base (4), carefully pull the lamp outwards until you break force of spring locks (5) keeping the lamp in the lamp compartment.
5. Holding the new lamp by its ceramics base (4), gently insert the lamp into lamp compartment until it snaps into spring locks (5).

Do not install a lamp with a higher wattage! A lamp like this generates temperatures the device is not designed for. Damages caused by non-observance are not subject to warranty. Please follow the lamp manufacturer's notes!

Warning: do not touch the lamp's envelope with bare hands. Should this happen, clean the bulb with a cloth soaked in alcohol and dry it

6. Slide both Fastons (3) on lamp blades and check this connection
7. Re-insert the lamp cover (2) and tighten the two quarter-turn fasteners (1) .
8. Connect the fixture to the mains.
9. Reset the "Lamp On Time" and "Lamp Strikes" counters in the menu "Information".

Never operate this fixture without the lamp!
Do not operate this fixture without the lamp cover!

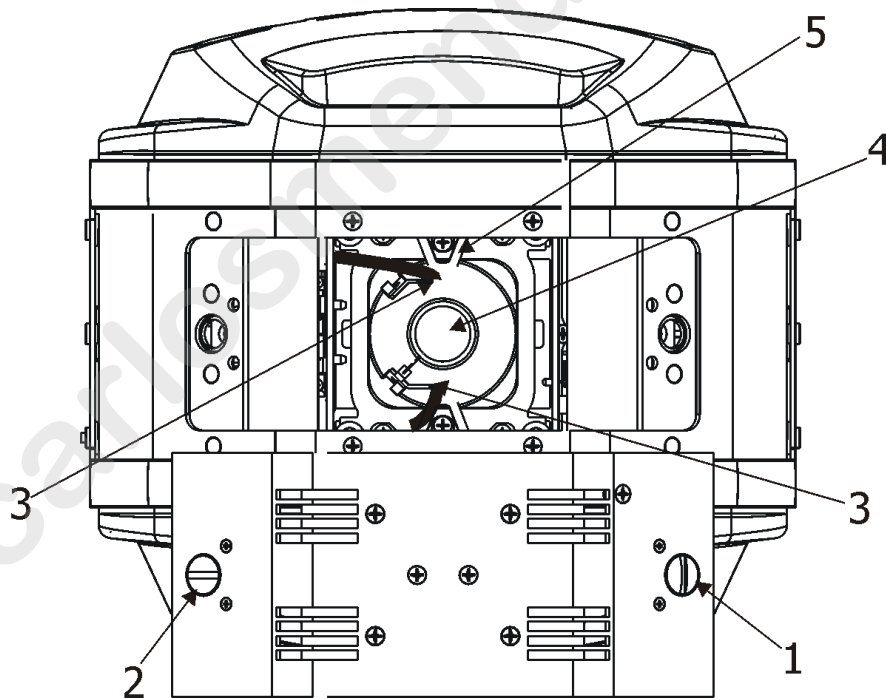

3.3 Lamp adjustment

The lamp holder is aligned at the factory. Due to differences between lamps, the fine adjustment may improve light performance.

For lamp adjustment serve four slots in the lamp assembly.

Slots A - for adjustment of the lamp horizontally

Slots B - for adjustment of the lamp vertically

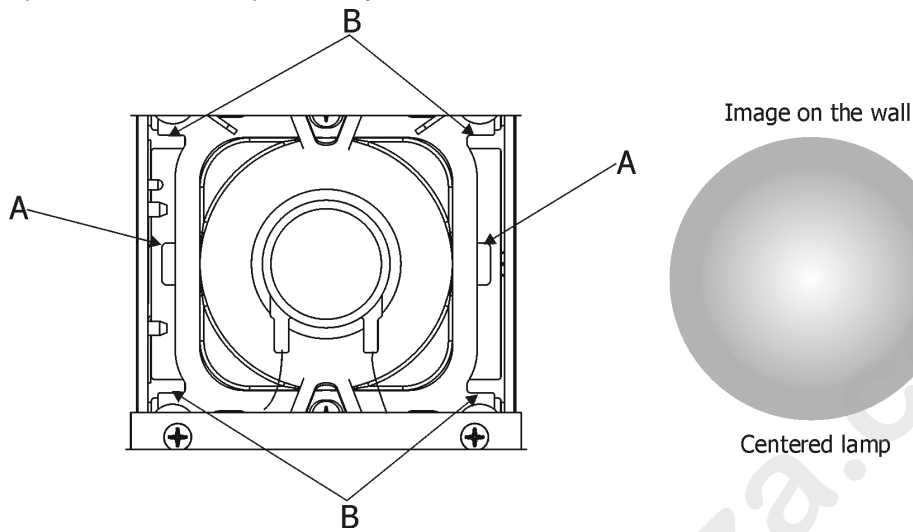

To adjust the lamp in the fixture.

1. Connect the fixture to the mains, switch on the lamp, open shutter and dimmer, set focus (Static gobo wheel should be set at 0 DMX) and check the image on the wall
2. Disconnect the fixture from mains.
3. Loosen two quarter-turn fasteners (1) on a lamp cover and remove the lamp cover (2) to get into lamp compartment.
4. Move the lamp into desired position by using a suitable screwdriver inserted in the appropriate slots (A, B).
5. Re-insert the lamp cover (2) and tighten the two quarter-turn fasteners (1).
6. Connect the fixture to the mains and check if the adjustment has been correctly made.
7. If you need to continue in adjusting, disconnect the fixture from mains and repeat steps 2-5.

**The lamp must be adjusted with the fixture disconnected from mains!
Do not operate this fixture without the lamp cover!**

Note: Due to light refraction in the fixture, the lamp has to be moved into direction of shifted hot-spot - see pictures below.

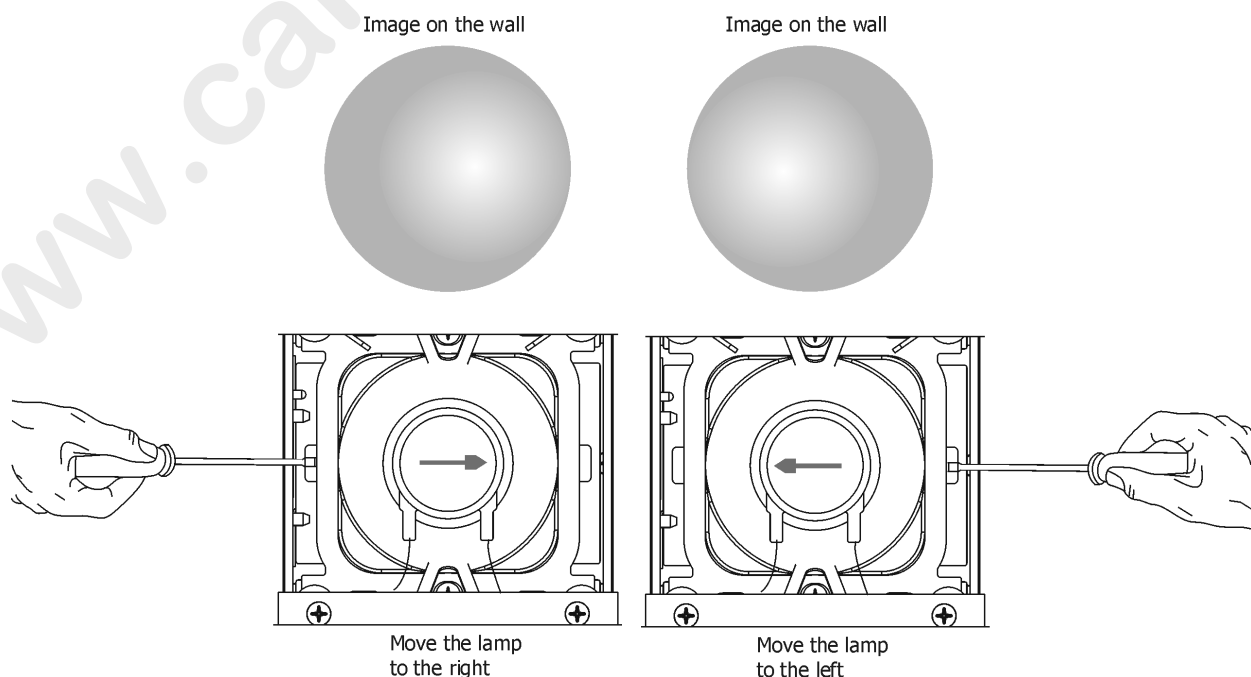
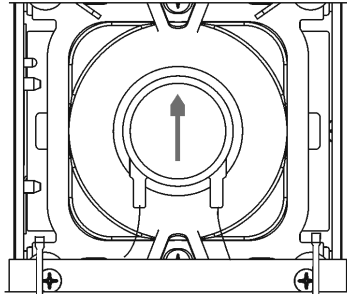
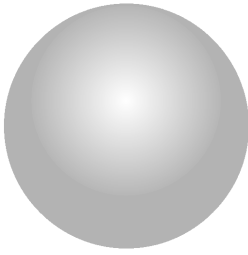
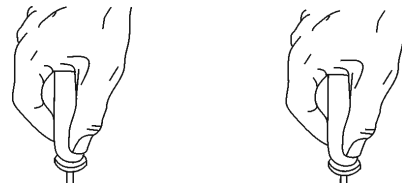
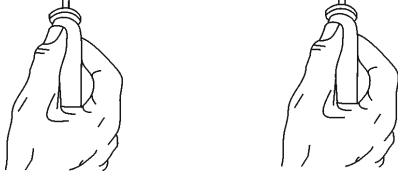

Image on the wall



Move the lamp
up



Move the lamp
down

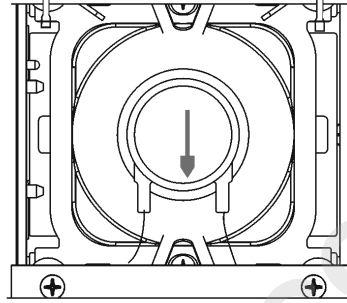

Image on the wall



3.4 Rigging the fixture

A structure intended for installation of the fixture (s) must safely hold weight of the fixture(s) placed on it. The structure has to be certificated to the purpose.

The fixture (fixtures) must be installed in accordance with national and local electrical and construction codes and regulation.

For overhead installation, the fixture must be always secured with a safety wire

When rigging, derigging or servicing the fixture staying in the area below the installation place, on bridges, under high working places and other endangered areas is forbidden.

The operator has to make sure that safety-relating and machine-technical installations are approved by an expert before taking into operation for the first time and after changes before taking into operation another time.

The operator has to make sure that safety-relating and machine-technical installations are approved by a skilled person once a year.

Allow the fixture to cool for ten minutes before handling.

The projector should be installed outside areas where persons may walk by or be seated.

IMPORTANT! OVERHEAD RIGGING REQUIRES EXTENSIVE EXPERIENCE, including calculating working load limits, installation material being used, and periodic safety inspection of all installation material and the projector. If you lack these qualifications, do not attempt the installation yourself, but use a help of professional companies.

CAUTION: Fixtures may cause severe injuries when crashing down! If you have doubts concerning the safety of a possible installation, do not install the fixture!

The fixture has to be installed out of the reach of public.

The fixture must never be fixed swinging freely in the room.

Danger of fire!

When installing the device, make sure there is no highly inflammable material (decoration articles, etc.) in a distance of min. 0.5 m.

The special desing of the temperature filter has allowed to reduce distance between the fixture and lit objects, but the minimum distance of 5 meters between light output from the moving head and the lit objects must be kept!

Caution!

**Use 2 appropriate clamps to rig the fixture on the truss.
Follow the instructions mentioned at the bottom of the base.
Make sure that the device is fixed properly! Ensure that the structure (truss) to which you are attaching the fixtures is secure.**

The fixture can be placed directly on the stage floor or rigged in any orientation on a truss without altering its operation characteristics .

For securing a fixture to the truss, install a safety wire that can hold at least 10 times the weight of the fixture. Use only the safety wire with screw-on carabine. Pull the safety wire through the safety attachment point on the bottom of the base and around the truss as shown on the pictures below.

Truss installation via 2 Omega holders

Truss installation via mounting adapter

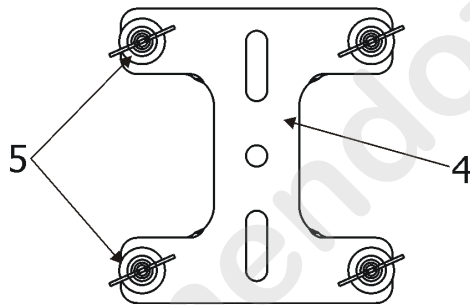
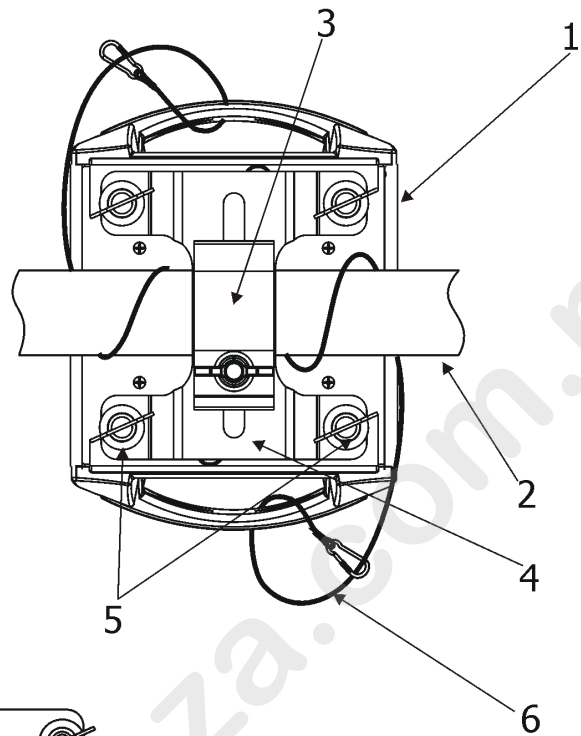
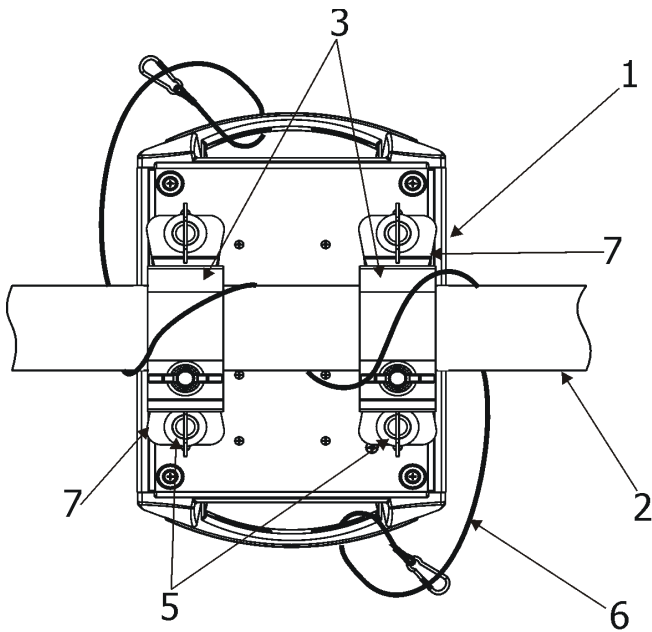

- 1-Fixture
- 2-Truss
- 3-Clamp
- 4-Mounting adapter
- 5-Quarter-turn fasteners
- 6-Safety wire
- 7-Omega holder

**When installing fixtures side-by-side,
avoid illuminating one fixture with another!**

DANGER TO LIFE!
Before taking into operation for the first time, the installation has to be approved by an expert!

3.5 DMX-512 connection

The fixture is equipped with 5-pin XLR sockets for DMX input and output.

Only use a shielded twisted-pair cable designed for RS-485 and 5-pin XLR-plugs and connectors in order to connect the controller with the fixture or one fixture with another.

DMX output

XLR socket:



- 1 - Shield
- 2 - Signal (-)
- 3 - Signal (+)
- 4 - Used for wireless DMX
- 5 - Used for wireless DMX

DMX input

XLR plug:

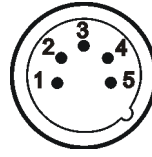

- 1 - Shield
- 2 - Signal (-)
- 3 - Signal (+)
- 4 - Used for wireless DMX
- 5 - Used for wireless DMX

If you are using the standard DMX controllers, you can connect the DMX output of the controller directly with the DMX input of the first fixture in the DMX-chain. If you wish to connect DMX-controllers with other XLR-outputs, you need to use adapter-cables.

Building a serial DMX-chain:

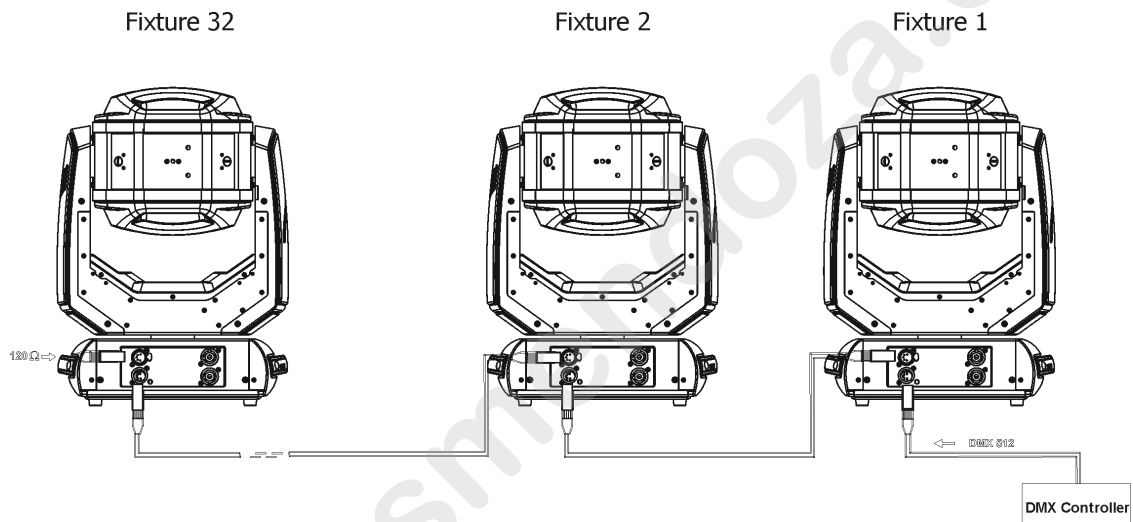

Connect the DMX-output of the first fixture in the DMX-chain with the DMX-input of the next fixture. Always connect one output with the input of the next fixture until all fixtures are connected.

Caution: At the last fixture, the DMX-cable has to be terminated with a terminator. Solder a 120 Ω resistor between Signal (-) and Signal (+) into a 5-pin XLR-plug and plug it in the DMX-output of the last fixture.

3.6 Wireless DMX operation

The wireless version of the Robin miniPointe is equipped with the Lumen Radio CRMX module and antenna for receiving DMX signal. CRMX module operates on the 2.4 GHz band.

Robe Wireless CRMX-LB100

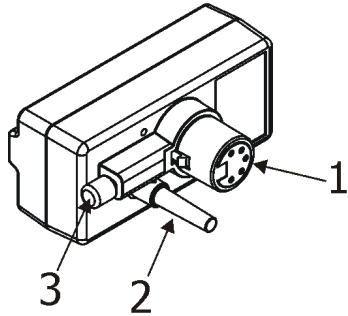

- 1 - 5-pin XLR (female)
- 2 - Locating pin
- 3 - Lock

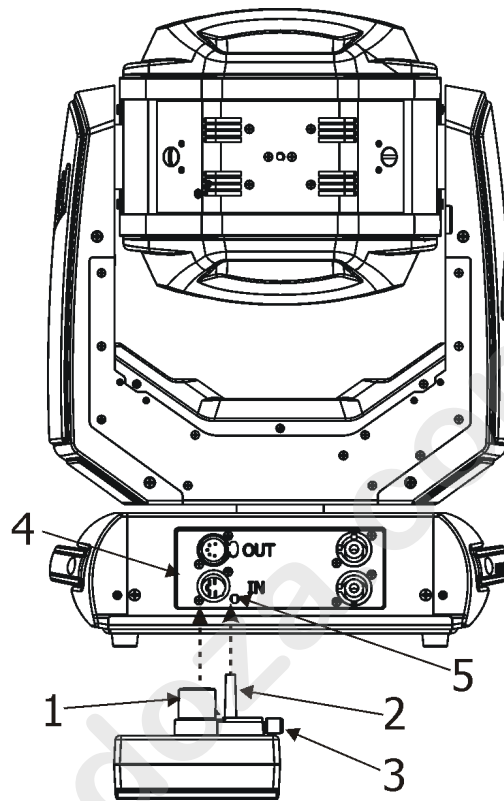

Push in the 5-pin XLR plug (1) into 5-pin XLR socket (4) and simultaneously locating pin (2) into hole (5) in the fixture. In this way the wireless DMX module is connected with the fixture.

NOTE: when you disconnect the DMX wireless module from fixture, press and hold lock (5) during getting the wireless module out.

To link the fixture with DMX transmitter.

The fixture can be only linked with the transmitter by running the link procedure at DMX transmitter .

After linking , the level of DMX signal (0-100 %) is displayed in the menu item "Stat" (Special -->Wireless -->Stat).

To unlink the fixture from DMX transmitter.

The fixture can be unlinked from receiver via the menu item " Unlink" (Special-->Wireless -->Unlink.).

3.7 Replacing colour filters

**Install colour filters with the device switched off only.
Unplug from mains before!**

Colour filters

1. Disconnect the fixture from mains and allow it to cool 20 minutes.
2. Remove the plastic cover of the head /from the side of the lamp driver (1)/ by loosening the 3 quarter-turn fasteners on the cover.
3. Turn the colour wheel (2) to the suitable position. The dichroic filters are fixed on the colour wheel by the magnets.
4. Release the dichroic filter (3) from the slot (5) of the colour wheel by inclining it from its position to break the power of the magnet (4). Protect the glass filter with a piece of paper or clout.
5. Insert a new dichroic filter into the colour wheel and check that it snapped into slot (5) correctly .
6. Place the plastic cover back before applying power.

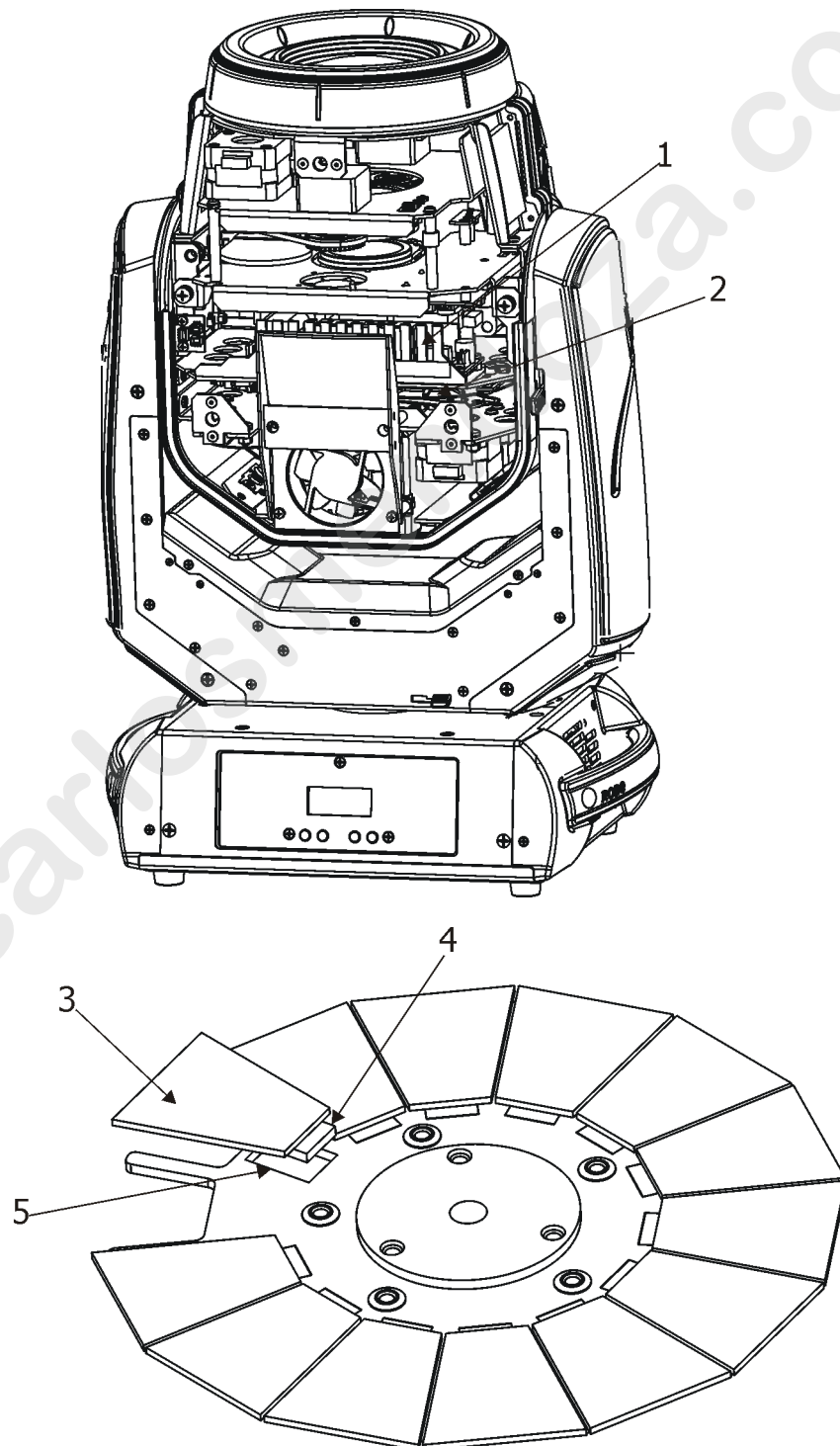

4. Remotely controllable functions

Lamp

The Robin miniPointe is to be operated with a OSRAM SIRIUS HRI 140W RO lamp. The OSRAM SIRIUS HRI 140W RO with its focusing dichroic reflector is highly efficient and optimized for wide range of light applications

Colour wheel

This wheel contains 13 replaceable dichroic filters + open. The colour wheel can be positioned between two adjacent colours in any position. It is also possible to rotate the colour wheel continuously at different speeds ("Rainbow effect" in both directions).

Static gobo wheel

The static gobo wheel includes 10 metal gobos and 3 beam reducers. Gobo positioning and gobo wheel rotation is available as well as a gobo-shake function.

Effects

Two rotating prisms: 14.6° and 16°.

Dynamic Flower Effect creates spectacular beam effects in the air which can change shape, size and speed of rotation.

Frost

Frost module provides variable frost for fine frosting.

Focus

Motorized focus allows to focus beam from approx. 4 metres to infinity.

Dimmer/Shutter unit

Smooth 0 - 100 % dimming is provided by the mechanical dimmer /shutter unit. This unit is also used for strobe effects with variable speed.

Pan/Tilt

Fast pan and tilt movement, pan movement range: 540°, tilt movement range 270°.

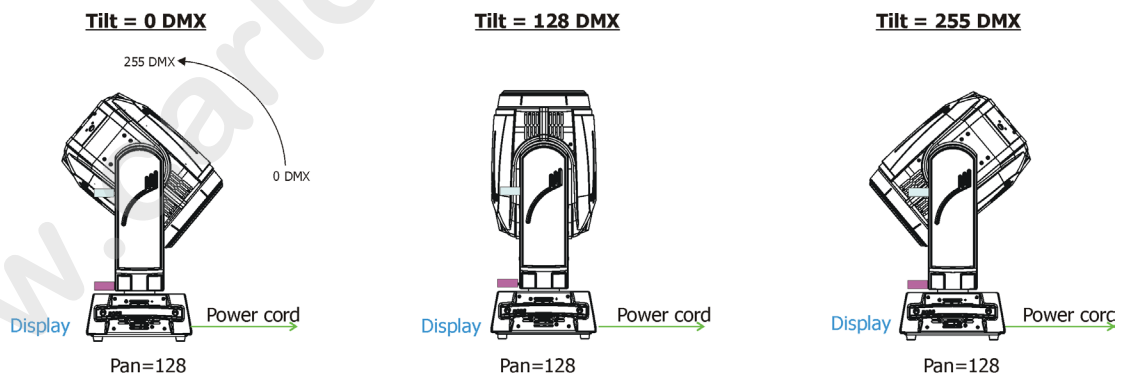

Tilt movement range: 270° Pan movement range: 540°

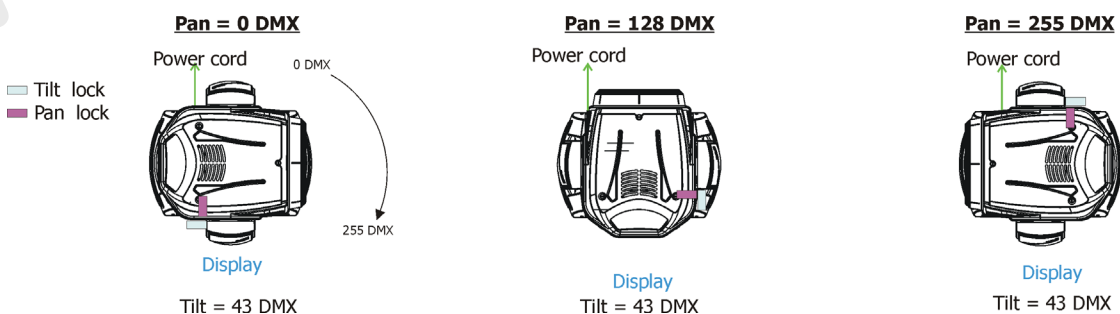

5. Control menu map

Default settings=**Bold print**

Level 1	Level 2	Level 3	Level 4	Level 5	Level 6	Level 7
DMXA	Set DMXA	001-255				
	DMX Pres	Mode 1				
		Mode 2				
		Mode 3				
Info	PO Time	Total				
		Reset				
	LA Time	Total				
		Reset				
	Air Fil	R Ti				
		Aler P	10-300			
	DMX In	Pan	0-255			
		:				
		Dim F	0-255			
	Hea Temp	Current				
		Highest				
		High Res				
	Bas Temp	Current				
		Highest				
		High Res				
	Sw Ver	IC-1				
		IC-2				
		IC-3				
		IC-4				
Pers	DMX Pres	Mode 1				
		Mode 2				
		Mode 3				
	Pan Rev	On, Off				
	Tilt Rev	On, Off				
	P/T Mode	Speed				
		Time				
	P/T Feed	On, Off				
	Lamp Pr	Lamp Au	On, Off			
		DMX Off	On, Off			
		DMX L On	On, Off			
		DMX L Of	On, Off			
		Lamp D	0-90			
	Lamp Sn	On, Off				
	Display	Turn				
		On/Off T	On, Off			
		Contrast	0-100%			
		Backlight	0-100%			
	BLC DMC	On, Off				
	Act BLC	P/T Mov	On, Off			
		CWh Mov	On, Off			
		StG Mov	On, Off			
	Mic Sens	0... 10 ...19				
	Fans	Auto, High				
	Temp Uni	°C, °F				

Level 1	Level 2	Level 3	Level 4	Level 5	Level 6	Level 7
	I Ef Pos	Pan				
		:				
		Dim F				
		Store				
	Defaults					
Lamp	On, Off					
Manual	Pan	0-255				
	:					
	Dim F	0-255				
Test Prg	Static	Pan	0-255			
		Tilt	0-255			
		Run				
	Dynamic					
Sta Alone	Music T	On, Off				
	Auti Run	Off				
		Test				
		Prog 1				
		Prog 2				
		Prog 3				
	Pr Play	Test Prg				
		Prog 1				
		Prog 2				
		Prog 3				
	Pr Edit	Prog 1	Step 1	Pan		
		Prog 2	:	:		
		Prog 3	Step 40	F.Tim	0-25.5	
				S.Tim	0-25.5	
				COPY		
				Prg End	1-40	
Reset						
Special	RDM Low					
	RDM Hight					
	Wireless	Stat				
		Unlink				
	Adjust	DMX Val	Pan	0-255		
			:			
			Dim F	0-255		
		Calib	Cal P/T	Pan C	0-255	
				Til C	0-255	
				Store		
			Cal Eff			
				Color	0-255	
				StGob		
				Eff1		
				E1Rot		
				Eff2		
				E2Rot		
				Focus		
				Fro1		
				Fro2		

Level 1	Level 2	Level 3	Level 4	Level 5	Level 6	Level 7
				S1-1		
				S1-2		
				S2-1		
				S2-2		
				Store		
	Sw Upd	On, Off				

www.carlosmendoza.com.mx

6. Control menu

The Robin miniPointe is equipped with 2-row LCD display which allows to set the fixture's behaviour according to your needs, obtain information on its operation, test its various parts and lastly program it, if it has to be used in a stand-alone mode.

Control panel:

[ESCAPE] button used to leave the menu without saving changes.

[NEXT] , [PREV] buttons for moving between menu items and for value adjusting.

[ENTER] button used to enter the selected menu and to confirm adjusted value.

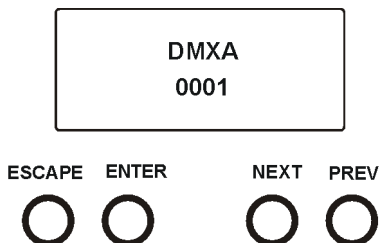

After switching the fixture on, display shows current DMX address.

6.1 Addressing (DMXA)

Set DMXA- Use this menu item to set the DMX start address of the fixture, which is defined as the first channel from which the Robin miniPointe will respond to the controller.

If you set, for example, the address 36, the Robin miniPointe will use channels 36 - 55 for control (if Mode 1 is selected).

Please, be sure that you do not have any overlapping channels in order to control each Robin miniPointe correctly and independently from any other fixture on the DMX data link.

If there is no data received at the DMX input, the display will start to flash "0001" with actually stored DMX address.

DMX Pres - DMX preset. Use the menu to select desired DMX channel mode.

Mode 1 - 22 control channels

Mode 2 - 17 control channels

Mode 3 - 27 control channels

6.2 Fixture information (Info)

PO Time - Power on time. Select this menu to read the number of the fixture operation hours.

Total - The item shows the total number of the operation hours since the Robin miniPointe has been fabricated.

Reset - The item shows the number of the operation hours that the Robin miniPointe has been powered on since the counter was last reset.

In order to reset this counter to 0, press and hold both [NEXT] and [PREV] buttons and the [Enter] button at the same time.

LA Time - Lamp on time. Select this menu to read the number of the lamp operation hours.

Total - The item shows the total number of the lamp operation hours since the Robin miniPointe has been fabricated.

Reset - The item shows the number of the lamp operation hours that the Robin miniPointe has been powered on since the counter was last reset.

In order to reset this counter to 0, press and hold both [NEXT] and [PREV] buttons and the [Enter] button at the same time.

Air Fil - Air filter. Regular cleaning of the air filter is very important for the fixture's life and performance.

Dust, dirt and fog fluid residues reduces the fixture's light output and cooling ability.

The two items of this menu help you to keep cleaning period of the air filter.

Alert P - Alert period. Cleaning schedule for the fixture depends on the operating environment.

It is therefore impossible to specify accurate cleaning interval. This item allows you to change the cleaning interval of the air filters. This "alert" value is 300 hours and it

is set as default. Inspect the fixture within its 300 hours of operation to see whether cleaning is necessary. If cleaning is required, clean all air filters and change the value in this menu on acceptable level. Min. level of alert period is 10 hours, max. is 300 hours.

R Ti - Remaining Time. The item allows you to read the time which remains to cleaning air filters. The time period is set in the menu mentioned above.

Expired time period is signalled by a negative mark (-) at the time value and a warning message on the display.

Clean the air filter and reset the counter by pressing the press and hold both [NEXT] and [PREV] buttons and the [Enter] button at the same time.

DMX In - DMX readout. The menu is used to read DMX values of each channel received by the fixture.

Hea Temp - Head temperature. The menu shows temperature of the fixture head.

Current - A current temperature in the fixture head.

Highest - A maximum temperature of the the fixture head since the fixture has been fabricated.

High Res - A maximum temperature of the the fixture head since the counter was last reset.

In order to reset this counter, press and hold both [NEXT] and [PREV] buttons and the [Enter] button at the same time.

Bas Temp - Base temperature. The menu shows temperature of the fixture base.

Current - A current temperature in the fixture base.

Highest - A maximum temperature of the the fixture base since the fixture has been fabricated.

High Res - A maximum temperature of the the fixture base since the counter was last reset.

In order to reset this counter, press and hold both [NEXT] and [PREV] buttons and the [Enter] button at the same time.

Sw Ver - Software versions. Select this item to read the software version of the fixture modules.

IC-1 - A pan/Tilt processor

IC-2 - EEPROM

IC-3 - A Color wheel/static gobo wheel/shutter/focus processor

IC-4 - A Prism/frost processor

6.3 Personality (Pers)

DMX Pres - DMX preset. Use the menu to select desired channel mode.

Mode 1 - 20 control channels

Mode 2 - 15 control channels

Mode 3 - 25 control channels

Pan Rev - Pan reverse. The item allows to invert pan movement.

Tilt Rev - Tilt reverse. The item allows to invert tilt movement.

P/T Mode - Pan and Tilt movement mode. Use this menu to set mode of the pan/tilt movement.

Speed - Both Pan and tilt will move with the same speed as adjusted at the channel 5 "Pan/Tilt speed, Pan/Tilt time".

Time - The pan and tilt will move with different speeds and they will come at the same time to the end point of their tracks (pan and tilt use their optimal speeds).

Time of the pan/tilt movement (25.5 sec. max.) is set by the channel "Pan/Tilt speed, Pan/Tilt time".

P/T Feed - Pan and Tilt Feedback. The menu item allows to return the moving head to the required pan/tilt position after changing the position by an external force if this option is set on.

Note. The Pan/Tilt Feedback should be permanent On, the option Off is not suitable for standard operation and the head of the fixture can be damaged!

Lamp Pr - Lamp preset. Use this menu to set behaviour of the fixture lamp.

Lamp Au - If the item is On, the lamp will be automatically turn on after switching the fixture on.

DMX Off - The item enables to switch the lamp off via DMX command from DMX controller. In this case, the item has to be On.

DMX L On - The item allows you to strike the lamp automatically after 26 seconds if DMX signal is present on the fixture's DMX input.

Lamp Off if not DMX - The item allows you to switch off the lamp automatically after 2 minutes if DMX signal is missing on the fixture's DMX input.

Lamp D - The item allows to set time delay(0-90sec.) before igniting the lamp by DMX command. If the lamp is started directly from the control panel, the set time delay will be ignored.

Lamp Sn - Select this item to switch the light sensor off. The option On is intended for a standard operation.

Display - Display adjusting. This menu allows you to adjust the display behaviour.

Turn - This function turns the display by 180°.

On/Off T - This function allows you to keep the display permanent on or turn it off two minutes after last pressing any button on the control panel.

Contrast- Use this function to adjust contrast of the display (0-100%).

Backlight- Use this function to adjust backlight of the display (0-100%).

BLC DMC - Blackout during movement correction. Set this option on if you wish to close light output during the time when the head goes to its correct position, which has been changed by an external force.

Act Blc - Active blackout. Use this menu if you wish to close the light output during effect changes.

P/T Mov - The menu item allows to close light output while the pan (tilt) position is changing.

GWh Mov - The menu item allows to close light output while colours are changing.

StG Mov - The menu item allows to close light output while gobos are changing.

Mic Sens - Microfon sensitivity. Enter the menu if you want to adjust the microphone sensitivity (1-max., 19-min.).

Fans - Fan mode. Use the menu to set the fixture fans to max. fan power mode ("**High**") or to auto-control mode ("**Auto**").

Temp Uni - Temperature unit. Use the menu item to change temperature unit from °C to °F.

I Ef Pos - Init effect positions. Use the menu to set all effects to the desired positions at which they will stay after switching the fixture on without DMX signal connected.

Defaults - The menu item allows to set all fixture parameters to the default (factory) values.

6.4 Lamp on/off (Lamp)

On - Lamp on. Use the menu item to switch the lamp on.

Off - Lamp off. Use the menu item to switch the lamp off.

6.5 Manual Control (Manual)

Manual C - Manual control. Use the menu to control all fixture channels by means of the control panel.

Pan - a pan movement

Pan F - a fine pan movement

Tilt - a tilt movement

Tilt F - a fine tilt movement

P/T S a pan/tilt speed

Powr - power/special functions

ColWh - a colour wheel movement

ColWh F a fine colour wheel movement

Frost T - a frost time

Color T - a colour wheel time

STGob T - a static gobo wheel time
Pri T - an prism 14.6°/prism 16° time
Focus T - a focus time
StGobWh - a static gobo wheel movement
P 14.6 - a prism 14.6°
P 14.6 R - a prism 14.6° rotation and indexing
P 16 - a prism 16°
P 16 R - a prism 16° rotation and indexing
DFE - a dynamic flower effects
DFE R - a DFE rotation
Beam S - a beam shaper
Frost - a frost
Focus a focus movement
Focus F a fine focus movement
Stro - a shutter/strobo
Dimm - a dimmer
Dim F - a dimmer (fine)

6.6 Test program (Test Prg)

Use this menu to to run a special demo sequences without an external controller, which will show you some possibilities of using the Robin miniPointe.

Static - Static mode. This mode is suitable for projections on the wall, ceiling or ground without any head movement.

Dynamic - Dynamic mode. This mode uses all Robin miniPointe functions including pan/tilt movement and therefore is good for a complete introduction of the fixture.

6.7 Stand-alone (St Alone)

Music T - Music trigger. Select this function to enable the sound control of the running program via the built-in microphone.

Auto Run - Presetting playback. This function allows you to select the program which will be played in the stand-alone mode after switching the fixture on. Selected program will be played continuously in a loop.

Off - The option disables „Auto Run” function.

Test - The option will start built-in test program.

Prog 1 - The option will start user-created program 1

Prog 2 - The option will start user-created program 2

Prog 3 - The option will start user-created program 3

Pr Play - Playing program. Select this menu to run a user-created program in a loop.

Test Prg - The option runs built-in test program.

Prog 1 - The option runs user-created program 1

Prog 2 - The option runs user-created program 2

Prog 3 - The option runs user-created program 3

Select the program you wish and press [ENTER]. The selected program starts running. By Pressing [ENTER] again, program pauses running.

Pr Edit - Editing program. Select this menu to edit or create the program. The Robin miniPointe has one built-in program and one user-editable program up to 40 steps. Each program step has a step time - during which effects last in the current step and a fade time- during which effects move to new positions.

To edit program:

Procedure:

1. Press [NEXT] or [PREV] to select the menu "Edit" and press [ENTER].
2. Press [NEXT] or [PREV] to select the desired program step and press [ENTER] button.
3. Press [NEXT] or [PREV] to select the desired item and press [ENTER] button. Now you can edit by [NEXT] or [PREV] buttons the DMX value (0-255) for selected item:

Prg End. a total number of the program steps (value 1-40). This value you should be set before starting of programming (e.g. if you want to create program with the 10 steps, set Prg End=10).

Pan - a pan movement

Pan F - a fine pan movement

Tilt - a tilt movement

Tilt F - a fine tilt movement
 P/T S a pan/tilt speed
 Powr - power/special functions
 ColWh - a colour wheel movement
 ColWh F a fine colour wheel movement
 Frost T - a frost time
 Color T - a colour wheel time
 STGob T - a static gobo wheel time
 Pri T - an prism 14.6°/prism 16° time
 Focus T - a focus time
 StGobWh - a static gobo wheel movement
 P 14.6 - a prism 14.6°
 P 14.6 R - a prism 14.6° rotation and indexing
 P 16 - a prism 16°
 P 16 R - a prism 16° rotation and indexing
 DFE - a dynamic flower effects
 DFE R - a DFE rotation
 Beam S - a beam shaper
 Frost - a frost
 Focus a focus movement
 Focus F a fine focus movement
 Stro - a shutter/strobo
 Dimm - a dimmer
 Dim F - a dimmer (fine)
 F.Tim a fade time (0-25.5 sec)
 S.Tim a step time (0-25.5 sec)
 COPY copying the current prog. step to the next prog. step

4. Press [ENTER] button to confirm adjusted value .

5. Press [ESCAPE] button, select next prog. step, press [ENTER] button and repeat steps 3 - 5).

6.8 Reset (Reset)

This option allows to index all effects and return to their standard positions.

6.9 Special functions (Special)

RDM Low - This menu item shows the first part of the RDM identification code.

RDM High - This menu item shows the second part of the RDM identification code.

Wireless - Wireless DMX information. The menu allows to read some information about Wireless DMX operation

Stat - Wireless status. Use the menu to read wireless DMX status.

Unlink - use this item to unlink fixture from wireless DMX.

Adjust - Adjustment. The menu allows the fine adjustment of effects.

DMX Val- DMX values. Use the menu to set DMX values of fixture's channels.

Calib - calibration of fixture effects.

Cal P/T - Use this menu to calibrate pan/tilt position.

Pan C - a fine pane movement

Tilt C - a fine tilt movement

Store - saving adjusted values

Cal Eff - Use this menu to calibrate effects:

Colour - a fine movement of the colour wheel

StGob - a fine static gobo movement

P 14.6 - a fine prism 14.6° movement

P 14.6 R - a fine prism 14.6° rotation

P 16 - a fine prism 16° movement

P 16 R - a fine prism 16 rotation

Focus - a fine focus movement

Fro1 - a frost position 1

Fro2 - a frost position 2
 S1-1 - a strobe lamella 1 position 1
 S1-2 - a strobe lamella 1 position 2
 S2-1 - a strobe lamella 2 position 1
 S2-2 - a strobe lamella 2 position 2
 Store - saving adjusted values

Cal Load - Loads default (factory) calibration.

Calibration of the pan/tilt via the control board

1. Disconnect DMX controller from the fixture and enter the "Cal P/T" menu.
2. Use the [PREV] and [NEXT] to find "Pan" and press [ENTER].
3. Set desired value and save it by pressing [ENTER].
4. Repeat steps 2 and 3 for Tilt.
5. After calibrating both effects, find item "Store" and press [ENTER] to save all adjusted values and reset the fixture.

Calibration of effects via the control board

1. Disconnect DMX controller from the fixture and enter the "Cal Eff" menu.
2. Use the [PREV] and [NEXT] to find desired effect and press [ENTER].
3. Set value and save it by pressing [ENTER].
4. Repeat steps 2 and 3 for another effect.
5. After calibrating desired effects, find item "Store" and press [ENTER] to save all adjusted values and reset the fixture.

Note: you can also use DMX controller for both calibrations stated above, calibration protocol is the following:

Effect	Mode 1	Mode 2	Mode 3
Pan	channel 23	channel 17	channel 28
Tilt	channel 24	channel 18	channel 29
Colour wheel	channel 25	channel 19	channel 30
Static Gobo	channel 26	channel 20	channel 31
Prism 14.6°	channel 27	channel 21	channel 32
Prism 14.6° Rotation	channel 28	channel 22	channel 33
Prism 16°	channel 29	channel 23	channel 34
Prism 16° Rotation	channel 30	channel 24	channel 35
Focus	channel 31	channel 25	channel 36
Frost position 1	channel 32	channel 26	channel 37
Frost position 2	channel 33	channel 27	channel 38
Strobe lamella 1 pos. 1	channel 34	channel 28	channel 39
Strobe lamella 1 pos. 2	channel 35	channel 29	channel 40
Strobe lamella 2 pos. 1	channel 36	channel 30	channel 41
Strobe lamella 2 pos. 2	channel 37	channel 31	channel 42

Sw Upd - The menu item allows you to update software in the fixture via the Robe Universal Interface.

The following are required in order to update software:

- PC running Windows 95/98/2000/XP/7/8 or Linux
- Software Uploader
- Robe Universal Interface or Flash cable RS232/DMX (S.N.13050624)

Note: Software update should execute a qualified person. If you lack qualification, do not attempt the update yourself and ask for help your ROBE distributor.

DMX address, programs 1-3 and all items in the menu "Personality" will be set to their default (factory) values.

To update software in the fixture:

I. Installation of the Robin miniPointe Software Uploader.

1. The Robin miniPointe Software Uploader program is available from the ROBE web site at WWW.robe.cz.
2. Make a new directory (e.g. Robe_Uploader) on your hard disk and download the software to it.
3. Unpack the Software Uploader.

II. Fixture software updating.

1. Connect DMX output of the Robe Universal Interface with the fixture. Connect USB input of

the Robe Universal Interface with your PC (or, if you use the Flash cable, use it to connect serial port of your PC with the DMX input of the fixture)

Disconnect the fixture from the other fixtures in a DMX chain. Turn both the computer and the fixture on. Make sure the fixture's lamp is switched off.

2. Switch the fixture to the updating mode (menu "Sw Upd").

Note: If you do not want to continue in software update, you have to switch off and on the fixture to escape from this menu.

We recommend to cancel all running programs before starting the Software Uploader.

3. Run the Software Uploader program.

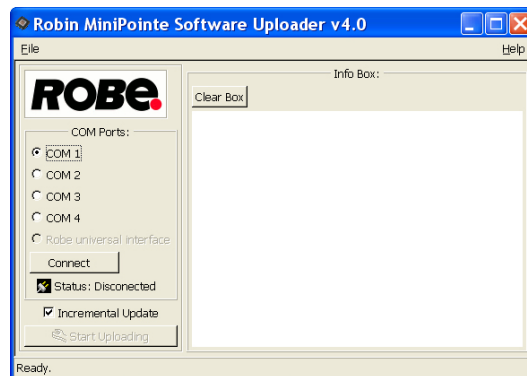

Select Robe universal Interface (or suitable com, if you use the Flash cable) on the left side of the software uploader screen and then click on the Connect button.

If the connection is OK, click on the "Start Uploading" button to start uploading. It may take several minutes to perform software update.

If the option "Incremental Update" is not checked, all processors will be updated (including processors with the same software version).

If you wish to update only later versions of processors, check the "Incremental Update box".

Avoid interrupting the process. Update status is being displayed in the Info Box window.

When the update is finished, the line with the text "The fixture is successfully updated" will appear in this window and the fixture will reset with the new software.

Note: In the case of an interruption of the upload process (e.g. power cut), the fixture keeps the updating mode and you have to repeat the software update again.

7. RDM

This fixture supports RDM operation. RDM (Remote Device Management) is a bi-directional communications protocol for use in DMX512 control systems, it is the new open standard for DMX512 device configuration and status monitoring.

The RDM protocol allows data packets to be inserted into a DMX512 data stream without adversely affecting existing non-RDM equipment. By using a special „Start Code,“ and by complying with the timing specifications for DMX512, the RDM protocol allows a console or dedicated RDM controller to send commands to and receive messages from specific moving lights.

RDM allows explicit commands to be sent to a device and responses to be received from it.

The list of commands for Robin miniPointe is the following.

Parameter ID	Discovery command	SET command	GET command
DISC_UNIQUE_BRANCH	*		
DISC_MUTE	*		
DISC_UN_MUTE	*		
DEVICE_INFO			*
SUPPORTED_PARAMETERS			*
SOFTWARE_VERSION_LABEL			*
DMX_START_ADDRESS		*	*
IDENTIFY_DEVICE		*	*
DEVICE_MODEL_DESCRIPTION			*
MANUFACTURER_LABEL			*

DEVICE_LABEL		*	*
SENSOR_DEFINITION			*
SENSOR_VALUE			*
DISPLAY_INVERT		*	*
DISPLAY_LEVEL		*	*
PAN_INVERT		*	*
TILT_INVERT		*	*
DEVICE_RESET		*	
DMX_PERSONALITY		*	*
DMX_PERSONALITY_DESCRIPTION			*
STATUS_MESSAGES			*
STATUS_ID_DESCRIPTION			*
LAMP_STATE		*	*
LAMP_ON_MODE ¹		*	*
DEVICE_HOURS ²			*
LAMP_HOURS ²			*
LAMP_STRIKES ²			*

¹...Another options for this command (only for Robe´s fixtures):

value PARAMETER_DATA=0x84 - lamp OFF by DMX value on DMX channel
value PARAMETER_DATA=0x88 - lamp OFF if DMX is not present

²...Commands relative resetable values

8. Error and information messages

Lamp Err (Lamp Error)

If the ignition of the lamp is 4 times unsuccessful , the display shows “LampErr”, meaning that the lamp could be damaged or even missed or there could be a failure on the lamp driver.

Ovh Err (Overheated)

This message informs that the fixture had been overheated and the lamp was switched off by means of the head temperature sensor.

Temp Err (Temper. Sensor Error)

The message informs you that the communication between the head temperature sensor and the main processor failed and the lamp has been switched off.

Tilt Err (Tilt Error)

This message will appear after the reset of the fixture if the tilt sensor sensor failed or magnet is missing or the stepping motor is defective or its driving IC on the PCB. The head is not located in the default position after the reset.

Pan Err (Pan Error)

This message will appear after the reset of the fixture if the pan sensor failed or magnet is missing or the stepping motor is defective or its driving IC on the PCB. The yoke is not located in the default position after the reset of the fixture.

CWh Err (Colour Wheel Error)

The messages will appear after the reset of the colour wheel if this wheel is not located in the default position.

StG Err (Static Gobo Wheel Error)

The messages will appear after the reset of the static gobo wheel if this wheel is not located in the default position.

P14.6 Err (Prism 14.6° Error)

The messages will appear after the reset of the prism 14.6° if this prism is not located in the default position.

P14.6R Err (Prism 14,6° Rotation Error)

The messages will appear after the reset of the prism 14.6° if this prism is not located in the default position.

P16 Err (Prism 16 Error)

The messages will appear after the reset of the prism 16 if this prism is not located in the default position.

P16R Err (Prism 16° Rotation Error)

The messages will appear after the reset of the prism 16° if this prism is not located in the default position.

AirFi Err (Air Filters Error)

This message informs you that the menu item remaining time ("R Ti ") in the menu "Information" is at 0 value. Clean air filters in the fixture head and reset this counter.

Fan1 Err

The turbine which cools a top of the lamp is faulty. The lamp has been switched off.

Fan2 Err

The fan above lamp in the fixture head is faulty. The lamp has been switched off.

Fan3 Err

The fan above lamp in the fixture head is faulty. The lamp has been switched off.

Fan4 Err

The small fan in front of the lamp driver is faulty. The lamp has been switched off.

Location of fans:

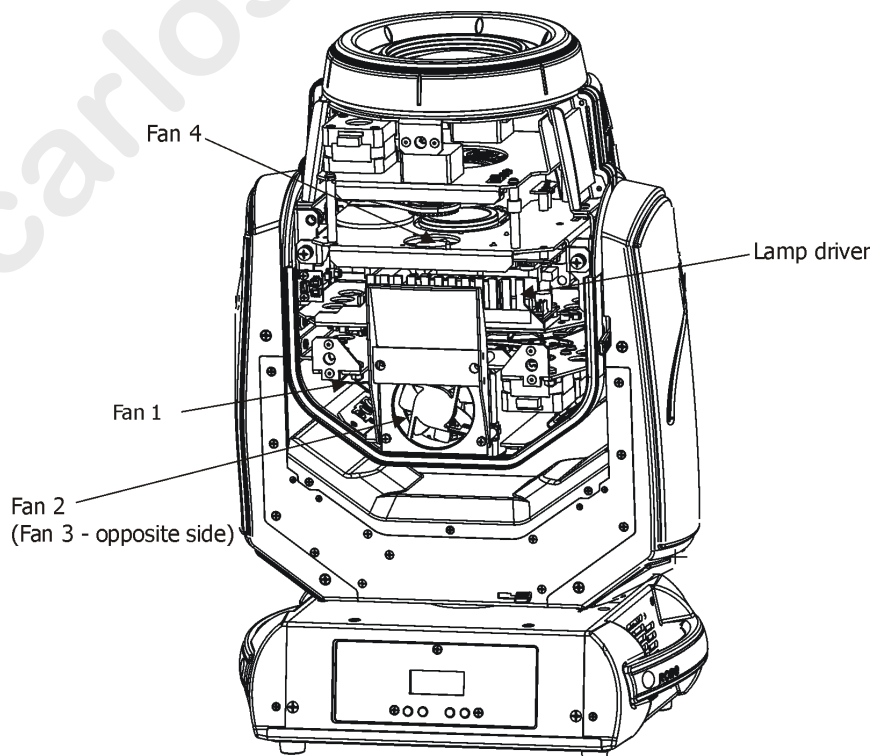

9. Technical Specifications

Electrical

Power supply:.....electronic auto-ranging
Input voltage range:..... supply 100-240V, 50/60Hz
Power consumption*:.....260 W at 230V (I=1,15A,power factor 0.97)
Mains input: 16A max. (CE), 10A max. (cETLus)
Mains output: 15A max. (CE), 9A max. (cETLus)
*Allow for a deviation of +/-5%

Lamp

Approved model: OSRAM SIRIUS HRI 140W RO
Average service life: 6000 hrs

Ballast

Electronic

Beam angles

open/hole: 3°
beam reducer 1: 0.7°
beam reducer 2: 1.2°
beam reducer 3: 1.8°
(frost inserted): 12° @ 1/10 beam
Prism 14.6°
Prism 16°

Colour wheel

13 replaceable dichroic filters + white

Static gobo wheel

10 metal gobos & 3 beam reducers

Effects

Two rotating indexable prisms (14,6° and 16°)
Dynamic Flower Effect - creating spectacular beam effects which can change shape, size and speed of rotation

Frost filter

Separate,variable frost filter

Strobe

Strobe effect with variable speed (max.15 flashes/sec.)

Dimmer

Smooth dimmer from 0 - 100 %

Control

2-row LCD display & 4 buttons
Readout fixture and lamp usage, receiving DMX values, temperatures, etc
Built-in analyzer for easy fault finding, error messages
Remotely switching on/off the lamp
Built-in demo sequences
Black-out while head moving, colour or gobo changing
Stand-alone operation
3 user editable programs, each up to 40 steps
Supported protocols: USITT DMX 512, RDM
3 DMX modes (22,17, 27 control channels)

External Wireless DMX/RDM module (option)

Compliance with USITT DMX-512 (1986 & 1990) and 512-A
Full DMX fidelity and frame integrity
Auto sensing of DMX frame rate and frame size
<5ms DMX latency
Operational frequency range of 2402-2480 MHz
Producer: LumenRadio

Pan/Tilt

Pan movement range 540°
Tilt movement range 270°
16 bit movement resolution
Automatic Pan/Tilt position correction
Remotely controllable speed of pan/tilt movement for easy programming
Movement control: tracking and vector
Pan/tilt lock mechanism

Connection

DMX in/Out: 5-pin XLR
AC power input: Chassis connector Neutrik PowerCon, A-type, NAC3MPA
AC power output: Chassis connector Neutrik PowerCon, B-type, NAC3MPB

Rigging

Mounting points: 2 pairs of 1/4-turn locks
Mounting horizontally or vertically via 2 Omega brackets

Temperatures

Maximum ambient temperature: 45°C (for CE)
25°C (for cETLus)
Maximum housing temperature : 75° C

Minimum distances

Min. distance from flammable surfaces: 0.5 m
Min. distance to lit objects: 5 m

Total heat dissipation

780 BTU/h (calculated)
228 Wh (calculated)

Weight (net):

11.8 kg

Dimensions (mm)

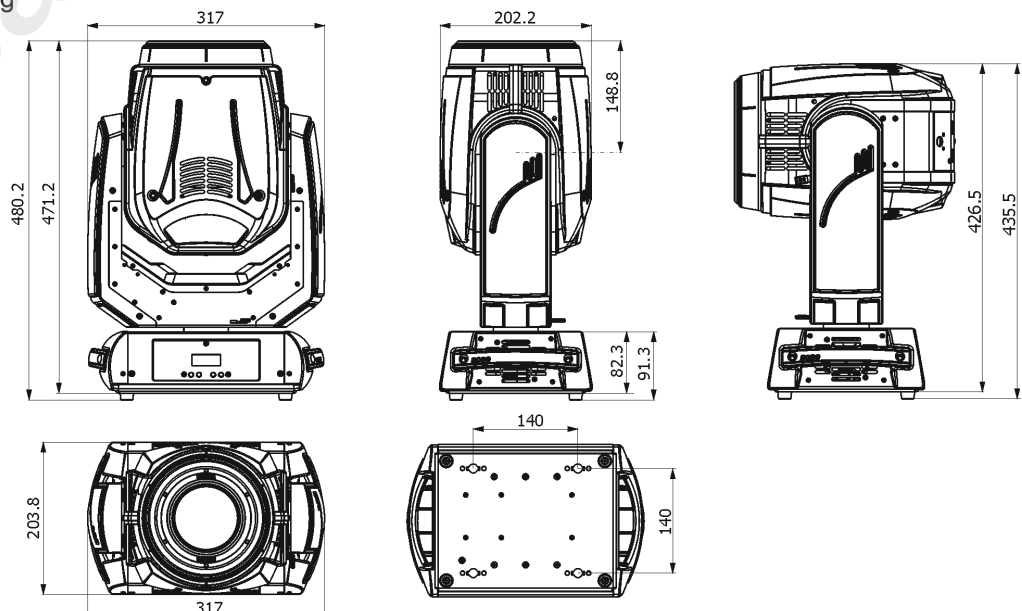

Accessories

Omega holder (S.N.99010420).....2 pcs

Optional Accessories

- Mounting adapter (S/N.99013318)
- Flash cable RS232/DMX (S/N.13050624)
- (P/N1305 1731) Mains Cable PowerCon In/open ended, 2m
- (P/N 1305 1724) Mains Cable PowerCon In/Schuko, 2m
- (P/N 1305 1725) Mains Cable PowerCon In/CEE 16A, 2m
- (P/N 1305 1726) Mains Cable PowerCon In/US, 2m
- (P/N 1305 1727) Daisy Chain PowerCon In/Out, EU, 2m
- (P/N 1305 1728) Daisy Chain PowerCon In/Out, US, 2m
- (P/N/ 10980127) ROBE Wireless CRMX

Photometric diagram

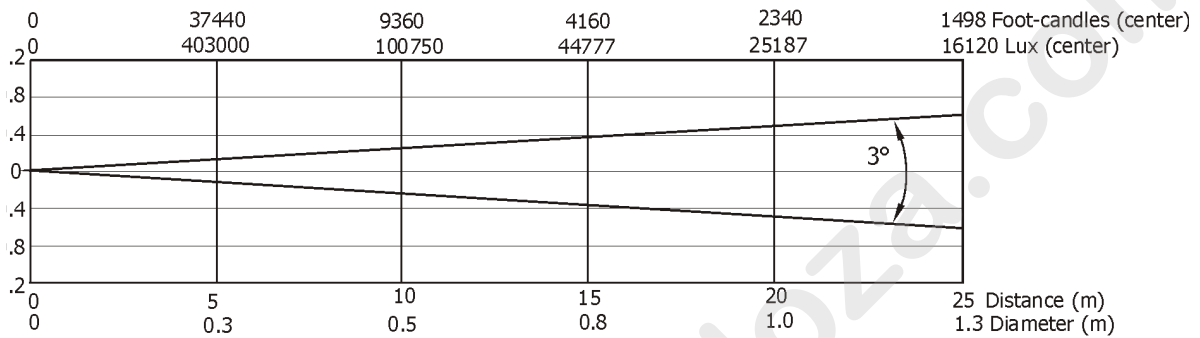

Open/Hole with frost

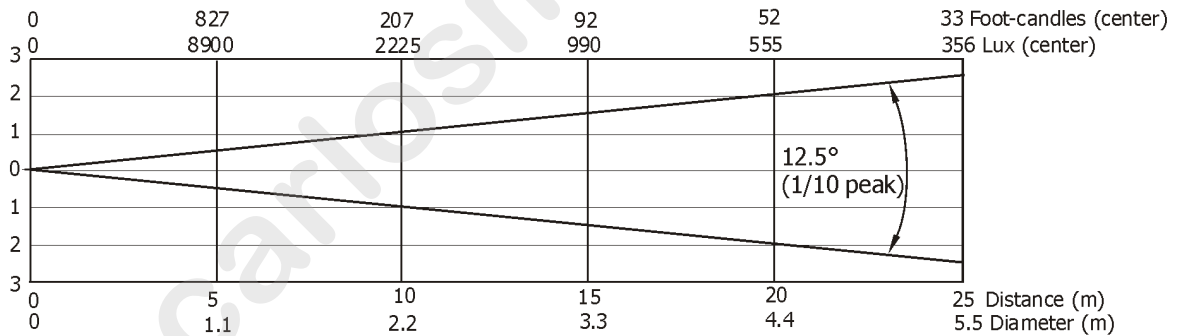

Illuminance distribution

Distance=5m

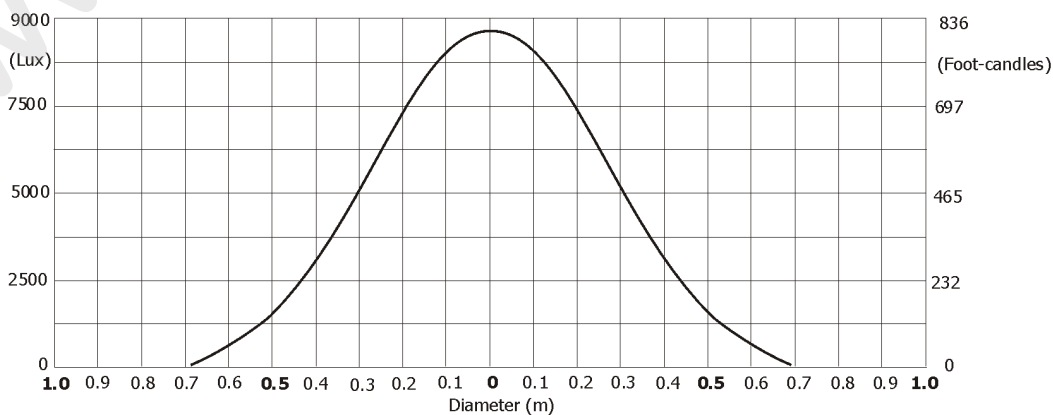

10. Maintenance and cleaning

It is absolutely essential that the fixture is kept clean and that dust, dirt and smoke-fluid residues must not build up on or within the fixture. Otherwise, the fixture's light-output will be significantly reduced. Regular cleaning will not only ensure the maximum light-output, but will also allow the fixture to function reliably throughout its life. A soft lint-free cloth moistened with any good glass cleaning fluid is recommended, under no circumstances should alcohol or solvents be used!

DANGER !

Always disconnect the fixture from the mains before starting any maintenance work

If the fixture is connected to mains, high voltage is present at the heat sink of the lamp driver and at some parts of this lamp driver in the fixture head !

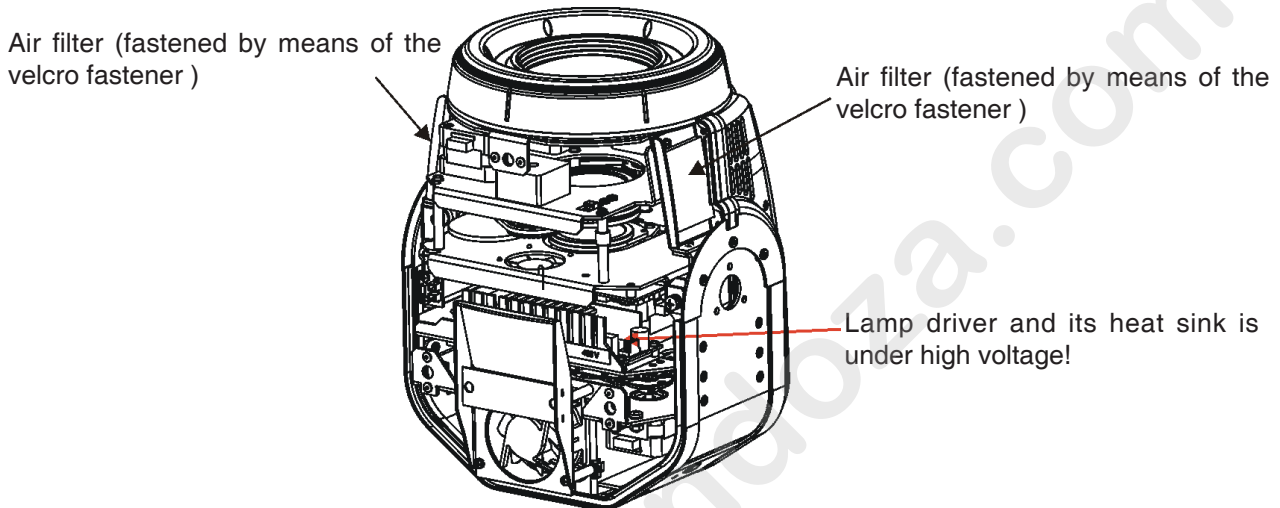

The front objective lens will require weekly cleaning as smoke-fluid tends to building up residues, reducing the light output very quickly. The cooling fans should be cleaned monthly. The interior of the fixture should be cleaned at least annually using a vacuum-cleaner or an air-jet. Dichroic colour filters and gobo wheel and the internal lenses should be cleaned monthly. Remove dust and dirt from the fans and cooling vents using a soft brush and vacuum-cleaner.

More complicated maintenance and service operations are only to be carried out by authorized distributors.

Important! Check the air filters in the fixture head periodically and clean before they become clogged!

Clean the air filters placed in the fixture head. Use a vacuum cleaner, compressed air or you can wash them and put back dry.

After replacing the air filters, reset the elapsed time counter in the menu "Information" (Info--->Air Fil--->Ela T).

11. ChangeLog

This section summarizes all types of changes in the user manual.

Version of the manual	Date of issue	Description of changes
1.1	11/01/2015	Added items "LA Time" , "Hea Temp" and "Bas Temp" into menu Info.
1.2	13/09/2016	Added (P/N/ 10980127) ROBE Wireless CRMX to Optional Accessories

September 13, 2016

Copyright © 2014-2016 Robe Lighting - All rights reserved

All Specifications subject to change without notice

DMX protocol

Robin MiniPointe - DMX protocol, version 1.0						
Mode/channel			DMX Value	Function	Type of control	
Mode 1 Standard 16 bit	Mode 2 Reduced 8 bit	Mode 3 Extended 16 bit				
1	1	1		Pan		
			0 - 255	Pan movement by 540°	proportional	
2	*	2		Pan Fine		
			0 - 255	Fine control of pan movement	proportional	
3	2	3		Tilt		
			0 - 255	Tilt movement by 270°	proportional	
4	*	4		Tilt fine		
			0 - 255	Fine control of tilt movement	proportional	
5	3	5		Pan/Tilt speed , Pan/Tilt time		
			0	Standard mode	step	
			1	Max. Speed Mode	step	
				Pan/Tilt speed mode		
			2 - 255	Speed from max. to min.	proportional	
				Pan/Tilt time mode		
			2 - 255	Time from 0.2 s to 25.5 sec.	proportional	
6	4	6		Power/Special functions		
			0 - 49	Reserved		
				<i>To activate following functions, stop in DMX value for at least 3 s and shutter must be closed at least 3 sec. („Shutter,Strobe” channel 20/16/25 must be at range: 0-31 DMX). Corresponding menu items are temporarily overridden except DMX Input.</i>		
			50 - 59	Pan/Tilt speed mode	step	
			60 - 69	Pan/Tilt time mode	step	
			70 - 79	Blackout while pan/tilt moving	step	
			80 - 89	Disabled blackout while pan/tilt moving	step	
			90 - 99	Blackout while colour wheel moving	step	
			100 - 109	Disabled blackout while colour wheel moving	step	
			110 - 119	Blackout while gobo wheel moving	step	
			120-129	Disabled blackout while gobo wheel moving	step	
				<i>To activate following functions, stop in DMX value for at least 3 seconds:</i>		
			130 - 139	Lamp On	step	
			140 - 149	Pan/Tilt reset	step	
			150 - 159	Colour wheel reset	step	
			160 - 169	Static gobo wheel reset	step	
			170 - 179	Dimmer/Shutter	step	
			180 - 189	Focus/Prisms reset	step	
			190 - 199	Reserved	step	
			200 - 209	Total reset	step	
			210 - 229	Reserved		
			230 - 239	Lamp Off	step	
			240 - 255	Reserved		
7	5	7		Colour wheel		
				Continual positioning		

DMX protocol

Mode/channel			DMX Value	Function	Type of control
Mode 1 Standard 16 bit	Mode 2 Reduced 8 bit	Mode 3 Extended 16 bit			
			0	Open/white	proportional
			9	Deep Red	proportional
			18	Deep Blue	proportional
			27	Yellow	proportional
			37	Light green	proportional
			46	Magenta	proportional
			55	Lavender	proportional
			64	Pink	proportional
			73	Dark green	proportional
			82	CTO 2700K	proportional
			91	Blue	proportional
			101	Orange	proportional
			110	CTO 3200K	proportional
			119	UV (Kongo blue)	proportional
			128-129	White	step
				Positioning	
			130-134	Deep Red	step
			135-138	Deep Blue	step
			139-143	Yellow	step
			144-147	Light green	step
			148-152	Magenta	step
			153-157	Lavender	step
			158-161	Pink	step
			162-166	Dark green	step
			167-171	CTO 2700K	step
			172-176	Blue	step
			177-180	Orange	step
			181-185	CTO 3200K	step
			186-189	UV (Kongo blue)	step
			190 - 215	Forwards rainbow effect from fast to slow	proportional
			216 - 217	No rotation	step
			218 - 243	Backwards rainbow effect from slow to fast	proportional
			244 - 249	Random colour selection by audio control (Set microphone sensitivity in menu „Personality“)	step
			250 - 255	Auto random colour selection from fast to slow	proportional
8	*	8		Colour wheel - fine positioning	
			0 - 255	Fine positioning	proportional
*	*	9		Frost time	
			0	Function is off	step
			1 - 255	Time of frost movement (0.1 sec. --- >25.5 sec.)	proportional
*	*	10		Color time	
			0	Function is off	step
			1 - 255	Time of colour wheel movement (0.1 sec. --- >25.5 sec.)	proportional
*	*	11		Static gobo time	
			0	Function is off	step
			1 - 255	Time of static gobo wheel movement (0.1 sec. --- >25.5 sec.)	proportional

DMX protocol

Mode/channel			DMX Value	Function	Type of control
Mode 1 Standard 16 bit	Mode 2 Reduced 8 bit	Mode 3 Extended 16 bit			
*	*	12		Prism 14.6° and Prism 16° time	
			0	Function is off	step
			1-50	Time of prism movement (0.1 sec. --- > 5 sec.)	proportional
			1 - 255	Time of prism rotation (0.1 sec. --- >25.5 sec.)	proportional
*	*	13		Focus time	
			0	Function is off	step
			1 - 255	Time of focus movement (0.1 sec. --- >25.5 sec.)	proportional
9	6	14		Static gobo wheel	
			0-3	Open/hole	step
				<u>Positioning</u>	
			4-9	Gobo 1	step
			10-15	Gobo 2	step
			16-21	Gobo 3	step
			22-27	Gobo 4	step
			28-33	Gobo 5	step
			34-39	Gobo 6	step
			40-45	Gobo 7	step
			46-51	Gobo 8	step
			52-57	Gobo 9	step
			58-63	Gobo 10	step
			64-69	Beam reducer 1	step
			70-75	Beam reducer 2	step
			76-81	Beam reducer 3	step
			82-87	Open/hole	step
				<u>Shaking gobos from slow to fast</u>	
			88-95	Gobo 1	proportional
			96-103	Gobo 2	proportional
			104-111	Gobo 3	proportional
			112-119	Gobo 4	proportional
			120-127	Gobo 5	proportional
			128-135	Gobo 6	proportional
			136-143	Gobo 7	proportional
			144-151	Gobo 8	proportional
			152-159	Gobo 9	proportional
			160-167	Gobo 10	proportional
			168-175	Beam reducer 1	proportional
			176-183	Beam reducer 2	proportional
			184-191	Beam reducer 3	proportional
			192-201	Open/hole	step
			202 - 221	Forwards gobo wheel rotation from fast to slow	proportional
			222 - 223	No rotation	
			224 - 243	Backwards gobo wheel rotation from slow to fast	proportional
			244 - 249	Random gobo selection by audio control	step
				(Set microphone sensitivity in menu „Personality“)	
			250 - 255	Auto random gobo selection from fast to slow	proportional
10	7	15		Prism 14.6°	
			0 - 19	Open position (hole)	step

DMX protocol

Mode/channel			DMX Value	Function	Type of control
Mode 1 Standard 16 bit	Mode 2 Reduced 8 bit	Mode 3 Extended 16 bit			
			20 -127	Prism indexing	step
			128 - 255	Prism rotation	step
11	8	16		Prism 14.6° rotation and indexing	
				<i>Prism indexing - set position on channel 10/7/15</i>	
			0 - 255	Prism indexing	proportional
				<i>Prism rotation - set position on channel 10/7/15</i>	
			0	No rotation	step
			1 - 127	Forwards rotation from fast to slow	proportional
			128	No rotation - <u>default</u>	step
			129-255	Backwards rotation from slow to fast	proportional
12	9	17		Prism 16°	
			0 - 19	Open position (hole)	step
			20 -127	Prism indexing	step
			128 - 255	Prism rotation	step
13	10	18		Prism 16° rotation and indexing	
				<i>Prism indexing - set position on channel 12/9/17</i>	
			0 - 255	Prism indexing	proportional
				<i>Prism rotation - set position on channel 12/9/17</i>	
			0	No rotation	step
			1 - 127	Forwards rotation from fast to slow	proportional
			128	No rotation - <u>default</u>	step
			129-255	Backwards rotation from slow to fast	proportional
14	11	19		DFE - Shape/Effect selection	
				<i>Static Shapes Index - set indexing on channel 15/12/20</i>	
			0-7	No function	step
			8-11	Shape 1	step
			12-15	Shape 2	step
			16-19	Shape 3	step
			20-23	Shape 4	step
			24-27	Shape 5	step
			28-31	Shape 6	step
			32-35	Shape 7	step
			36-39	Shape 8	step
			40-43	Shape 9	step
			44-47	Shape 10	step
			48-51	Shape 11	step
				<i>Static Shapes rotation - set rotation on channel 15/12/20</i>	
			52-55	Shape 1	step
			56-59	Shape 2	step
			60-63	Shape 3	step
			64-67	Shape 4	step
			68-71	Shape 5	step
			72-75	Shape 6	step
			76-79	Shape 7	step
			80-83	Shape 8	step
			84-87	Shape 9	step
			88-91	Shape 10	step

DMX protocol

Mode/channel			DMX Value	Function	Type of control
Mode 1 Standard 16 bit	Mode 2 Reduced 8 bit	Mode 3 Extended 16 bit			
			92-95	Shape 11 <i>Dynamic flower effects</i>	step
			96-99	Effect 1	step
			100-103	Effect 2	step
			104-107	Effect 3	step
			108-111	Effect 4	step
			112-115	Effect 5	step
			116-119	Effect 6	step
			120-123	Effect 7	step
			124-127	Effect 8	step
			128-131	Effect 9	step
			132-255	Reserved	
15	12	20		DFE & Beam shaper Indexing and rotation control	
				<i>DFE indexing - set position on channel 14/11/19</i>	
				<i>Beam shaper indexing - set position on channel 16/13/21</i>	
			0 - 255	DFE indexing	proportional
				<i>DFE rotation - set position on channel 10/7/15</i>	
				<i>Beam shaper rotation - set position on channel 16/13/21</i>	
			0	No rotation	step
			1 - 127	Forwards rotation from fast to slow	proportional
			128	No rotation - <u>default</u>	step
			129-255	Backwards rotation from slow to fast	proportional
16	13	21		Beam shaper selection*	
				<i>Static Shapers Index - set indexing on channel 15/12/20</i>	
			0-7	No function	step
			8-11	Shaper 1	step
			12-15	Shaper 2	step
			16-19	Shaper 3	step
			20-23	Shaper 4	step
			24-27	Shaper 5	step
			28-31	Shaper 6	step
			32-35	Shaper 7	step
			36-39	Shaper 8	step
			40-43	Shaper 9	step
			44-47	Shaper 10	step
			48-51	Shaper 11	step
				<i>Static Shapers rotation - set rotation on channel 15/12/20</i>	
			52-55	Shaper 1	step
			56-59	Shaper 2	step
			60-63	Shaper 3	step
			64-67	Shaper 4	step
			68-71	Shaper 5	step
			72-75	Shaper 6	step
			76-79	Shaper 7	step
			80-83	Shaper 8	step
			84-87	Shaper 9	step
			88-91	Shaper 10	step

DMX protocol

Mode/channel			DMX Value	Function	Type of control
Mode 1 Standard 16 bit	Mode 2 Reduced 8 bit	Mode 3 Extended 16 bit			
			92-95	Shaper 11 <i>Dynamic shapers</i>	step
			96-99	Effect 1	step
			100-103	Effect 2	step
			104-107	Effect 3	step
			108-111	Effect 4	step
			112-115	Effect 5	step
			116-119	Effect 6	step
			120-123	Effect 7	step
			124-127	Effect 8	step
			128-131	Effect 9	step
			132-255	Reserved * Static gobo wheel and frost is blocked If DMX value > 7	
17	14	22		Frost	
			0	Open	step
			1 - 179	Frost from 0% to 100%	proportional
			180 - 189	100% frost	step
			190 - 211	Pulse closing from slow to fast	proportional
			212 - 233	Pulse opening from fast to slow	proportional
			234 - 255	Ramping from fast to slow	proportional
18	15	23		Focus	
			0 - 255	Continuous adjustment from far to near	proportional
19	*	24		Focus - fine	
			0- 255	Fine focusing	proportional
20	16	25		Shutter/ strobe	
			0 - 31	Shutter closed	step
			32 - 63	Shutter open	step
			64 - 95	Strobe-effect from slow to fast	proportional
			96 - 127	Shutter open	step
			128 - 143	Opening pulse in sequences from slow to fast	proportional
			144 - 159	Closing pulse in sequences from fast to slow	proportional
			160 - 191	Shutter open	step
			192 - 223	Random strobe-effect from slow to fast	proportional
			224 - 255	Shutter open	step
21	17	26		Dimmer intensity	
			0 - 255	Dimmer intensity from 0% to 100%	proportional
22	*	27		Dimmer intensity - fine	
			0 - 255	Fine dimming	proportional
Note: the Beam Shaper channel has priority to the DFE-Shape/Effect selection channel and both channels have priority to Prisms channels					
Copyright © 2014-2016 Robe Lighting s.r.o. - All rights reserved					
All Specifications subject to change without notice					

